

RP415F4

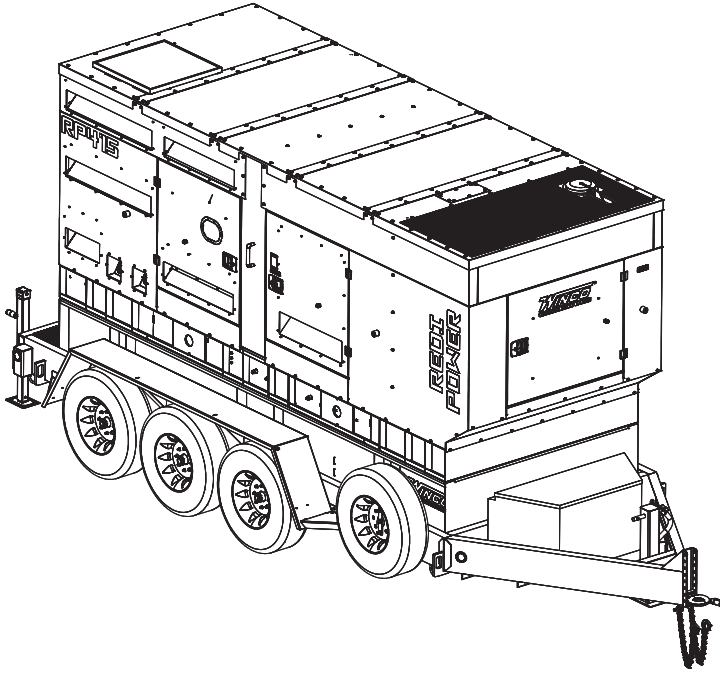

Designed, engineered, and manufactured in our facility located in Le Center, Minnesota, equipped with modern engineering, fabrication and assembly capabilities.

Switchable Voltage Option

Easily switch from single phase to three phase.

Oil Field Skid

Ready to work with its rugged design.

Cam-Lock Receptacles

Quickly connect loads without hard wiring.



		STANDBY			PRIME				
		VOLTS	POWER FACTOR	WATTS	KVA	AMPS	WATTS	KVA	AMPS
SWITCHABLE	120/208 3-PH	0.8	370,000	462	1,284	333,000	416	1,156	
	277/480 3-PH	0.8	370,000	462	556	333,000	416	500	

DEDICATED VOLTAGE AVAILABLE

MOTOR STARTING (CODE G)	260 HP
DBA @ 7 METERS FULL LOAD	-
TOTAL HARMONIC DISTORTION	< 5%
MAIN CIRCUIT BREAKER	1200A, 600V (SHUNT)
BONDED NEUTRAL	YES
120 VOLT RECEPTACLES	(2) NEMA 5-20 20A (GFCI)
120/240 VOLT RECEPTACLES	(2) C6369 50A
REQUIRED BATTERIES ⁽¹⁾	(2) GROUP 4D 1050 CCA

BATTERY CHARGER	5 AMP SOLAR
FORKLIFT POCKETS	STANDARD
ASSEMBLED IN	USA
EPA APPROVED	TIER IV FINAL
CARB APPROVED	TIER IV FINAL
TÜV CSA CERTIFICATION	YES
UNIT WARRANTY ⁽²⁾	1 YEAR/2,000 HOURS

ENGINE

ENGINE BRAND	FPT
ENGINE MODEL	C13ENTZW69
RATING	TIER IV FINAL
ENGINE STARTER	24V ELECTRIC
ENGINE SPEED	1800 RPM
ENGINE CYLINDERS	6
ENGINE HP	568
FREQUENCY	60 HZ
ALTERNATOR	120 AMPS
FLYWHEEL	14"
ROTATION	CCW
ASPIRATION/COOLING	TURBOCHARGED
COOLANT	12.7 GAL
BORE/STROKE	135mm x 150mm
DISPLACEMENT/TYPE	12.8 L

LOW OIL PROTECTION	STANDARD
RECOMMENDED OIL ⁽³⁾	5W-40 SAE
OIL CAPACITY	8.5 GAL
INJECTION PUMP	BOSCH
GOVERNOR	ELECTRONIC
COMPRESSION RATIO	16.5:1
FAN TYPE	PUSHER
INTAKE AIR CONSUMPTION	1,014 CFM
RADIATOR COOLING AIR	N/A
EXHAUST	1,029 CFM
EXHAUST OUTLET SIZE	8"
STARTING AIDES	PTC 24V GRID HEATER
STARTING TEMP NATURAL W/ AIDES	14° F
STARTING TEMP W/BLOCK HEATER	-13° F

FUEL

TYPE	ASTM D975 NO-2D DIESEL
FUEL TANK	500 GAL 110% CONTAINMENT
FULL LOAD RUN TIME ⁽⁴⁾	20.5 HOURS
DEF TANK CAPACITY	135 L

DEF CONSUMPTION	-
FUEL CONSUMPTION	GAL/HR
100%	24.4
75%	19.6
50%	13.7
25%	7.6

GENERATOR END

GENERATOR END BRAND	STAMFORD
GENERATOR END MODEL	S4L1D-G4
WINDING	
208/240/480V	311 - 12 LEAD
600V	17 - LEAD
VOLTAGE REGULATION	AVR +/- 1%
AVR TYPE	MX321 PMG
TEMPERATURE RISE	125/40°C
TYPE	REVOLVING FIELD
BRUSHLESS	YES

SPEED	1800 RPM
ROTOR	2/3 PITCH
WINDINGS	100% COPPER
STATOR WINDING	DOUBLE LAYER CONCENTRIC
COUPLING	DIRECT/FLEXIBLE DISC
BEARINGS	SINGLE (MAINTENANCE FREE)
EFFICIENCY PEAK	93.6
INSULATION	CLASS H
INGRESS PROTECTION	IP23

DERATES

ABOVE SEA LEVEL	
3,280-9,842 FT	3% EVERY 1,640 FT
> 9,842 FT	6% EVERY 1,640 FT

AMBIENT TEMPERATURE	
>104°F	2% EVERY 9°F

BLOCK HEATER

VOLTS	120
WATTS	2,500
AMPS	20 AMPS

THERMOSTAT	
ON	80° F
OFF	100° F



TRAILER

CAPACITY	18,000 LBS
TORFLEX AXLES	TRIPLE
STANDARD HITCH SIZE	3" PINTLE

HITCH HEIGHT	ADJUSTABLE
TIRES	15"
TIRE PRESSURE	65 PSI

DSE 7310 MKII CONTROLLER

ENGINE DISPLAY/PROTECTION	
ENGINE RPM	YES
LOW OIL PRESSURE	YES
HIGH COOLANT TEMP	YES
LOW COOLANT	YES
OVER/UNDER SPEED	YES
OVER CRANK	YES
CAN ECU SHUTDOWN	YES
GENSET DISPLAY/PROTECTION	
VOLTAGE (L-N & L-L)	YES
OVER/UNDER VOLTAGE	YES
FREQUENCY	YES
OVER/UNDER FREQUENCY	YES
AMP DISPLAY/SHUTDOWN	YES
PHASE IMBALANCE	DISABLED
KW, KVA, KVARH DISPLAY	YES
KWH, KVAH, KVARH DISPLAY	YES
GENERATOR PHASE SEQUENCE	OPTIONAL

ADDITIONAL DISPLAYS/PROTECTIONS	
EXTERNAL E-STOP	YES
BATTERY VOLTAGE	YES
BATTERY OVER/UNDER VOLTAGE	YES
COMMUNICATIONS	
USB CONNECTABLE	YES
RS232/RS485	YES
NFPA ANNUNCIATOR	OPTIONAL
REMOTE DISPLAY PANEL	OPTIONAL
ETHERNET/MODEM	OPTIONAL
ADDITIONAL FEATURES	
AUDIBLE ALARM	YES
ENGINE EXERCISER	YES
MAINTENANCE INTERVAL TIMER	OPTIONAL
LOAD SHEDDING/DUMMY	OPTIONAL
CONFIGURABLE INPUTS	4 (EXPANDABLE)
CONFIGURABLE OUTPUTS	4 (EXPANDABLE)
EVENT LOG	250

SHIPPING

SHIPPING DIMENSIONS (L x W x H)	270" x 110" x 120"
SHIP WEIGHT	15,020 LBS
FREIGHT CLASS	85

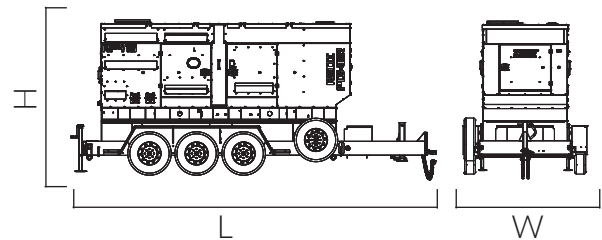

OPTIONAL ACCESSORIES

50 AMP PLUG	CS6365C
TRAILER ACCESSORIES	SPARE TIRE TOOL BOX

BATTERY	GROUP 24 650 CCA
DSE8610	WITH PARALLELING CONTACTOR

NOTES:

- (1) Batteries are not included.
 - (2) For more warranty information, see operator's manual.
 - (3) The recommended oil is for normal applications.
See operator's manual for more oil recommendations.
 - (4) Run time is estimated.
- Specifications are subject to change without notice.
Specifications are subject to change without notice.



Sales: 507-357-6821
Service: 507-357-6831

