

RP130F4

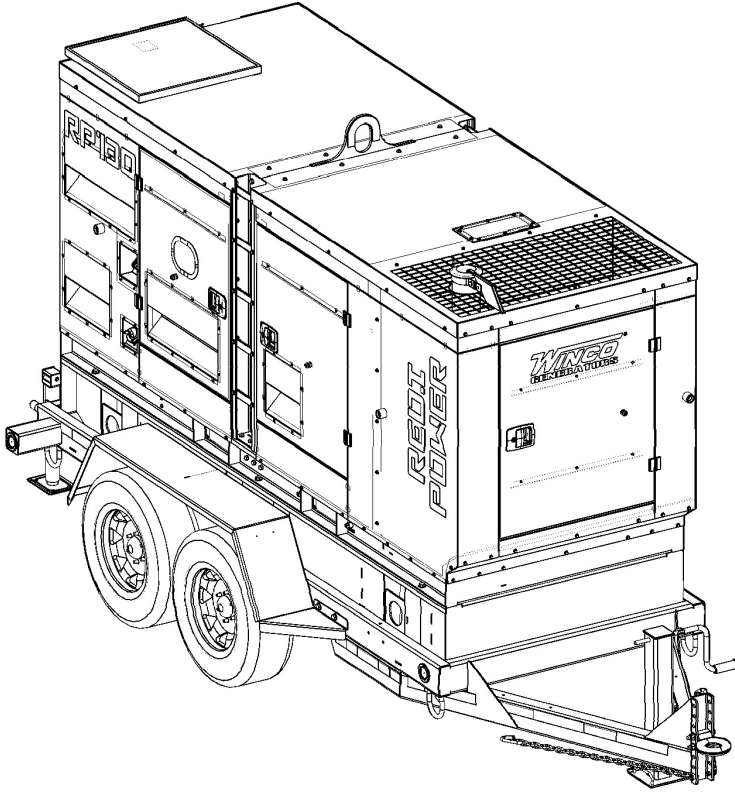

Designed, engineered, and manufactured in our facility located in Le Center, Minnesota, equipped with modern engineering, fabrication and assembly capabilities.

Switchable Voltage Option

Easily switch from single phase to three phase.

Oil Field Skid

Ready to work with its rugged design.

Cam-Lock Receptacles

Quickly connect loads without hard wiring.

Loading Features

The engine is outfitted with a variable speed fan and an electronic exhaust flap actuator. These features load the engine and keep the operating temperatures in optimal ranges over a wide variety of ambient temperatures and local conditions.



	VOLTS	POWER FACTOR	STANDBY			PRIME		
			WATTS	KVA	AMPS	WATTS	KVA	AMPS
SWITCHABLE	120/240 1-PH	1.0	110,000	110,000	458	100,000	100,000	416
	120/208 3-PH	0.8	110,000	137,000	381	100,000	125,000	347
	277/480 3-PH	0.8	110,000	137,000	165	100,000	125,000	150
DEDICATED	120/240 3-PH	0.8	110,000	137,000	330	100,000	125,000	300
	346/600 3-PH	0.8	110,000	137,000	132	100,000	125,000	120

MOTOR STARTING (CODE G)	50 HP
DBA @ 7 METERS FULL LOAD	72
TOTAL HARMONIC DISTORTION	< 5%
MAIN CIRCUIT BREAKER	400A, 600V (SHUNT)
BONDED NEUTRAL	YES
120 VOLT RECEPTACLES	(2) NEMA 5-20 20A (GFCI)
120/240 VOLT RECEPTACLES	(2) C6369 50A
REQUIRED BATTERY ⁽¹⁾	2 QTY GROUP 24 650 CCA

BATTERY CHARGERS	8 AMP GUEST SOLAR W/ CONTROLLER
FORKLIFT POCKETS	STANDARD
ASSEMBLED IN	USA
EPA APPROVED	TIER V FINAL
CARB APPROVED	TIER IV FINAL
TÜV CSA CERTIFICATION	YES
UNIT WARRANTY ⁽²⁾	1 YEAR/2,000 HOURS

ENGINE

ENGINE BRAND	FPT
ENGINE MODEL	N45ENTZW69
RATING	TIER IV FINAL
ENGINE STARTER	24V DC
ENGINE SPEED	1800 RPM
ENGINE CYLINDERS	4
ENGINE HP	168
FREQUENCY	60 HZ
ALTERNATOR	70 AMPS 12V
FLYWHEEL	11.5"
ROTATION	CCW
ASPIRATION/COOLING	TURBOCHARGED
COOLANT	7.4 GAL
BORE/STROKE	10 mm x 132 mm
DISPLACEMENT/TYPE	4.5 L

LOW OIL PROTECTION	STANDARD
RECOMMENDED OIL ⁽³⁾	5W-40 SAE
OIL CAPACITY	3.7 GAL
INJECTION PUMP	ELECTRONIC COMMON RAIL
GOVERNOR	ELECTRONIC
COMPRESSION RATIO	17:1
FAN TYPE	PUSHER - VISCOUS CLUTCH
INTAKE AIR CONSUMPTION	- CFM
RADIATOR COOLING AIR	1980 CFM
EXHAUST FLOW	320 CFM
EXHAUST OUTLET SIZE	5"
STARTING AIDES	PTC 24V GRID HEATER
STARTING TEMP NATURAL W/ AIDES	-4°
STARTING TEMP W/BLOCK HEATER	-22° F
BATTERY CHARGER	5 AMP + SOLAR

FUEL

TYPE	ASTM D975 NO-2D DIESEL
FUEL TANK	200 GAL - 110% CONTAINMENT
FULL LOAD RUN TIME ⁽⁴⁾	28 HOURS

FUEL CONSUMPTION	GAL/HR
100%	7.1
75%	5.9
50%	3.9
25%	2.5
DEF TANK CAPACITY	65 L

GENERATOR END

GENERATOR END BRAND	STAMFORD
GENERATOR END MODEL	UCI274F
WINDING	
3-PHASE	311 - 12 LEAD
600V	17 - 6 LEAD
VOLTAGE REGULATION	AVR +/- 1%
AVR TYPE	AS440
TEMPERATURE RISE	125/40°C
TYPE	REVOLVING FIELD
BRUSHLESS	YES

SPEED	1800 RPM
ROTOR	2/3 PITCH
WINDINGS	100% COPPER
STATOR WINDING	DOUBLE LAYER CONCENTRIC
COUPLING	DIRECT/FLEXIBLE DISC
BEARINGS	SINGLE (MAINTENANCE FREE)
EFFICIENCY PEAK	92.7% 3-PH
INSULATION	CLASS H
INGRESS PROTECTION	IP23

DERATES

ABOVE SEA LEVEL	
3280-9842 FT	3% EVERY 1,640 FT
> 9,842 FT	6% EVERY 1,640 FT

AMBIENT TEMPERATURE >104°F	2% EVERY 9°F
----------------------------	--------------

BLOCK HEATER

VOLTS	120
WATTS	1,500
AMPS	12.5 AMPS

THERMOSTAT	
ON	100° F
OFF	120° F



TRAILER

CAPACITY	10,000 LBS
TORFLEX AXLES	TANDEM
STANDARD HITCH SIZE	2 5/16"

HITCH HEIGHT	ADJUSTABLE
TIRES	14"
TIRE PRESSURE	50 PSI

DSE 7310 MKII CONTROLLER

ENGINE DISPLAY/PROTECTION	
ENGINE RPM	YES
LOW OIL PRESSURE	YES
HIGH COOLANT TEMP	YES
LOW COOLANT	YES
OVER/UNDER SPEED	YES
OVER CRANK	YES
CAN ECU SHUTDOWN	YES
GENSET DISPLAY/PROTECTION	
VOLTAGE (L-N & L-L)	YES
OVER/UNDER VOLTAGE	YES
FREQUENCY	YES
OVER/UNDER FREQUENCY	YES
AMP DISPLAY/SHUTDOWN	YES
PHASE IMBALANCE	DISABLED
KW, KVA, KVARH DISPLAY	YES
KWH, KVAH, KVARH DISPLAY	YES
GENERATOR PHASE SEQUENCE	OPTIONAL

ADDITIONAL DISPLAYS/PROTECTIONS	
EXTERNAL E-STOP	YES
BATTERY VOLTAGE	YES
BATTERY OVER/UNDER VOLTAGE	YES
COMMUNICATIONS	
USB CONNECTABLE	YES
RS232/RS485	YES
NFPA ANNUNCIATOR	OPTIONAL
REMOTE DISPLAY PANEL	OPTIONAL
ETHERNET/MODEM	OPTIONAL
ADDITIONAL FEATURES	
AUDIBLE ALARM	YES
ENGINE EXERCISER	YES
MAINTENANCE INTERVAL TIMER	OPTIONAL
LOAD SHEDDING/DUMMY	OPTIONAL
CONFIGURABLE INPUTS	4 (EXPANDABLE)
CONFIGURABLE OUTPUTS	4 (EXPANDABLE)
EVENT LOG	250

SHIPPING

SHIPPING DIMENSIONS (L x W x H)	199" x 80" x 100"
SHIP WEIGHT	7,300 LBS
FREIGHT CLASS	85

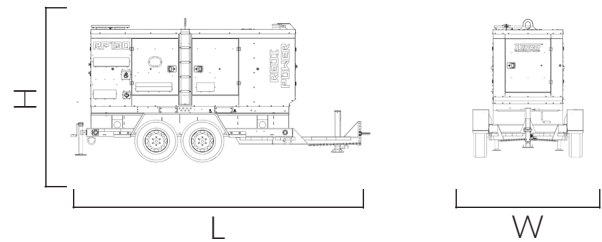

OPTIONAL ACCESSORIES

COUPLER	3" PINTLE
50 AMP PLUG	CS6365C
TRAILER ACCESSORIES	SPARE TIRE TOOL BOX

BATTERY	2 - GROUP 24 650 CCA
DSE8610	WITH PARALLELING CONTACTOR

- NOTES:
- (1) Batteries not included.
 - (2) For more warranty information, see operator's manual.
 - (3) The recommended oil is for normal applications. See operator's manual for more oil recommendations.
 - (4) Run time is estimated.
- Specifications are subject to change without notice.



Sales: 507-357-6821
Service: 507-357-6831

