

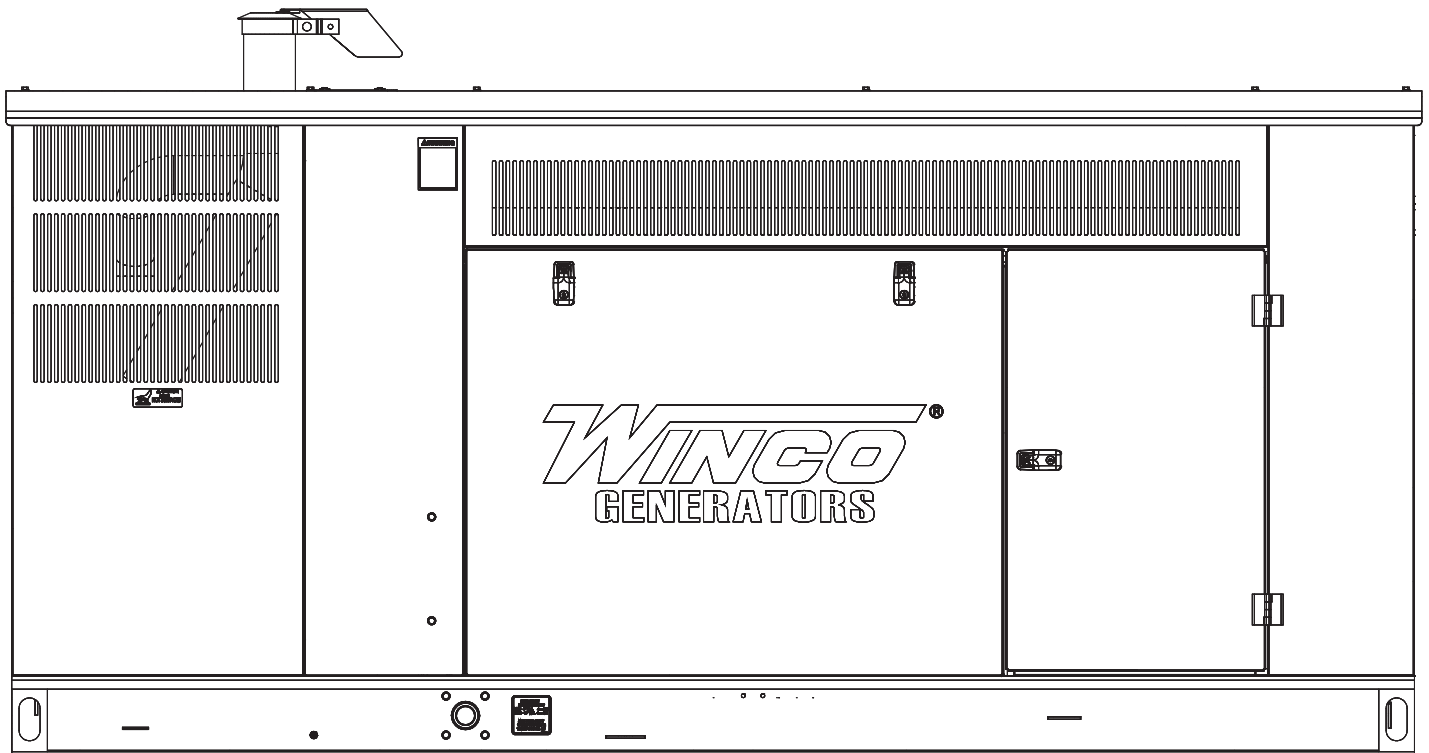

PSS65F4-XX/2  
PSS65F4-XX/3

# INSTALLATION & OPERATORS MANUAL



COPY YOUR MODEL AND SERIAL NUMBER HERE  
No other WINCO generator has the same serial number as yours.  
If you should ever need to contact us on this unit, it will help us to respond to your needs faster.

MODEL \_\_\_\_\_

SERIAL NUMBER \_\_\_\_\_

PURCHASE DATE \_\_\_\_\_

DEALER NAME \_\_\_\_\_

DEALER PHONE # \_\_\_\_\_



# TABLE OF CONTENTS

SAVE THESE INSTRUCTIONS	2	TROUBLESHOOTING TABLES	23
SAFETY INFORMATION	3	AC WIRING	24
SPECIFICATIONS	4	DSE 7310 MKII WIRING DIAGRAM	25
PSS65F4		LIMITED WARRANTY	26
INTRODUCTION	5		
TESTING POLICY			
PRODUCT DESCRIPTION			
PREPARING THE UNIT	6		
START-UP CHECK LIST			
UNPACKING			
LIFTING THE GENERATOR SET			
INSTALLATION	7		
GENERAL INFORMATION			
ENGINE-GENERATOR SET MOUNTING			
VENTILATION REQUIREMENTS			
EXHAUST INSTALLATION			
FUEL INSTALLATION			
INSTALLING THE FUEL LINE			
LIQUID PROPANE VAPOR (LP)			
NATURAL GAS (NG)			
FUEL PRESSURE			
FUEL PRESSURE TABLES			
NG/LP FUEL CONVERSION			
ELECTRICAL CONNECTIONS	11		
AC ELECTRICAL CONNECTIONS			
GROUNDING			
DC ELECTRICAL CONNECTIONS			
DC INTERCONNECTIONS TO ATS			
TRANSFER SWITCH			
MOUNTING THE ATS			
INSTALLING THE BATTERY	14		
SERVICING BATTERIES			
BATTERY CHARGING			
BATTERY CHARGER & BLOCK HEATER			
STARTING PROCEDURE	16		
LUBRICATION			
COOLANT			
PRE-START CHECK LIST			
CONTROL LAYOUT	17		
MANUAL MODE			
AUTO MODE			
CONTROL POWER			
VOLTAGE REGULATOR	19		
OPERATING CONDITIONS	19		
NORMAL OPERATION			
HARSH ENVIRONMENTS OPERATIONS			
COLD WEATHER OPERATIONS			
MAINTENANCE	20		
CHANGING THE OIL			
CHANGING OIL FILTER			
FILLING COOLANT			
CHANGING COOLANT			
COOLANT FILL & BURP INSTRUCTIONS			
CLEANING RADIATOR			
CHANGING AIR FILTER			
STORAGE			
RETURNING ENGINE TO SERVICE			
AUTOMATIC TRANSFER SWITCH			
ENGINE-GENERATOR SET			
MAINTENANCE SCHEDULE			

## SAVE THESE INSTRUCTIONS

This manual contains important instructions that should be followed during installation and maintenance of the generator. Read and understand all instructions in the manual before starting and operating the generator.

### USING THIS MANUAL

Congratulations on your choice of a WINCO generator. You have selected a high-quality, precision-engineered generator designed and tested to give you years of satisfactory service.

To get the best performance from your new generator, it is important that you carefully read and follow the operating instructions in this manual.

SHOULD YOU EXPERIENCE A PROBLEM PLEASE FOLLOW THE "TROUBLESHOOTING TABLES" NEAR THE END OF THIS MANUAL. THE WARRANTY LISTED IN THE MANUAL DESCRIBES WHAT YOU CAN EXPECT FROM WINCO SHOULD YOU NEED SERVICE ASSISTANCE IN THE FUTURE.

# SAFETY INFORMATION

## CALIFORNIA PROPOSITION 65

This product contains crude oil, gasoline, diesel fuel and other petroleum products, Antifreeze to which can expose you to chemicals including toluene and benzene, Ethylene glycol (ingested) which are known to the State of California to cause cancer, birth defects or other reproductive harm and developmental issues. For more information go to [www.P65Warning.ca.gov](http://www.P65Warning.ca.gov).

## WARNING: ELECTRICAL SHOCK

The output voltage present in this equipment can cause fatal electric shock. This equipment must be operated by a responsible person.

- A. Do not allow anyone to operate the generator without proper instruction.
- B. Guard against electric shock.
- C. Avoid contact with live terminals or receptacles.
- D. Use extreme care if operating this unit in rain or snow.
- E. Use only three-pronged grounded receptacles and extension cords.
- F. Be sure the unit is properly grounded for your application.

## WARNING: NOISE HAZARD

Excessive noise is not only tiring, but continual exposure can lead to loss of hearing.

- A. Use hearing protection when working around this equipment for long periods of time.
- B. Keep your neighbors in mind when using this equipment.

## NOTICE

Keep the generator and surrounding area clean.

- A. Remove all grease, ice, snow or materials that create slippery conditions around the unit.
- B. Remove any rags or other materials that could create a potential fire hazard.
- C. Carefully clean up any gas or oil spills before starting the unit.

## NOTICE

All service, including the installation or replacement of service parts, should be performed only by a qualified technician.

- A. Use only factory approved repair parts.
- B. Do not work on this equipment when fatigued.
- C. Never remove the protective guards, covers, or receptacle panels while the engine is running.
- D. Use extreme caution when working on electrical components. High output voltage from this equipment can cause serious injury or death.
- E. Always avoid hot mufflers, exhaust manifolds, and engine parts. They can cause severe burns instantly.
- F. The use of the engine-generator set must comply with all national, state, and local codes.

## WARNING: FIRE HAZARD

Gasoline and other fuels present a hazard of possible explosion and/or fire.

- A. Do not refuel when the engine is running or hot.
- B. Keep fuel containers out of reach of children.
- C. Do not smoke or use open flame near the generator set or fuel tank.
- D. Keep a fire extinguisher nearby and know its proper use. Fire extinguishers rated ABC by NFPA are appropriate.
- E. Store fuel only in an approved container, and only in a well ventilated area.
- F. Follow local codes for closeness to combustible material.

## WARNING

Exhaust fumes from any gasoline engine contain carbon monoxide, an invisible, odorless and deadly gas that must be mixed with fresh air.

- A. Operate only in well ventilated areas.
- B. Never operate indoors including attached garages.
- C. Never operate the unit in such a way as to allow exhaust gases to seep back into closed room (i.e. through windows, walls, floors).

## WARNING: PERSONAL INJURY

The muffler becomes very hot during operation and for a period after the unit has been turned off. Do not touch the muffler until it has completely cooled off.

# SPECIFICATIONS

## PSS65F4

### LP GAS - STANDBY

Wattage	60,000	65,000	65,000	65,000	65,000
Volts	120/240	120/208	120/240	277/480	346/600
kvA	60.0	81	81	81	81
Phase	Single	Three	Three	Three	Three
Amps	250	225	195	97	78
CB Size	250	225	225	100	80
Hertz	60	60	60	60	60

### NATURAL GAS - STANDBY

Wattage	58,000	58,000	58,000	58,000	58,000
Volts	120/240	120/208	120/240	277/480	346/600
kvA	58.0	72.4	72.4	72.4	72.4
Phase	Single	Three	Three	Three	Three
Amps	241	201	174	87	70
CB Size	250	225	225	100	80
Hertz	60	60	60	60	60

### LP GAS - PRIME

Wattage	54,000	58,000	58,000	58,000	58,000
Volts	120/240	120/208	120/240	277/480	346/600
kvA	54.0	72.4	72.4	72.4	72.4
Phase	Single	Three	Three	Three	Three
Amps	216	201	174	87	70
CB Size	250	225	225	100	80
Hertz	60	60	60	60	60

### NATURAL GAS - PRIME

Wattage	52,000	52,000	52,000	52,000	52,000
Volts	120/240	120/208	120/240	277/480	346/600
kvA	52.0	65.0	65.0	65.0	65.0
Phase	Single	Three	Three	Three	Three
Amps	216	180	156	78	62.5
CB Size	250	225	225	100	80
Hertz	60	60	60	60	60

### ENGINE

Model	Ford WSG873
Starting System	12 Volt
Muffler	Standard
Fuel Consumption	Full Load
LP	9.4 GAL/HR - 869,650 BTU/HR
NG	11.1 GAL/HR - 1,015,117 BTU/HR

### Generator Testing Resistance

Note: Review the Stamford Newage nameplate on your generator before selecting the correct information below.

Model	Stamford UCI224F
Winding Group	06
Resistances:	
Rotor	0.83 Ohms @22°C
Stator (L-L)	0.024 Ohms Per Ph @ 22°C
Exciter Rotor (L-L)	0.078 Ohms Per Ph @ 22°C
Exciter Stator (L-L)	20.0 Ohms @ 22°C
Voltage Regulator (L-I)	AS440

Model	Stamford UCI224F
Winding Group	311
Resistances:	
Rotor	0.83 Ohms @22°C
Stator (L-L)	0.065 Ohms Per Ph @ 22°C
Exciter Rotor (L-L)	0.078 Ohms Per Ph @ 22°C
Exciter Stator (L-L)	20.0 Ohms @ 22°C
Voltage Regulator (L-L)	AS440

# INTRODUCTION

## TESTING POLICY

Before any generator is shipped from the factory, it is fully checked for performance. The generator is loaded to its full capacity, and the voltage, current, and frequency are carefully checked.

Rated output of generator is based on engineering tests of typical units, and is subject to, and limited by, the temperature, altitude, fuel, and other conditions specified by the manufacturer of applicable engines.

## PRODUCT DESCRIPTION

The Package Standby System is designed to automatically provide standby power to unattended loads during electrical outages. Upon interruption of normal electrical service, the Packaged Standby System electrical control circuits will automatically start the engine. The generator will produce electrical power and the Automatic Transfer Switch (ATS) will automatically transfer the electrical loads to the engine-generator set. Upon restoration of normal electrical service the emergency transfer switch will sense return of the normal commercial power. The Automatic Transfer Switch will transfer the load back to the normal commercial power source. The engine controller has a programmable cool-down cycle that will begin if a time has been selected in the ECU program, and is indicated by a rotating hourglass on the display. After cool-down period the fuel supply will be shut off and the engine ignition system disabled.

### NOTICE

A Customer supplied 12 Volt battery is required to complete the installation. Battery requirements are listed later under the battery installation section.

The generator ships with an advanced DSE7310 digital controller. The DSE7310 will electronically display useful engine and generator performance information. The controller starts and stops the generator and monitors critical operating parameters and will shut the generator down to protect the engine from damage.

### GENERATOR SET:

Every WINCO generator set has its own unique identity data plate. This data plate identifies the complete unit model number, the system serial number, and has links to the individual components that form the generator set in our factory records. Several of the major components also have their own individual data plates providing additional information to document build data for warranty and replacements parts. Be sure to have the main WINCO unit data plate information recorded inside the front cover of this manual for future reference and for identification whenever requesting field or factory assistance.

**Primary fields needed for assistance are complete model number and serial number.**

### ENGINE:

This manual covers specific operation of the combined engine generator set. The basic engine information provided in this manual is not suitable for all operating conditions. Refer to the engine operators manual for more detailed operation and maintenance information.

### WARNING: EQUIPMENT DAMAGE

Be sure to check the engine oil level frequently as specified in the engine manual.

Engine service is available from a nearby authorized dealer or distributor. Go to the WINCO website ([wincogen.com](http://wincogen.com)) for a list of engine dealers or contact the WINCO Service Department.

The rated power of each engine-generator is limited by the temperature, altitude, and all other ambient conditions specified by the engine manufacturer.

### Derates

Above Sea Level > 2,000 FT	2% Every 500 Feet
Temperature > 104°F	4% Every 10°F

Units should not be operated in ambient temperature greater than 120° Fahrenheit.

### GENERATOR:

The nameplate includes a standby and prime/continuous rating. The standby rating is the maximum amount of power the generator set can produce. For prime power applications the load should be equal to or less than the prime power rating and the load is assumed to be variable. It is acceptable to occasionally reach the standby rating during prime operation to start motors or other temporary surges.

WINCO generator sets use a brushless, AVR (Auto-Voltage Regulator) controlled broad-range generator ends. The generator converts rotational mechanical energy into electrical energy. These WINCO units are equipped with generators manufactured by Cummins Generator Technologies. Each generator 'end' has its own data tag. A unique serial number is on the data plate and the data label is affixed to the main frame on the generator on the left side.

# PREPARING THE UNIT

## NOTICE

This engine is equipped with an O2 sensor. During the break in period you may get engine codes and limited output. After the engine operates with load for two to five hours the O2 sensor is conditioned and will allow full output without engine codes.

## START-UP CHECK LIST

A Start-Up Completion & Warranty Validation Form was sent along with this manual. This must be completed and returned to WINCO Inc. within 180 days of the factory invoice date.

If this form is not returned, the Warranty may be voided.

## UNPACKING

1. As you receive your unit, it is critical to check it for any damage. If any damage is noted, it is easiest to refuse the shipment and let WINCO take care of the freight claim. If you sign for the unit, the transfer of the ownership requires that you file the freight claim
2. Before proceeding with the preparations of your new generator for operation, take a couple of minutes to ensure the unit you have received is the correct model and review the specification pages in this manual to ensure that this unit meets your job requirements.

## NOTICE

These units are shipped with oil and a 50/50 mix of coolant. Be sure to check all fluid levels before operating. See engine manufacturer's instruction manual for recommended oil requirements before initial starting.

Once generator set is on-site:

1. Carefully remove the crate.
2. After inspecting the engine-generator for external, physical damage, locate and check the following items packed with the unit:
  - a. Installation and Operator's Manual.
  - b. Engine manufacturer's instruction manual.
  - c. Start-up and warranty validation form.
  - d. Battery hold-down brackets & hardware.
  - e. Unit components or accessory items shipped loose for on-site installation.
  - f. Optional accessories.
3. Remove main frame hold-down bolts.
4. Unit can now be lifted from shipping rails.

## LIFTING THE GENERATOR SET

### WARNING: PERSONAL INJURY

To prevent injury to persons or equipment, observe the following guidelines when lifting the generator:

Do not attempt to lift the generator set by the means of the lifting eyes on the engine or generator end. These lifting points are only for the use during the manufacturing process and are designed for lifting of the individual generator set components.

Due to the different designs, configurations, options, weights, site conditions, and available material handling equipment, specific lifting instructions are not provided for each individual generator set model. General guidelines provided are applicable to the entire generator line. It is the responsibility of the installing party to follow the lifting equipment's operator's manual to prevent injury to personnel and damage to the generator.

Smaller generator sets may not require use of overhead lifting equipment and may be placed on the pad with basic material handling equipment, i.e. a forklift. Always use forklifts of a proper rating and with long enough forks to move the generator. As the distance from the forklift mast increases the lifting capacity for the forklift decreases. When lifting from the side the forks should extend the entire width of the unit to the opposite side frame rail.

# INSTALLATION

This unit should be installed in a well ventilated area, ensuring the exhaust air cannot be recirculated back into the engine.

## NOTICE

This unit will get hot while it is running and for some time afterward.

## NOTICE

Before proceeding with the installation, be sure the engine control is in the “stop” position and the emergency stop depressed. Also, be sure the generator MLCB (main line circuit breaker) is in the “off” position and the unit starting battery is disconnected

Some configurations of the PSS65F4 are available with EPA Prime power certifications. These configurations are outfitted with a catalyst to meet current regulations. When operating prime power derate the load at least 10% for a variable load. If the load is continuous at one current rating ensure that it does not exceed 80% of the standby rating.

Prime power configurations can be installed in mobile or stationary applications as long as sound engineering practices are followed to accommodate the structural and cooling considerations outlined in this manual. Prime applications will require close observation of actual conditions requiring a shortening of maintenance intervals.

## GENERAL INFORMATION

Before beginning the installation process, recheck the voltage, phase, and amperage rating of the generator set. Be certain it can handle the intended load and is compatible with the intended loads. Plans for installation should be prepared with proper attention to mechanical and electrical engineering detail to assure a satisfactory system installation. The installation must comply with all national, state, and local codes.

The information in this manual is offered only as a guide to finalizing your installation plans and does not substitute for sound engineering judgment for the specific application.

## ENGINE-GENERATOR SET MOUNTING

These engine-generator sets are designed to be mounted on a pad where there is proper ventilation. The transfer switch is mounted next to your electrical entrance or distribution panel inside or outside the building. Consult a qualified, licensed electrician or contractor to install and wire the transfer switch. The installation must comply with all national, state and local codes. Before beginning the installation process check the rating of the generator set and its transfer switch rating. Be certain they can handle the intended load and are compatible with the entrance voltage, phase and current ratings. Plans for installation should be prepared with proper attention to mechanical and electrical engineering detail to assure a satisfactory system installation. The information in this manual is offered only as a guide to finalizing your installation plans.

## NOTICE

Never mount these engine-generator sets to a wooden base/structure. Over time, the wood will deteriorate and the unit mountings will come loose. These units must be mounted to a steel or concrete base.

## WARNING

The enclosures on these units can become very hot adjacent to the exhaust areas. Special care must be taken when installing these units to insure that the risk of contact by people is minimized.

The unit's main frame should be bolted to a pad that meets local code. Various materials, including concrete and composites, are acceptable as long as they are structurally sound supporting the weight of the unit and preventing movement during operation. The mounting holes on the base of this unit are 0.625" in diameter. The engine-generator is mounted on a sub-frame which is isolated with special shock mounts on the main frame. This allows the engine-generator to vibrate without affecting the control panel on the main frame.

Do not install any shock mounts between the base frame and the pad. Engine vibration will be transmitted to the control panel causing erroneous start/stop cycles and premature control failure.

These units should be mounted a minimum of 24" from a structure. This will allow for ample room to maintain and work on the generator set.

Units must be installed in accordance with all local, state, and national codes. Consult your local agency for specific requirements.

## VENTILATION REQUIREMENTS

### OPEN SKID

## WARNING: EQUIPMENT DAMAGE

It is the installer's responsibility to ensure that there is sufficient cooling air available to prevent the engine and generator from over heating. Damage caused by overheating is not covered by warranty.

## WARNING: EQUIPMENT DAMAGE

Failure to seal the radiator output will result in hot air recirculation that will result in equipment overheating and damage. Their fresh air inlets should be 1½ to 2 times larger than the radiator face. The extra air inlet area is required to minimize restriction and to provide combustion air for the engine. Do not block fresh air intakes with other equipment as this will result in insufficient air flow to the engine for cooling. Installing them opposite the hot air discharge will allow a sweeping flow of cooling air across the engine, preventing hot spots.

Providing proper air movement during your installation planning is essential. You will need to provide a fresh air inlet as well as a hot air outlet (to the outside of protection housing) for proper engine performance. These engine-generator sets are equipped with unit mount radiators and the engine is equipped with a pusher type fan. The hot air from the face of the radiator must be ducted out of the enclosure to ensure proper cooling. Failing to do so will

allow the hot air to recirculate around the radiator causing the engine to overheat, resulting in an engine shutdown and damage. If louvers are used in front of the hot air duct to protect the unit from outside weather, the louvers should be 1½ times as large as the area of the radiator face to prevent back pressure.

Foam or other seals can be used to form a tight lip forcing all of the air from the engine fan out of the enclosure. In addition to a hot air discharge, you must plan a fresh air intake opposite the radiator discharge. Their fresh air inlets should be 1½ to 2 times larger than the radiator face. The extra air inlet area is required to minimize restriction and to provide combustion air for the engine. Do not block fresh air intakes with other equipment as this will result in insufficient air flow to the engine for cooling. Installing them opposite the hot air discharge will allow a sweeping flow of cooling air across the engine, preventing hot spots.

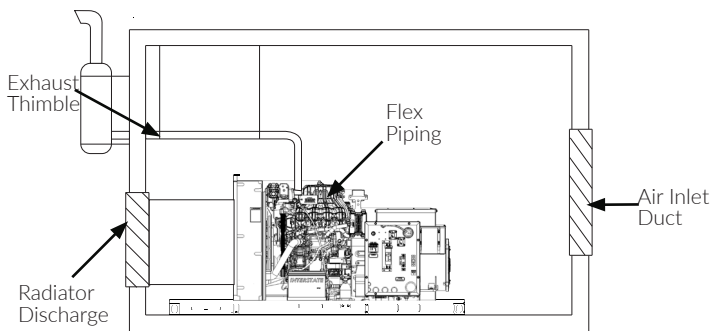

The WINCO installation manual OPM-112 contains additional information on indoor, open skid installations and is available electronically through our website or by requesting a copy from the factory.

## EXHAUST INSTALLATION

### WARNING

Improper exhaust installation will allow dangerous gases to seep into enclosed spaces causing a hazard to your health and/or death.

All exhaust must be piped out of the enclosure. When selecting a location to exhaust fumes make sure that the potential for contact with people is controlled. Exhaust can enter buildings through windows, ventilation systems and other openings if proper precautions are not followed.

The exhaust must be isolated from the vibration of the engine. If the exhaust is connected in a rigid system it will result in damage to the engine. The generator comes equipped with an engine mounted flex pipe to aid your installation. Ensure proper alignment with the generator. The flex can be eliminated if it is pushed to one side to make a connection.

The most direct path possible should be used to route the exhaust outside of the enclosure. Each bend restricts the pipe and increases back pressure. It may be necessary to increase the exhaust pipe diameter in some applications.

The exhaust pipe is very hot. When passing through the structure it is critical that a thimble or other appropriate technique is used to dissipate the heat and prevent the

structure from catching on fire.

It is preferable to exhaust out the side of the enclosures. Slope the pipe slightly downward away from the engine to cause any water in the exhaust to run away from the engine. Do not exhaust near intake. Once outside the enclosure a rain cap or other technique must be used to keep water out of the exhaust. In mobile applications make sure the rain flap faces to the rear of the vehicle so that it is not blown open during transportation.

The generator ships with a critical grade muffler that should be installed to decrease noise. It can be mounted either internally or externally to the enclosure. The muffler cannot increase back pressure to more than 0.725 psi.

## FUEL INSTALLATION

The fuel supply should be as close as possible to the engine. This will reduce the installation cost of fuel runs. The information in this manual is offered to assist you in providing the proper fuel for your engine. However, this information is only provided to inform you of the engine's requirements and assist in making you aware of the decisions you must make. In no case should the instructions and information provided be interpreted to conflict with any local, state or national codes. If in doubt, always consult your local fire marshal, gas supplier or building inspector.

### WARNING

All fuel runs should be installed by a licensed fuel supplier.

To connect the fuel line to the generator set you will connect your incoming fuel line to the 1.25 inch NPT fitting located on the left side of the engine-generator set. This fitting is shipped with a plastic plug installed to insure the fuel system stays clean. For all vapor fuel systems the delivery pressure of the fuel to the fuel solenoid on the unit must be four to six ounces psi (per square inch) or 7 to 11 inches W.C. (water column). These fuel pressures are critical; failure to provide the proper pressure can cause many problems including failure to start, inability to produce full power, or damage to the equipment.

These generators have been tested with both natural gas and LP at the factory. Before starting the engine you must verify it is configured for the proper fuel. See additional information in the NG/LP conversion section.

## INSTALLING THE FUEL LINE

NOTICE: The engine generator sets are properly adjusted before they leave the factory. The electronic control panel will indicate if the LP mode is active

### NATURAL GAS or LP VAPOR PIPE SIZE

Size of pipe normally required for generators operating on natural gas or LP vapor. Unit location will determine the size of fuel line that is required to supply the engine with a constant fuel pressure and volume.

## LIQUID PROPANE VAPOR (LP)

Refer to the tables on the following pages for fuel line size and recommended tank size. For distances of 25 feet or greater, a two regulator fuel system is recommended. This is accomplished by installing a primary regulator at the tank

which will reduce the tank pressure down to 10 to 15 lbs. A low pressure regulator is installed to further reduce the fuel pressure to the required six (6) oz. operating pressure. This low pressure regulator must be at least 10 feet from the engine generator set; any closer installation will require a larger line be installed to provide a fuel reservoir. This is also true for the single low pressure regulator, it should also be a minimum of 10 feet from the unit. If this is not done, the demand regulator on the unit and the pressure regulator in the fuel line will interfere with each other. When the two (2) regulator system is used on LP, a fuel line size of 3/4 to 1 inch is generally adequate for distances up to 300 feet from the primary to the low pressure regulator. Consult your local fuel supplier for your exact requirements. The appropriate line size from the following table is then installed from the low pressure regulator to the generator set.

Feet*	Size of pipe
Up to 25 ft	1.25" pipe
25 - 100 ft	1.25" pipe
Over 100 ft	Use a two regulator system

\*Allow an additional 3 feet for each standard elbow. DO NOT use 'street ells' (restrictive).

### LP TANK SIZING

Tank size is based off of 75% load, tank level has more than 20% capacity, and tank is dedicated for the generator supply.

Tank Temperature	Tank Size
32° F (0° C)	1000 Gallons
0° F (18° C)	2000 Gallons
-20° F (-29° C)	3000 Gallons

### LIQUID WITHDRAWAL SYSTEMS

When installing a unit equipped with the LP liquid withdrawal, a primary regulator is not required on the supply tank. The supply line is connected to a liquid withdrawal valve on the supply tank and runs directly to the fuellock strainer mounted on the engine generator set. Normally a 3/8 to 1/2 inch copper line is acceptable for this type of fuel installation. You must be sure that the valve you have connected to on the supply tank is in fact a liquid supply valve and has a drop tube inside the tank that is pulling fuel from the bottom of the supply tank. Before starting the unit, you must confirm that you have a good liquid supply at the unit. Engine generator sets equipped for liquid withdrawal will not run properly when supplied with vapor fuel.

### NATURAL GAS (NG)

The primary regulator (fuel meter) on the building should deliver the correct volume and pressure to the generator set. This regulator must be sized to deliver the required BTU's to the generator set and all other appliances in the building. If the primary regulator (fuel meter) is a high pressure regulator, then a low pressure regulator must be installed to bring the pressure down to 4-6 oz. (7-11 inches water column) of pressure. This low pressure regulator must be at least 10 feet from the engine generator set; any closer installation will require a larger line be installed to provide a fuel reservoir. If this is not done, the demand regulator on the unit and the pressure regulator in the fuel line will

interfere with each other. This regulator must be sized to accommodate the demand of the generator set and any other appliance connected to it. See the following table for the correct size of pipe to be installed.

Feet*	Size of pipe
Up to 25 ft	1.25" pipe
Over 25 ft*	1.25" pipe

\*Allow an additional 3 feet for each standard elbow. DO NOT use 'street ells' (restrictive).

#### WARNING

Do not use galvanized pipe in fuel line runs. The galvanized coating can become eroded and flake off, causing possible obstructions in the regulator or fuel valve. The results could range from inoperative engine to hazardous fuel leaks.

#### NOTICE

Be careful when sealing gas joints. Excessive sealing compound can be drawn into the solenoid, regulator or carburetor causing an engine malfunction.

### FUEL PRESSURE

Correct fuel pressure cannot be stressed enough. The most common cause for inoperative systems is an inadequate or incorrect fuel pressure. Performance of the engine is in direct relation to the correctness of the fuel system. Shown below is a diagram of a typical LP vapor fuel installation. Notice the following tables give two different units of measuring fuel pressure. The first and most accurate is the use of a simple water manometer. A manometer is calibrated in inches of water column. The second is with a pressure gauge calibrated in ounces per square inch.

#### TWO REGULATOR FUEL SYSTEM

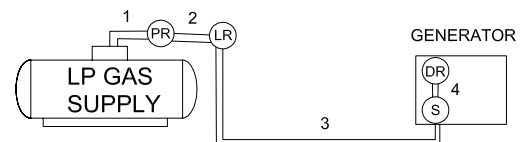

LEGEND:  
 PR - PRIMARY REGULATOR (Reduces tank pressure to 10 - 15 PSI (pounds per square inch))  
 LR - LOW PRESSURE REGULATOR (Reduces fuel pressure to 4 to 6 oz. (ounces per square inch))  
 S - FUEL SOLENOID VALVE (Positive shut-off solenoid)  
 DR - DEMAND REGULATOR (Requires engine vacuum to open)

#### DUAL STAGE SINGLE REGULATOR SYSTEM

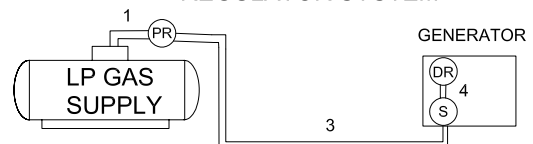

LEGEND:  
 PR - PRIMARY REGULATOR (Reduces tank pressure to 4 to 6 oz.)  
 S - FUEL SOLENOID VALVE (Positive shut-off solenoid)  
 DR - DEMAND REGULATOR (Requires engine vacuum to open)

Reference in both diagrams: numbers 1 through 3 in the diagram above are system parts supplied by the customer. Reference number 4 is on the generator. The following diagram is of a natural gas (NG) installation.

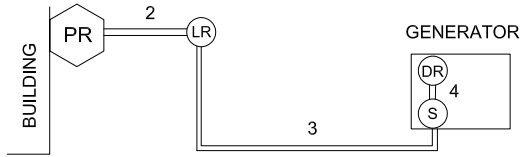

**LEGEND:**

- PR - PRIMARY REGULATOR (Fuel Meter)
- LR - LOW PRESSURE REGULATOR (Reduces fuel pressure to 4 to 6 oz. (ounces per square inch) IF REQUIRED)
- S - FUEL SOLENOID VALVE (Positive shut-off solenoid)
- DR - DEMAND REGULATOR (Requires engine vacuum to open)

Reference numbers 2 through 4 in the previous diagram are system parts supplied by the customer. Reference number 4 is on the generator.

**FUEL PRESSURE TABLES**

The following tables are the fuel pressure readings at each reference in the system.

**SINGLE LOW PRESSURE REGULATOR (LP VAPOR ONLY)**

Ref#	1	3	4
Unit off	Line PSI	7-11 in 4-6 oz	7-11 in 4-6 oz
Starting	Line PSI	7-11 in 4-6 oz	7-11 in 4-6 oz
No load	Line PSI	7-11 in 4-6 oz	7-11 in 4-6 oz
Full load	Line PSI	7-11 in 4-6 oz	7-11 in 4-6 oz

**TWO REGULATOR SYSTEM (LP VAPOR ONLY)**

Ref#	1	2	3	4
Unit off	Line PSI	10-15 lbs	7-11 in 4-6 oz	7-11 in 4-6 oz
Starting	Line PSI	10-15 lbs	7-11 in 4-6 oz	7-11 in 4-6 oz
No load	Line PSI	10-15 lbs	7-11 in 4-6 oz	7-11 in 4-6 oz
Full load	Line PSI	10-15 lbs	7-11 in 4-6 oz	7-11 in 4-6 oz

**NATURAL GAS**

Ref#	2	3	4
Unit off	2 PSI	7-11 in 4-6 oz	7-11 in 4-6 oz
Starting	2 PSI	7-11 in 4-6 oz	7-11 in 4-6 oz

No load	2 PSI	7-11 in 4-6 oz	7-11 in 4-6 oz
Full load	2 PSI	7-11 in 4-6 oz	7-11 in 4-6 oz

**NG/LP FUEL CONVERSION**

This generator set was tested on both LP and NG at the factory. Ensure proper fuel configuration before operating.

**NOTICE**

Do not make any fuel adjustments or governor adjustments until all pressure readings are in compliance with specification.

These engine/generator sets are easy to convert between LP or NG. As the engine timing is controlled by the ECU on the engine you only need to tell it what fuel you want to operate on. A small rocker switch has been provide on the underside of the engine control cabinet for this purpose.

Opening the rocker switch will tell the ECU mounted on the engine that you are operating on NG Fuel. Closing the rocker switch will tell the ECU that the fuel being supplied is LP. The Advance Power Controller has an indicator light for LP. When this light is on, the engine is set-up for LP, when the LP light is out the engine is set up for NG. The ECU will then reprogram the engine to operate on the proper fuel.

# ELECTRICAL CONNECTIONS

## AC ELECTRICAL CONNECTIONS

NOTICE: CLASS 1 WIRING METHODS ARE TO BE USED FOR ALL FIELD WIRING CONNECTIONS TO TERMINAL OF A CLASS 2 CIRCUIT.

### WARNING

A mainline circuit breaker has been provided inside the generator housing. During all wiring installation, make sure the breaker is in the off position and the generator operators switch is in the off position.

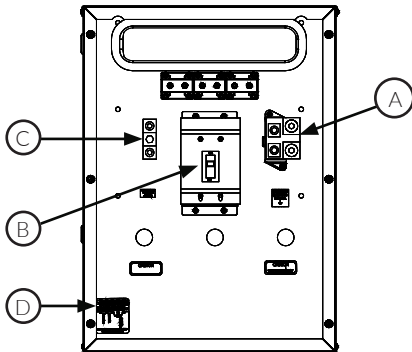

A - Neutral Lugs, These neutral lugs are isolated from ground and provided for you to connect your neutral wire from the transfer switch. The lugs on the PSS65 will handle wire sizes #4 AWG to 300 MCM and should be torqued to 250 in lbs.

B - Generator Circuit Breaker, This circuit breaker provides overload protection for the generator. Your power feeds from the transfer switch will connect to the bottom lugs on the circuit breaker. The generator power feeds have already been wired into the upper lugs.

The table below gives you the circuit breaker size, lug wire sizes (see the actual breaker for additional information and restrictions)

Volts	PH	Amp	Wire Capability
120/240	1	250	(1) #1 AWG-600 kcmil or (2) #1 AWG-250 kcmil
120/208	3	225	(1) 4 AWG-300 kcmil
120/240	3	225	(1) 4 AWG-300 kcmil
277/480	3	100	(1) #14 - #3/0 AWG
346/600	3	80	(1) #14 - #3/0 AWG

The following table shows the minimum conductor sizes between the generator and the ATS, based on wire type and temperature rating. Wire has been derated 40° C ambient temperatures.

Volts	PH	Amp	Wire Temperature Rating			
			Cu Conductor		Al Conductor	
			75°C	90°C	75°C	90°C
120/240	1	250	300	4/0	500	350
120/208	3	225	250	4/0	400	300
120/240	3	225	250	4/0	400	300
277/480	3	100	2	3	1/0	1
346/600	3	80	3	4	2	3

For additional information on wire sizing refer to table 310-16 of the National Electrical Code ANSI/NFPA 70.

C - Ground Lug, These ground lugs are bonded to ground and are provided for you to connect your ground wire from the transfer switch to. The lugs on the PSS65 will accommodate #1 AWG to 250 MCM and should be torqued to 250 in. lbs.

D. 120 Volt Terminal Block. These terminals are for shore power. For a power line with one lead, plug into either terminals, ensuring the jumper is still connected. To isolate two leads for use of two separate circuit breakers, the jumper must be removed.

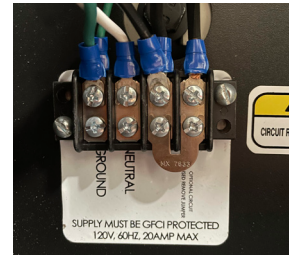

### WARNING: EQUIPMENT DAMAGE

When installing a three-phase 240 Volt system, be sure you know which lead is the high voltage "wild" leg (208 Volt line to neutral). The generator normally carries the high voltage on the G2 lead.

The load current carrying wires (L) and (T) must be sized to handle the maximum load current without excessive voltage drop. By code, the wire must be heavy enough to handle the full current rating of the mainline circuit breaker (or fuse) in the entrance (or sub-panel) protecting the contactor switch.

All wires should be installed in rigid or flexible conduit. (knockouts are provided in the control box).

## GROUNDING

A grounding lug has been provided on the engine generator set. Proper grounding of your generator is application dependent. Carefully evaluate your planned use of your generator to understand which grounding you require. If you are not sure what to do, contact a competent professional to assist you. The NFPA 70 250:34-35 are good technical references. .

## DC ELECTRICAL CONNECTIONS

### NOTICE

Never run the AC and DC wiring on the same conduit.

NOTE: There are various DC connectors on the engine that have nothing connected to them. This was done intentionally, the connectors are for END OF THE LINE TESTING and other diagnostic tests. They are not used during normal operations and can just be ignored.

All DC connections are completed on the DIN rail terminal blocks just inside the engine control cabinet, behind the DSE7310.

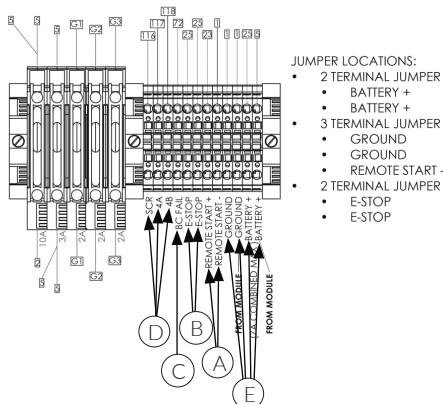

**A - Customer Remote Start CONNECTIONS TERMINALS.** The two remote start leads from the Automatic Transfer Switch are connected to the two terminals marked 1 & 23. The wire in terminal labeled #1 is Battery Negative/Ground and the wire in the terminal labeled #23 is your Remote Start lead. Closing these two leads together will signal the DSE 7310 MKII to go into an autostart mode and start up the engine generator.

Depending on the distance, 14 to 16 gauge stranded wire should be used. It is suggested that these wires be labeled S1 and S23.

Note: Any relay closure can be used to start and stop this generator. As long as the contact stays closed the engine generator set will continue to run. Once the relay is opened the unit will shut down after any cool down timers programmed into the Automatic Transfer Switch and/or the DSE 7310 Controller, and remain in the standby mode until the remote start relay is closed again.

**B - ESTOP- & ESTOP+.** Remote Emergency Stop terminals. These two terminals are shipped with a jumper installed. If your application requires the installation of a Remote Emergency Stop switch, remove the jumper and wire your switch to these terminals. This unit will not start and run without either the jumper installed or a remote N/C switch installed..

**C - Battery Charger Failure.** Battery charger failure relay input from remote battery charger to DSE7310 MKII controller.

**D - Remote Display Panel Interface Terminals.** These interface terminals are pre-wired to allow for the connection of a remote display. This display allows for the remote annunciation of alarms at a location such as a nurses station or a control room.

**E - Battery Positive and Ground ( battery negative).** These terminals are dedicated for any accessory that will be installed. There is a maximum of 7 Amps combined.

## DC INTERCONNECTIONS TO ATS

Two control wires are required between the ATS panel and the generator control terminal box. Depending on the distance, 14 and 16 gauge stranded wire should be used. These wires should be labeled S1 and S23.

### WARNING

Be sure engine generator is in the OFF position before you make any DC interconnections.

## TRANSFER SWITCH

### NOTICE

For full service switching of the entire load, the ATS must be 'SE' (Service Entrance) rated or must have a properly rated fusible disconnect installed before the ATS to protect the contacts.

### WARNING

All wiring must be done by a licensed electrician, and must conform to the National Electrical Code and comply with all the local codes and regulations. Check with the local authorities before proceeding.

## ASCO 185 UL SWITCH

Your DC connection points in the ASCO 185 UL ATS are on the terminal block on the bottom of the controller in the lower left hand corner of the ATS panel. The terminal block (TB7) is numbered 1 through 9. These terminals will accept # 22 - # 14 AWG stranded wire. It is recommended that you use # 16 AWG for distances up to 200 feet. You need to run two (2) wires from the engine generator set to the transfer switch. You will be using terminals 4 and 5, wire Start # 23 will connect to terminal # 5 and wire Battery Negative # 1 will connect to terminal # 4. See the following table and illustration.

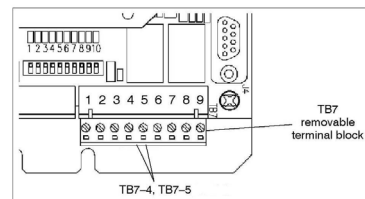

Your DC connection points in the ASCO 185 ATS are terminals "4" and "5" on the interface terminal block. As this is a "DRY" unpowered set of contacts, it makes no difference which lead (battery negative #1 or start #23) connect to which terminal.

## ASCO 300 UL SWITCH

When Normal Source Fails	Terminals On Transfer Switch
Contact Closes	TB1 and TB2
Contact Opens	TB1 and TB3

Engine start and auxiliary circuit terminal block TB located on 3ATS & 3NTS transfer switch.

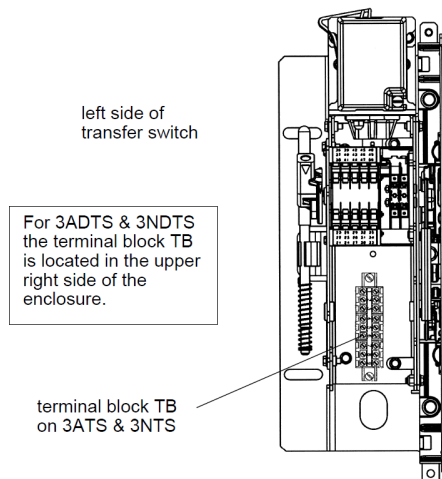

## MOUNTING THE ATS

See the ASCO installation manual for additional details on proper wiring of the Automatic Transfer Switch.

### INSTALLATION NOTES:

Because of the many different types of service, feeder, and distribution equipment, no specific wiring instructions can be provided. It is recommended that only copper wire be used. In all cases it is essential that while the load is connected to the generator, there can be absolutely no feedback from the generator to the power line or the power line to the generator. When properly installed, the normal A.T.S. Control and safety systems will eliminate all paths for feedback.

To wire the automatic transfer switch into the existing wiring, first determine which circuits will be on the emergency load circuit. If the entire load is to be transferred, the transfer switch can be wired in directly after the watt-hour meter and the service entrance, providing the service entrance ampere rating is within the transfer switch's rated capability.

If only specific circuits are to be powered under emergency power failure conditions, an additional distribution panel designated "emergency distribution panel" must be installed.

All selected emergency circuits are removed from main distribution panels and installed in the emergency distribution panel. The A.T.S. is then installed between the main panel and the emergency distribution panel. Suggested circuits: freezer, refrigerator, furnace, emergency lights, sump pump, emergency outlet circuits, etc. Total running load must not exceed generator rating.

### **WARNING**

A service disconnect must be installed in front of the ATS panel if the ATS is not service entrance rated. This will allow you to test the generator under load. Should you ever have to work on the switch, you will be able to disconnect the power and work on the switch cold without having the power company pull your meter.

# INSTALLING THE BATTERY

## WARNING

In the following battery installation procedure, check to be sure the ComAp IntelliNano is in the “stop” position. This should be your last step before initial start-up.

A customer supplied twelve-volt battery is required to complete the installation. Installation of the highest CCA rated battery, within the correct BCI group (size), will increase cold weather starting performance. **Gel batteries should not be used** with the battery tender installed in the generator enclosure.

Voltage	BCI Group	MIN. CCA Rating
12	24	650

## NOTICE

This unit is 12 Volt and is negative ground. Permanent damage will occur if they are connected to a 24 Volt system or a positive ground system. If you are using the truck batteries to start these units, you may have to disable the charging system to keep it from interfering with the vehicle charging system.

Installation and servicing of batteries must be performed or supervised only by persons knowledgeable of batteries and the required precautions. Keep unauthorized persons away from batteries. When installing or replacing batteries, use the proper group/size starting battery. The battery should be a maintenance free lead acid design. Deep cycle batteries **will not work** for this application.

## WARNING

1. Never smoke when near batteries. 2. Do not cause a flame or spark in the battery area. 3. Always discharge static electricity from your body before touching batteries by first touching a ground metal surface.

## NOTICE

NEVER dispose a battery in a fire. The battery is capable of exploding. DO NOT open or mutilate the battery. Released electrolyte is known to be harmful to the skin and eyes and to be very toxic. These engine-generator sets are all NEGATIVE ground. Be very careful not to connect the battery in reverse polarity, as this may short circuit the battery charging system on the engine.

## NOTICE

A battery presents a risk of electrical shock and high short circuit current. The following precautions must be observed when working with batteries: 1. Remove watches, rings, and other metal objects. 2. Use tools with insulated handles. 3. Check both the battery cable ends and the battery posts to be sure they are free of corrosion. 4. Always connect the battery positive cable first and then connect the battery negative cable. When removing the battery cables from the battery, reverse the procedure, disconnect the negative first and then the positive cable. 5. Be sure all connections are tight and coat the terminals and cable ends with dielectric grease.

## WARNING

The electrolyte is diluted sulfuric acid that is harmful to the skin and eyes. It is electrically conductive and corrosive. The following precautions must always be taken. 1. Always wear full eye protection and protective clothing. 2. Where electrolyte contacts skin, wash off immediately with water. 3. If electrolyte contacts the eyes, flush thoroughly and immediately with water and seek immediate medical attention. 4. Spilled electrolyte is to be washed down with an acid neutralizing agent. A common practice is to use a solution of one pound of bicarbonate of soda (baking soda) to one gallon of water. The bicarbonate of soda solution is to be added until the evidence of reaction (foaming) has ceased. The resulting liquid is to be flushed with water and the area dried.

## WARNING: EQUIPMENT DAMAGE

Never attempt to jump start this engine. If the battery should accidentally become discharged, disconnect the battery cables and recharge the battery before attempting to start the unit. Boost/jump starting this unit improperly will result in PERMANENT DAMAGE TO THE ENGINE CONTROL MODULE (ECM).

## NOTICE

This unit is 12 Volt and is negative ground. Permanent damage will occur if they are connected to a 24 Volt system or a positive ground system. If you are using the truck batteries to start these units, you may have to disable the charging system to keep it from interfering with the vehicle charging system.

## SERVICING BATTERIES

The Cells in the Starting Battery may lose water over time. This is especially true if you are using a trickle charger to maintain your battery. When refilling the battery with water, use only distilled water. Tap water will shorten the service life of the battery.

Never fill the battery above the fill line. Over filling above the upper level line may cause electrolyte to overflow, resulting in corrosion to the engine or nearby parts. Immediately wash off any spilled electrolyte following the procedure above.

## BATTERY CHARGING

This generator is equipped with an engine mounted alternator that will recharge the battery during operation. It is not necessary to have the battery charger circuit on the emergency distribution circuit.

## NOTICE

Always connect the positive cable first and the negative cable last. When disconnecting, remove the negative cable first and the positive cable last. Failure to connect and disconnect in the proper sequence can cause equipment damage.

Observe polarities: connect the positive (+) battery terminal to the (+) cable from the engine starter; the negative (-) battery terminal is connected to the negative cable (ground) from the engine generator frame. All connections must be

clean and tight. Check the electrolyte (fluid) in the battery periodically to be sure it is above the plates. Never allow the battery to remain in a discharge condition.

### **WARNING: EQUIPMENT DAMAGE**

Never attempt to jump start this engine. If the battery should accidentally become discharged, disconnect the battery cables and recharge the battery before attempting to start the unit. Boost/jump starting this unit improperly will result in PERMANENT DAMAGE TO THE ENGINE CONTROL MODULE (ECM).

## **BATTERY CHARGER & BLOCK HEATER**

### **BATTERY CHARGER**

A three-stage, on-board marine battery charger is provided standard on this unit. The charger is a 5 amp dual use maintainer and charger designed to keep your batteries fully charged by maintaining them automatically.

Make sure all DC battery connections are tight and clean. Follow battery manufacturer's recommendations.

This charger is mounted under the customer connection on the control side of the generator. The charger will need to be plugged to a customer's power source, using a customer supplied heavy duty, UL approved extension cord. The receptacle is to be powered by a GFCI circuit and installed in accordance to the US National Electric Code. It is suggested that this circuit be fused to 20 Amps.

Low/Charge Mode:

The illuminated blue power LED and red low/charging LED. This indicates the Low/Charge mode is in process. When completed the RED Low/Charge LED will turn off.

Auto Maintain Mode:

The illuminated Green auto maintain LED. This indicates your 12 volt battery is fully charged. During short or long term storage periods, Auto Maintain (Energy Saver) mode will monitor and auto maintain a battery only when needed to maintain a full state of charge. This feature significantly reduces AC Power consumption, lowers operating costs and maximizes reserve power performance.

### **BLOCK HEATER**

The block heater on this unit is a 1500 watt heater and can use the same 20 Amp GFCI fused circuit. The circuit will terminate on the 120 Volt terminal block mount in the customer connection cabinet. The engine block heater installed on this unit should also be plugged into this receptacle. The block heater is thermostatically controlled when plugged in will maintain the engine coolant temperature between 100 and 120 degrees F.

# STARTING PROCEDURE

## WARNING

For the first 10 seconds of operation all of the oil, coolant, and electrical shutdowns are disabled. This is enough time to cause catastrophic damage to the equipment if the pre-start checklist is not properly completed and proper maintenance isn't consistently followed.

## LUBRICATION

Before starting the engine, check the oil level in the crankcase. If it is low, refill to the full mark with the proper weight/grade of oil as recommended by the engine manufacturer's maintenance instructions. The necessity of using the correct oil and keeping the crankcase full cannot be over emphasized. Failure to do so will cause excessive engine wear and shorten its useful life.

Winco recommends our 5W-30 fully synthetic heavy duty engine oil to give you maximum cold weather protection while maintaining excellent performance in warmer weather. We have partnered with a national lubrication oil manufacturer to give you access to Winco private branded premium oil available at comparable prices to conventional oils. See your dealer for additional information.

## COOLANT

Before starting the engine, Check the coolant level in the radiator. If it is low, refill as specified in the engine manufacturer's maintenance instructions.

## PRE-START CHECK LIST

F-153 Start-Up Completion & Warranty Validation form was sent with your generator. This form must be filled out by an Authorized WINCO Service Center and submit it to our WINCO Service Department for your warranty to become valid. After completing the checklist, the engine-generator set is ready for initial start-up.

## NOTICE

Before attempting to start this unit, complete your pre-start checklist and ensure the generator mainline circuit breaker is in the proper position prior to starting. Starting this unit without it properly connected can cause serious personal injury or equipment damage.





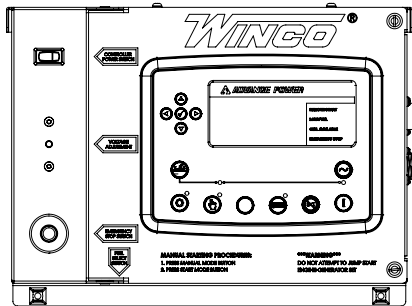

DO NOT jump start these engine-generator sets. Starting these units on a low battery or jump starting them will cause damage to the engine control module.

## NOTICE

This engine is equipped with an O2 sensor. During the break in period you may get engine codes and limited output. After the engine operates with load for two to five hours the O2 sensor is conditioned and will allow full output without engine codes.

# CONTROL LAYOUT



	<p><b>STOP/RESET</b> - This button places the module into its Stop/Reset mode. This will clear any alarm conditions for which the triggering criteria have been removed. The fuel supply de-energizes and the engine comes to a standstill. Should a remote start signal be present while operating in this mode, a remote start WILL NOT occur. If a cool down period has been programmed then hitting this button once when engine is running will initiate the cool down timer, which will be indicated on the display by a rotating hourglass. Hitting this button a second time will bypass the cooldown timer.</p>
	<p><b>MANUAL MODE</b> - This button places the module into its Manual Mode. Once in Manual Mode, the model responds to the Start button to start the generator and run it off load.</p>
	<p><b>START</b> - Pressing this button from MANUAL MODE will start the engine and run the load.</p>
	<p><b>AUTO MODE</b> - This button places the module into its Auto Mode. This mode allows the module to control the function of the generator automatically.</p>
	<p><b>ALARM/LAMP TEST</b> - This button silences the audible alarm in the controller, deactivates the Audible Alarm output (if configured) and illuminates all of the LEDs on the module's face as a lamp test function.</p>
	<p><b>MENU NAVIGATION</b> - Used for navigating the instrumentation, event log, and configuration screens.</p>
	<p>A small rocker switch is located on the underside of the engine control cabinet.</p> <p>On gaseous models, the engine timing is controlled by the ECU on the engine and you need to tell it what fuel you want to operate on; LP or NG.</p> <p>On diesel models, this switch has been disconnected and will do nothing.</p>

## PROTECTIONS

When an alarm is present, the common alarm LED, if configured, will illuminate. The LCD display will show an icon to indicate the failure.

## WARNINGS

Warnings are non-critical alarm conditions. They do not affect the operation of the generator system, they serve to draw the operator's attention to an undesirable condition. Warning alarms are self-resetting when the fault condition is removed. The icon will appear steady in the display.

## SHUTDOWN

Shutdowns are critical alarm conditions that stop the engine and draw the operator's attention to an undesirable condition. Shutdown alarms are latching. The fault must be removed and the STOP/RESET button pressed to reset the module. The icon will be flashing in the display.

## MANUAL MODE

1. Press and release the Manual Mode button. The small LED light next to it should come on.

Note: There is no start delay in this mode of operation.

2. Press and release the green Start Engine button. The DSE 7310 will send two signals to the engine. The first signal wire #21 will engage the fuel solenoid, the second wire, #22, will engage the starter on the engine. At this point the DSE 7310 will start the cranking cycle (10 seconds on and 10 seconds off).

If the engine fails to start during this cranking period, the starter motor is disengaged and goes into a rest mode after which a second attempt is made to start the engine. Should this sequence continue through 3 cranking cycles the start sequence will be stopped and the display will show 'FAILED TO START'.

3. During manual operation, the load will not normally be applied to the generator. But caution must be used, if the line power should fail or be turned off the transfer switch during manual operation the load may be applied to the generator.

With the engine running smoothly check the no load voltage and frequency on the digital display. The voltage should match the nameplate and a frequency of 59.5 to 60.5 hertz (Hz).

If you have the proper voltage at the generator the next step is to check the voltage at the generator terminals in the Automatic Transfer Switch. The voltage between the G1 and the G3 terminals should be the same as it was on the generator front panel. The voltage should also be checked between the hot terminals (G1 and G3) and the G-N to be certain of a balanced voltage output and a solid neutral connection. The voltage between G1 and G-N should be about 120 volts AC (277 on 480 units). The same approximate voltage should be found between terminals G3 and G-N (120 volts AC).

On three phase panels the G2 voltage level should also be checked. ON 240 VOLT (DELTA) SYSTEMS BE SURE YOU KNOW WHERE THE HIGH VOLTAGE "WILD" LEG IS. IT MUST BE IN THE SAME LOCATION ON THE LINE SIDE AS IT IS ON THE GENERATOR SIDE. (i.e. if it's on L-3 on the line side it must be on G-3 on the generator side. Also on three phase systems make sure that the

rotation is the same on the generator as it is on your line power.

battery charger can be plugged in to an extension cord on mobile applications.

#### **WARNING**

Failure to insure proper rotation will cause three phase motors to spin backwards, possibly damaging motors and equipment.

#### **NOTICE**

If for any reason during the check out procedure the voltage and frequency are not correct, depress the STOP/RESET button and correct the trouble before proceeding.

4. Stopping - There are two ways to stop the unit when it is in the manual mode. Pressing the STOP/RESET button will stop the unit immediately. Pressing the AUTO mode button will stop the unit but only after the cool down timers have timed out and there is no remote start signal being sent to the unit.

#### **NOTICE**

Always make sure the generator runs under no load for five minutes before stopping to allow the engine and components to cool down. Don't use the E-Stop as the standard.

### **AUTO MODE**

To activate the automatic start mode you will just need to depress the AUTO button, the LED indicator beside the button confirms that the unit is in automatic mode.

To test the Automatic Transfer Switch, follow the instruction on the operator's manual that came with the transfer switch. If you get a fault during the initial start up or prior to start up, it is most likely a false warning light. Simply reset the ATS to start over.

Once you have completed testing of the ATS, be sure you ALWAYS leave the system in the standby mode, unless servicing the unit. For standby operation, press the AUTO button on the front of the control. The green light should light up next to the AUTO button.

NOTE: For setting the exerciser circuit, for all ATS, see the operator's manual shipped with the ATS.

### **CONTROL POWER**

The DSE7310 controller consumes small amounts of battery power when it is in use. The controller comes with a power switch that disconnects battery power when it is not in use. The switch is designed with a safety relay that prevents it from removing power to the controller while the generator is operating. If the switch is turned off while the engine is running it will continue operating until the engine shuts down and then the controller will power down.

This switch should be used when the generator is not going to be used over the course of several days and the generator is not connected to a battery charger.

A solar charger kit is the easiest way to always maintain the battery during storage in mobile applications. The supplied

# VOLTAGE REGULATOR

The following is a list of connections on the AVR. These have been factory set and other than voltage adjustment, should never be changed.

## AS440 AVR

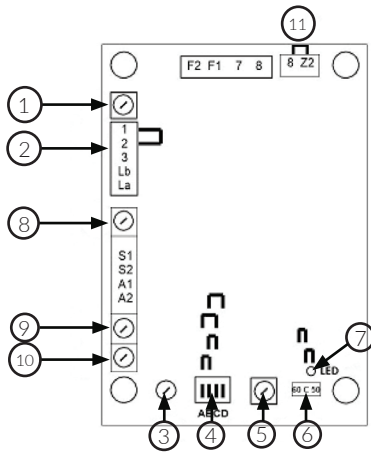

1. VOLTS - Adjust generator output voltage.  
Clockwise to increase voltage.
2. LINK: HAND TRIMMER  
1-2: NO TRIMMER  
NONE: TRIMMER FITTED  
Adjust alternator output voltage  
Clockwise to increase voltage by AVR voltage adjustment.
3. STABILITY - To prevent voltage hunting.  
Clockwise to increase dampening effect.
4. LINK: POWER: RESPONSE  
A-B: > 550kW : Fast  
B-C: 100-550kW : Fast  
A-C: < 100kW : Fast  
B-D: < 100kW : Slow
5. UFRO - Under Frequency Roll Off  
Clockwise decreases 'KNEE' point.
6. SWITCH - Select alternator frequency for UFRO  
SWITCH LEFT: 60Hz  
SWITCH RIGHT: 50Hz
7. LED Indicator Light - LED light on in UFRO or O/EXC condition.
8. DROOP - Adjust alternator droop to 5% at zero power factor.  
Clockwise to increase increase droop.
9. TRIM - Adjust analog input sensitivity.  
Clockwise to increase sensitivity.
10. O/EXC - Adjust over-excitation trip.  
Clockwise to increase trip voltage.
11. LINK: SUPPLY  
8-Z2: Main stator  
None: Auxiliary winding  
Select AVR supply source.

# OPERATING CONDITIONS

## NORMAL OPERATION

This generator-engine set needs load and should not idle for long periods of time.

If the generator application is for emergency standby the generator should be exercised at least monthly ideally under load. Load banking the generator at least annually will help keep the engine in good condition.

## HARSH ENVIRONMENTS OPERATIONS

Some applications require the generator to operate in harsh environments. One of the most common hazards are extremely dusty conditions. In harsh conditions it is often necessary to take additional steps to keep the equipment clean and operating at its peak. Maintenance intervals on lubricant and filter changes may need to be shortened. An oil quality testing program can also provide early warnings or oil degradation. Efforts may need to be made to reduce the amount of dust and debris entering the housing and generator components.

## COLD WEATHER OPERATIONS

The minimum starting temperature with block heater is -13°F.

The degree of fluidity of the engine oil may be reduced at low temperatures due to the separation of the paraffin. This results in the filters becoming clogged.

Oil companies must respect these standards, which provide for the distribution of fuels adapted to the climatic and geographical conditions in various countries.

This generator-engine set needs load and should not idle for long periods of time.

If the generator set will be run in extremely cold environments it may be beneficial to provide means to reduce air circulation to increase the temperature of the enclosure.

Inspect the hoses regularly during cold operation looking for signs of freezing. If the line freezes it will cause pressure to build in the crankcase and may cause an engine seal failure. If the engine operates below optimal temperatures for long periods of time damage may occur.

# MAINTENANCE

Reasonable care in preventative maintenance will ensure high reliability and a long life for the engine-generator set.

## WARNING

Place controller in manual mode, e-stop applied first. If an auto start signal comes on during maintenance, it may result in injury, death and equipment damage.

## CHANGING THE OIL

WINCO pipes the oil change to the outside for convenient maintenance.

Winco recommends our 5W-30 fully synthetic heavy duty engine oil to give you maximum cold weather protection while maintaining excellent performance in warmer weather. We have partnered with a national lubrication oil manufacturer to give you access to Winco private branded premium oil available at comparable prices to conventional oils. See your dealer for additional information.

## WARNING

Only change oil when the engine is not running and is at a low temperature in order to avoid the risk of burns.

1. Warm the engine to normal operating temperature. Then stop the engine.
2. Place a drip pan or suitable container for catching the oil. WINCO has supplied a valve on the skid frame to hook a customer supplied 5/8" hose to conveniently run the oil to the drip pan.
3. Drain the oil.
4. Once the oil has fully drained, close the valve.
5. Top-off through the filler port using lubricant oil with the suitable oil table in the LUBRICATION section of this manual.
6. Use the dip stick to ensure the level of oil does not exceed the "MAX" limit.
7. Insert the dipstick and close the lubricant oil cap.
8. Dispose of oil in accordance to local codes. DO NOT dispose or allow oil to seep into the ground or sewer systems, doing so will cause environmental damage.

## CHANGING OIL FILTER

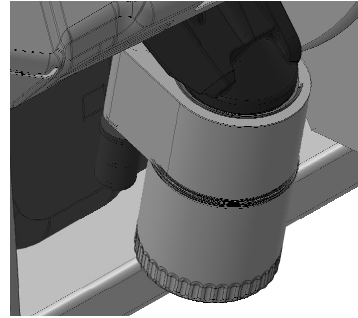

The filter must be replaced when the lubricant oil is changed.

Only use filters with a filtering degree equal to the original filter.

## WARNING

Only change oil when the engine is not running and is at a low temperature in order to avoid the risk of burns.

1. Use an oil filter wrench to unscrew and remove the oil filter. Ensure old o-ring is removed.
2. Lightly coat the gasket on the new oil filter with engine oil.
3. Install the new engine oil filter manually by screwing on new oil filter canister until sealing ring abuts the filter head and tighten a further 1/2 turn. Do NOT use a strap wrench or similar tool to tighten the filter canister.
4. Warm up the engine by running it for 5 minutes and check for any oil leaks.
5. Recheck the oil level using the dipstick.
6. Add engine oil to engine oil filler port as needed until the level is at the maximum line shown on the dipstick.

## FILLING COOLANT

## WARNING

Never remove the pressure cap while the engine is running or if cooling system is hot. Scalding coolant or steam can escape, which can cause serious burns.

## NOTICE

Never use a cold coolant mixture to top-up the radiator of a hot engine if the coolant level is very low; this could cause severe engine damage.

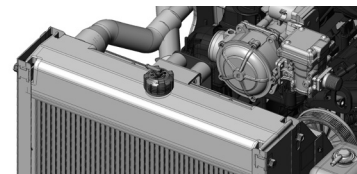

1. Engine should be cooled down to at least 110°F
2. Ensure the radiator plug located at the bottom of the radiator and the plug on the engine block are secure.
2. Turn the filler cap 90° counter-clockwise, pause to allow the pressure to drop. Remove the cap (1) and slowly pour the coolant into the radiator until it is even with the lip of the filler port.

Ensure no air bubbles develop.

3. Reinstall radiator cap.

## CHANGING COOLANT

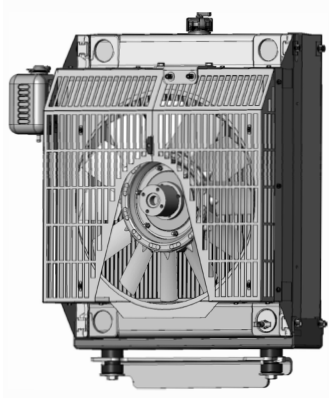

Engine coolant contaminated with rust or water scale reduces the cooling effect. Even when extended life engine coolant is properly mixed, the engine coolant gets contaminated as its ingredients deteriorate. Drain, flush and refill the cooling system with new coolant every 1000 hours or once a year, whichever comes first.

### WARNING

Only proceed when the engine is not running and is at a low temperature in order to avoid the risk of burns.

1. Loosen the cap on the radiator. Once all of the pressure is released, fully remove the cap.
2. Remove the drain plug at the bottom of the radiator and drain the coolant into an approved container. Reinstall plug.
3. Remove the coolant drain plug from the engine block.
4. After draining the engine coolant, flush the radiator and engine block with water to remove any rust, scale and contaminants. Then reinstall and tighten the drain plug.
5. Fill the coolant reservoir tank first. When the coolant is just over the fins in the radiator. Replace cap and securely tighten.
7. Fill the remaining amount of coolant needed in the radiator. Replace cap.
8. Run the engine to check for leaks.

## COOLANT FILL & BURP INSTRUCTIONS

1. Make sure engine is plumbed and all drains/petcocks are closed. Place towel or rag around radiator fill cap area to prevent spills.
2. Remove the hose cap and fill the radiator with coolant.



3. Once coolant starts to drip from the opening, replace the cap and secure it with its hose clamp.
4. Add more coolant mix into radiator until full.
5. Top off radiator to about halfway up the neck. Top off reservoir to fill line. Ensure cap is tightened securely.



7. Test run and inspect for any leaks/verify unit is not overheating.

## CLEANING RADIATOR

The surfaces of the radiator come into contact with the outside air and can be subject to deposits and impurities. Clean in accordance to the maintenance schedule with compressed air or steam.

1. Remove dirt or foreign material with a soft brush or cloth.

### NOTICE

Never use a cold coolant mixture to top-up the radiator of a hot engine if the coolant level is very low; this could cause serious engine damage.

## CHANGING AIR FILTER

The engine performance is adversely affected when the air cleaner element is clogged with dust.

### NOTICE

Never operate the engine with the air cleaner element removed. This may allow foreign material to enter the engine and damage it. Do NOT remove filter while engine is running.

1. Unlatch and remove the air cleaner cover.
2. Remove the element.

3. Clean inside the air cleaner body and cover.
4. Replace the element with a new one.
5. Reinstall the air cleaner cover .
6. Latch the air cleaner cover to the case.

## STORAGE

### PREPARING THE ENGINE FOR A LONG PERIOD OF INACTIVITY

In the case of a planned period of inactivity that lasts longer than one month, to prevent the interior parts of the engine and some components of the injection system from oxidizing, prepare the engine as follows:

#### ONE MONTH

1. While the engine is running, treat upper cylinders by spraying engine fogging agent into the air intake for about two minutes. Open throttle for short bursts of speed, shut off engine and allow it to come to a stop while continuing to spray into air intake.
2. Leave spark plugs in holes or seal spark plug holes with suitable threaded metal plugs and cover all openings into engine with dust-proof caps or shields.
3. If engine is less transmission, spray flywheel and ring gear with mixture of one part recommended engine oil, and one part Stoddard Solvent or equivalent.
4. Check coolant protection. Store indoors in dry area.

#### INFINITE PERIOD

1. Perform the next Preventive Maintenance procedure. For example, if there are 10 hours remaining before the 250 hour maintenance, you should do the maintenance before you place the engine in storage.
2. Drain crankcase completely and refill with recommended engine oil.
3. Run engine until completely out of fuel.
4. Check coolant protection
5. Disconnect and remove the battery.
6. Clean exterior surface of the engine.
7. Leave spark plugs in holes or seal spark plug holes with suitable threaded metal plugs.
8. Seal all openings in engine and accessories with non-hygroscopic material. Mask off all area to be used for electrical contacts.
9. Make sure all surfaces are dry, and then spray all taped openings, all engine accessories including ignition wiring, and all exterior surfaces of engine with Insulation Compound.

## RETURNING ENGINE TO SERVICE

1. Perform the Daily Checks.
2. The engine should be pre-oiled before startup. Crank the engine, leaving the fuel system shut off so the engine will not start, for 15 seconds. Then pause for 30 seconds. Repeat the procedure until you have cranked the engine for a total of one minute. This will circulate the oil in the engine's lubrication system.
3. Start the engine. Allow the engine to idle for approximately 15 minutes while you check for:
  - Proper oil pressure
  - Fuel, engine oil, or coolant leaks
  - Proper operation of the indicators and/or gauges.
4. Avoid prolonged operation at minimum or maximum engine speeds and loads for the remainder of the first hour of operation.

## AUTOMATIC TRANSFER SWITCH

For information on proper maintenance for your transfer switch, see the ATS manufacturer's operator's manual.

## ENGINE-GENERATOR SET

Service the engine in accordance with the engine manufacturer's manual provided with your new equipment. Routinely remove debris and dirt from around the inside generator enclosure. Ensure that the air intakes are free from leaves and other debris at all times.

Clean and inspect battery terminals at least twice a year. Also check the battery water level at least twice a year.

Other than keeping the generator clean and free of debris, there is no other routine or preventative maintenance required as long as the generator is run bi-weekly to keep it dry and in good working order.

## MAINTENANCE SCHEDULE

DAILY
Check Engine Oil Level/Replenish if Needed
Check Coolant Level/Replenish if Needed
Check for Fluid Leaks & Tightness of Clamps/hoses
Check for Loose Electrical Connections
Check Battery Connections for Corrosion
Check LPG System for Leaks
EVERY 50 HOURS OF OPERATION
Check Coolant Level/Replenish if Needed
Check for Fluid Leaks & Tightness of Clamps/hoses
Check for Loose Electrical Connections
Check LPG Tank Supply Level
EVERY 200 HOURS OF OPERATION
Clean Debris From Radiator Core
Inspect Drive Belt for Cracks, Breaks, Splits, Glazing
EVERY 400 HOURS OF OPERATION
Change Engine Oil and Filter
Inspect Breather Hose
Check Spark Plugs
Change Air Filter
Check Air-Induction for Leaks
Inspect PCV Valve
Check All Nuts & Bolts For Tightness
Change Engine Coolant
EVERY 3000 HOURS OF OPERATION
Replace Spark Plugs

\* There are additional maintenance items and explanations in the engine operator's manual. Read thoroughly before operating this unit.

## TROUBLESHOOTING TABLES

UNIT WILL NOT CRANK WHEN THE POWER FAILS	<ol style="list-style-type: none"> <li>Digital genset controller not in "AUTO"</li> <li>Transfer control switch not in "AUTOMATIC".</li> <li>Incorrect wiring between transfer switch and generator.</li> <li>Loose or dirty battery terminals.</li> <li>Defective engine control module.</li> <li>Defective starter.</li> <li>Defective start solenoid.</li> <li>Defective start/stop control in the transfer switch.</li> <li>ATS panel in fault from previous run cycle.</li> <li>Blown fuse on generator control panel.</li> </ol>
ENGINE WILL NOT CRANK USING START BUTTON ON THE GENERATOR	<ol style="list-style-type: none"> <li>Low or dead battery, must hold 12 Volts during cranking.</li> <li>Blown fuse on generator control panel.</li> <li>Loose or dirty battery terminals.</li> <li>Defective engine control module.</li> <li>Defective starter.</li> <li>Defective start solenoid.</li> <li>Locked up engine generator set.</li> </ol>
ENGINE WILL NOT COME UP TO SPEED AFTER IT STARTS	<ol style="list-style-type: none"> <li>Insufficient fuel volume getting to the unit.               <ol style="list-style-type: none"> <li>Fuel line too small.</li> <li>Low fuel pressure.</li> </ol> </li> <li>AC short circuit.</li> <li>Governor is defective.</li> </ol>
ENGINE CRANKS BUT WILL NOT START	<ol style="list-style-type: none"> <li>Improper fuel pressure being delivered to unit.</li> <li>Fuel supply shut-off.</li> <li>Fuel supply empty.</li> <li>Defective spark plug.</li> <li>Defective engine ignition module.</li> <li>Dirty air cleaner filter</li> <li>Defective fuel solenoid valve.</li> <li>Low voltage from battery to fuel solenoid, must hold 12 Volts during cranking.</li> <li>Defective fuel regulator.</li> <li>Defective starter/fuel solenoid relay(s).</li> </ol>
ENGINE START AND THEN STOPS - Alarm light comes on	<ol style="list-style-type: none"> <li>Engine is low on oil</li> <li>Engine has high water temperature.</li> <li>Engine has overspeed.</li> <li>Engine has gone into overcrank.</li> <li>No output from engine alternator to engage stop crank cycle.</li> <li>Generator is not operating at the correct speed.</li> </ol>
ATS PANEL WILL NOT TRANSFER TO EMERGENCY SUPPLY	<ol style="list-style-type: none"> <li>No AC generator out put from generator.</li> <li>See Automatic Transfer Switch Manual.</li> </ol>
ATS PANEL WILL NOT PULL IN ON NORMAL POWER	<ol style="list-style-type: none"> <li>See Automatic Transfer Switch Manual.</li> </ol>
NO AC OUTPUT FROM GENERATOR	<ol style="list-style-type: none"> <li>Defective diodes.</li> <li>Defective voltage regulator.</li> <li>Defective rotor.</li> <li>Defective stator.</li> <li>Defective exciter rotor.</li> <li>Defective exciter stator.</li> <li>AC short in the input leads.</li> <li>Defective/Open breaker.</li> <li>Wiring error.</li> </ol>

# AC WIRING

## SINGLE PHASE 120/240V

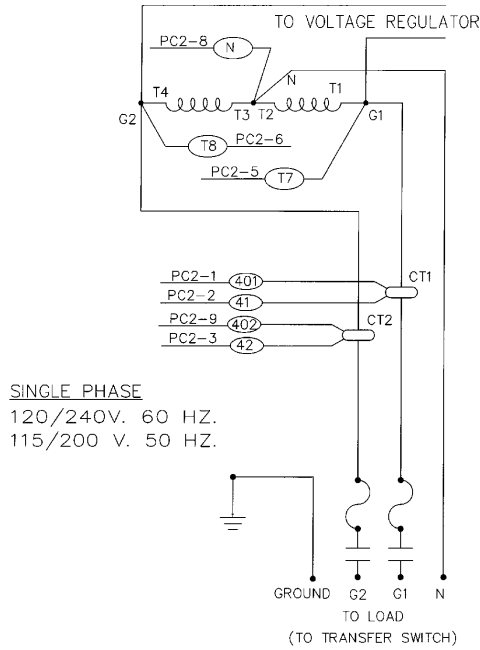

## THREE PHASE DELTA 120/240V

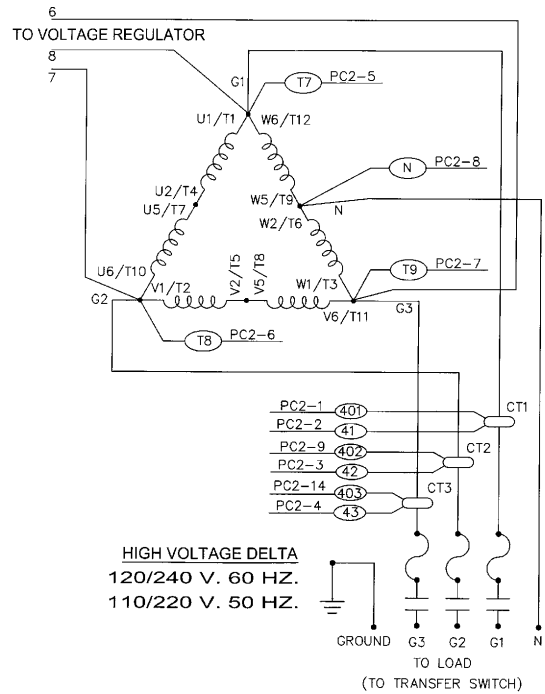

## THREE PHASE - LOW WYE 120/208V

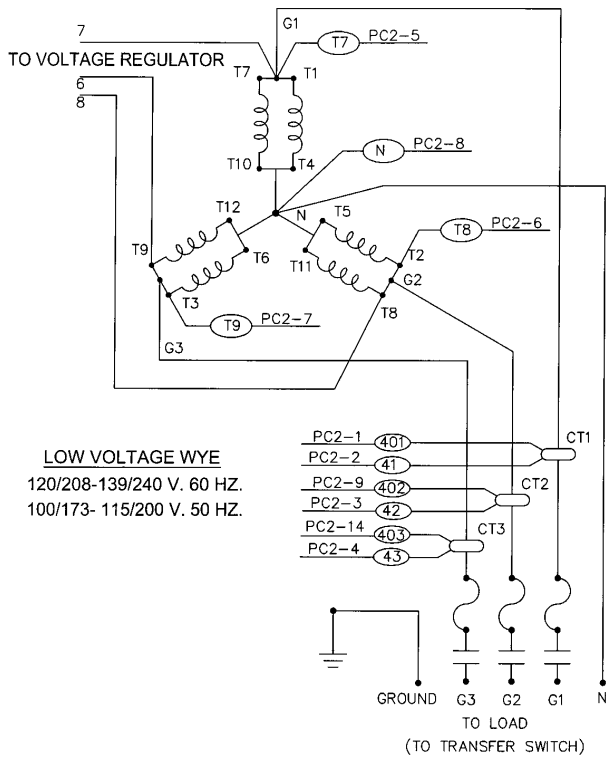

## THREE PHASE - HIGH WYE 277/480V

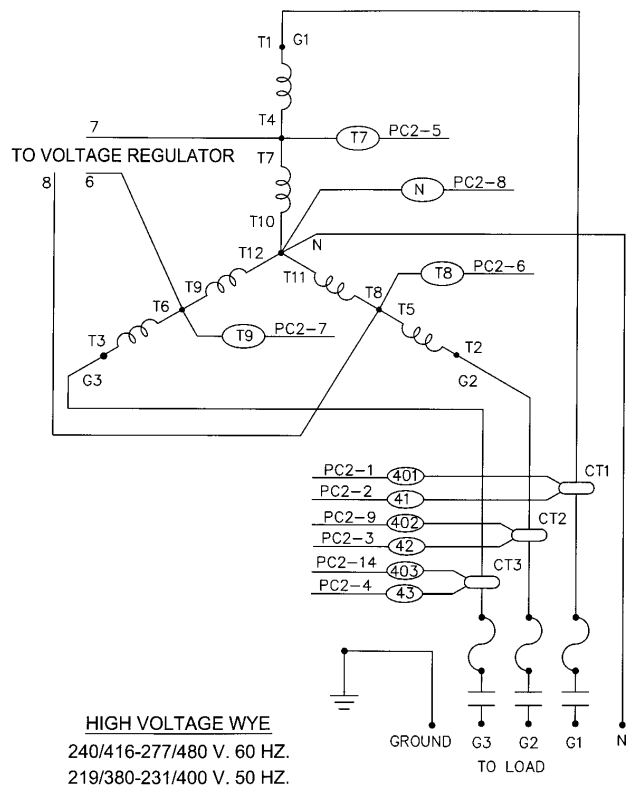

# DSE 7310 MKII WIRING DIAGRAM

LEGEND:  
 PS: POWER SWITCH  
 ESS: EMERGENCY STOP SWITCH  
 FSS: FUEL SELECTION SWITCH  
 VAR: VOLTAGE ADJUSTMENT RHEOSTAT

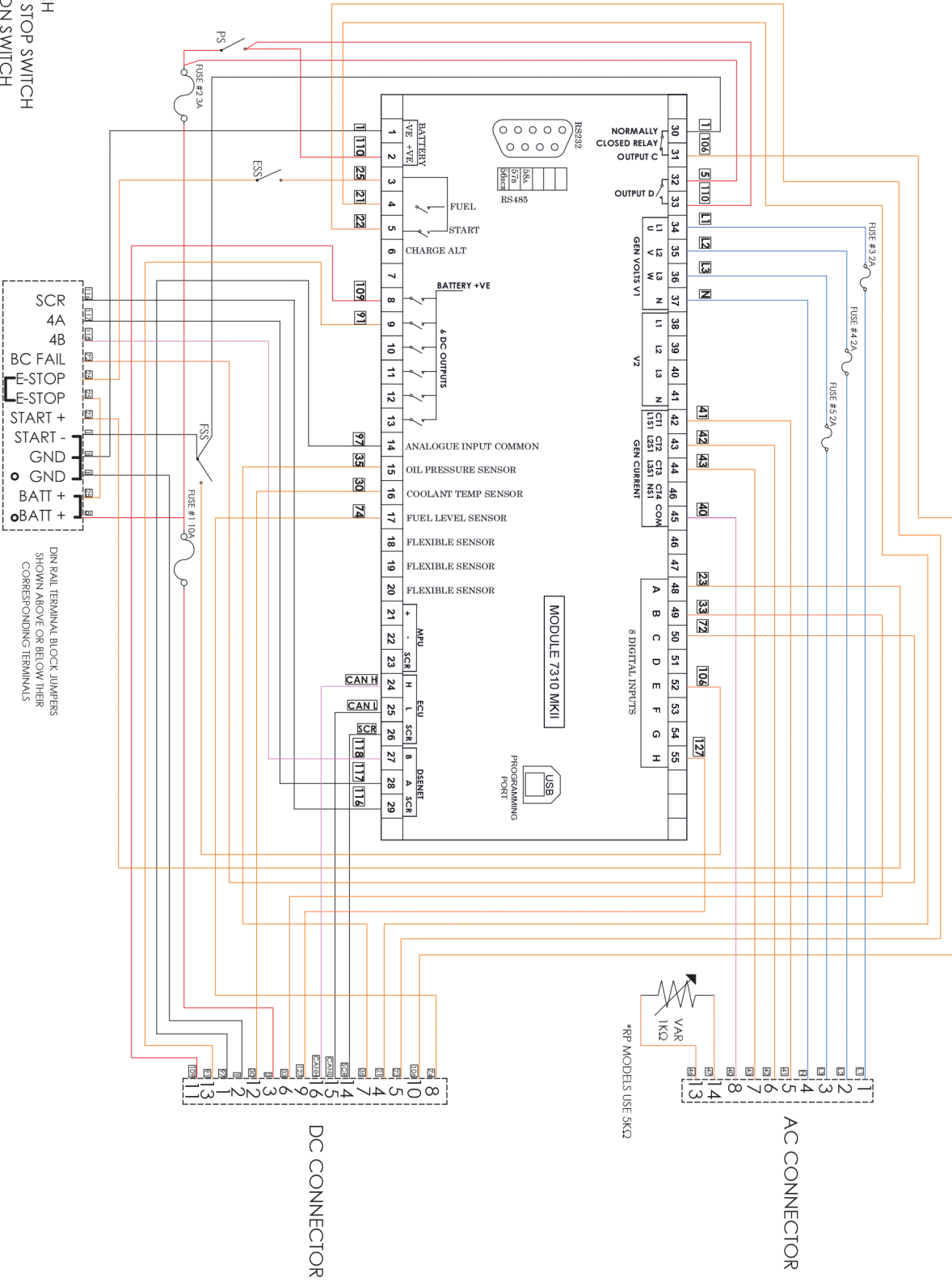

DIN TAIL TERMINAL BLOCK JUMPERS SHOWN ABOVE OR BELOW THEIR CORRESPONDING TERMINALS

# LIMITED WARRANTY

WINCO Incorporated warrants to the original purchaser for the warranty period that goods manufactured or supplied by it will be free from defects in workmanship and material, provided such goods are installed operated and maintained in accordance with WINCO written instructions.

WINCO's sole liability, and Purchaser's sole remedy for a failure under this warranty, shall be limited to the repair of the product. At WINCO's option, material found to be defective in material or workmanship under normal use and service will be repaired or replaced. For warranty service, contact a Winco Authorized Service Center within the warranty period from date of purchase.

\*NOTE: Units that are resold by original owner are not covered under this warranty. Any further warranty, whether expressed or implied, rests solely with the reseller.

## THERE IS NO OTHER EXPRESS WARRANTY.

To the extent permitted by law, any and all warranties, including those of merchantability and fitness for a particular purpose, are limited to the warranty period from date of purchase. In no event is WINCO liable for incidental or consequential damages.

Note: Some states do not allow limitation on the duration of implied warranty and some states do not allow the exclusion or limitation of incidental or consequential damages, so the above limitations may not apply in every instance. This warranty gives you specific legal rights which may vary from state to state.

## WINCO, INC. WARRANTY EFFECTIVE DATE

Air cooled units purchased for stock have 1 year to be sold. The warranty to the original retail customer commences on the date of sale of the product to them. All liquid cooled units have 180 days from the Winco invoice to submit a start up date. If no startup form is submitted, then warranty period starts on the Winco invoice date unit was sold.

Date of sale is defined as the day the customer takes delivery of the product. This warranty shall remain in effect to the original purchaser for the period stated on the sales literature. The warranty is not transferable and the retail customer must retain his original bill of sale as proof of purchase date.

WINCO, Inc. agrees to the following obligations during the warranty period:

1. To warrant any defect in material or workmanship of products sold under the WINCO and DYNA brand names in accordance with the warranty statements in the operator's manuals.
2. To reimburse authorized WINCO, Inc. Service Centers/Dealers for the cost of parts plus standard ground UPS shipping charges for all valid warranty repairs and to reimburse same said service centers/dealers for reasonable labor charges based on WINCO's current warranty labor reimbursement rate.
3. To furnish its authorized service centers/dealers with the necessary parts to make the repairs. WINCO Generator Warranty Periods & Restrictions

## WINCO GENERATOR WARRANTY PERIODS & RESTRICTIONS

Industrial Portables

WL Models - 3 Years, See Notes 1 & 2

W Models - 3 Years, See Notes 1, 2, & 5

DP Models - 3 Years, See Notes 1 & 2

HPS Models - 2 Years, Home Use ONLY; Commercial use\* is 90 Day Warranty, See Note 1

## EMERGEN-C (EC) SERIES

2 Years, See Note 1

## DE SERIES

1 Year/2000 hours, No Travel Time

## MOBILE DIESEL SERIES

1 Year/2000 hours, No Travel Time

## PTO SERIES

15kW & 10kW - 1 Year, Limited Farm Standby Only

25kW thru 165kW - 3 Years, Limited Farm Standby Only/Commercial use\* 1 Year

## TWO BEARING SERIES

1 Year, Bench Labor and Parts only

## GASEOUS/PACKAGED STANDBY SERIES (PSS)

Air-Cooled Models (PSS8, PSS12, & PSS20) - 2 Years/2000 Hours Standby Only See Notes 3 & 4 Prime Power use 1 Year/2000 Hours See Notes 3 & 4

Liquid-Cooled Models (PSS21 - PSS150) - 2 Years/2000 Hours Standby Only See Notes 3 & 4 Prime Power use 1 Year/2000 Hours See Notes 3 & 4

## DIESEL STANDBY SERIES (DR)

Liquid-Cooled Models (DR12 - DR600) - 2 Years/2000 Hours Standby Only See Notes 3 & 4

Prime Power use 1 Year/2000 Hours See Notes 3 & 4

Accessories (Installed on Generator or shipped loose)

1 Year from factory invoice or 2000 Hours (whichever occurs first)

## AUTOMATIC TRANSFER SWITCHES (ATS)

See ATS Manufacturer's Warranty

### NOTES

Note 1: First 2 years of warranty coverage includes Parts and Bench Labor Only, no travel time or labor allowance for removal or reinstallation of the product from its application.

Note 2: 3rd Year warranty coverage is parts only/no labor.

Note 3: Round trip mileage is limited to 200 miles per trip and a total of 2 trips per repair unless authorized in writing by the WINCO Service Dept.

Note 4: Mileage allow on permanently installed units only. Trailer mount units is bench labor only.

Note 5: W3000 is a 1 Year Warranty.

\*Commercial use is defined as Construction, Rental, Prime Power, or use in a business of any type including agricultural and hobby. Prime Power use is defined as any application where the generator set is being used 'off-grid' where there is no utility power present. Standby use is defined as an application where utility power is present -and- the generator set is used as emergency backup during utility power outages.

WINCO reserves the right to change or improve it's products without incurring any obligations to make such changes or improvements on products purchased previously.

### EXCLUSIONS:

WINCO does not warrant Engines. Engines are covered exclusively by the warranties of their respective manufacturers.

WINCO does not warrant Batteries, or Other Component Parts that are warranted by their respective manufacturers.

WINCO does not warrant modifications or alterations which were not made by WINCO, Inc.

WINCO does not warrant products which have been subjected to misuse and/or negligence or have been involved in an accident.

This warranty does not include travel time, mileage, or labor for removal or reinstallation of WINCO product from its application, unless specifically authorized.

### WHAT IS COVERED BY WARRANTY

1. Generator end including rotor, stator, end brackets, and bearing.
2. Control box including transformers, circuit breakers, wiring, resistors, and switches.
3. LP/NG fuel system including fuel solenoid, demand regulator, carburetor, and hoses.
4. Cradle assembly including cradle, cross member, and shock mounts that fail. Shock mounts damaged from rough handling are not covered.
5. Reasonable travel time for the PSS & DR series generators only, that are permanently installed.
6. Ground shipping charges for warranty parts, no premium service, domestic US shipments only.

### WHAT IS NOT COVERED BY WARRANTY

1. Products which have been subjected to alteration, modification, neglect or unauthorized repairs not approved in writing by Winco, Inc.
2. Products no longer owned by the original purchaser.
3. Products with shipping or freight damage. File a freight claim with the delivery carrier.
4. Products suffering normal wear, accidents, improper maintenance or improper protection in storage. Products damaged by rough handling, such as shock mounts on cradle assemblies.
5. Pressure or steam cleaning of products, cleaning of fuel system, or flushing of cooling system.
6. Replacement of filter, belts, antifreeze, or lubricants.
7. Electrical items, such as light bulbs, receptacles, spark plugs, or any items damaged by welding or jump starting.
8. Any repeat or shop come-back repairs resulting from poor service work or improper diagnosis and testing. Replacement of parts as a trial-and-error method of diagnosis will not be considered for warranty.
9. Replacement parts other than those sold by Winco, Inc.
10. Damage caused by fire, flood, lightning or any other natural disaster.
11. Damage caused by improper protection during installation, (i.e. not protecting contactor in the ATS panel and getting wire trimming or debris from drilling the box in the contactor coil or contacts.)
12. Damage caused by over loading of the generator and failure to adequately provide overload protection.
13. LP/NG fuel adjustments or conversion from one fuel to another.
14. Adjustment of any kind, all units are 100% load tested before shipping.
15. Any damage caused by the use of the equipment for purposes other than for which it was designed.
16. Engines - All engines used by Winco, Inc. are warranted by their respective manufacturer's.
17. Batteries - Must be returned to original battery manufacturer.
18. Damage caused by improper installation or failure to provide adequate ventilation.
19. Cosmetic repairs, such as repainting.
20. Freight charges for transportation to and from a Warranty Service Center.
21. Rental costs of renting replacement generators.
22. Travel time or service calls unless specifically authorized by Winco, Inc. in writing.

### GENERAL INFORMATION

The WINCO, Inc. Service Department is open from 7:30 AM to 4:30 PM Central Standard time.

It is located at 225 South Cordova Ave., Le Center, MN, 56057-1805.

Phone Numbers: Service Department - 507-357-6831 FAX Line - 507-357-4857. Email address is service@wincogen.com

The phone number to for the General Switchboard/Sales Department is 507-357-6821.

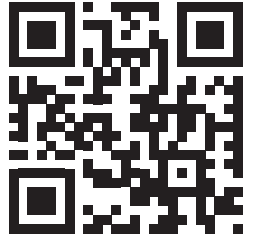

**WINCO<sup>®</sup>**  
**GENERATORS**  
 **AN AMERICAN COMPANY**

225 S. CORDOVA AVE • LE CENTER, MN 56057  
Sales: 507-357-6821 • sales@wincogen.com  
Service: 507-357-6831 • service@wincogen.com  
[www.wincogen.com](http://www.wincogen.com)

