

NPS

NEXT-GEN POWER SYSTEMS

OWNER'S GUIDE



Models NPS4500lp, NPS6000lp

Introduction

Welcome to N.P.S. Company, LLC's (NPS) Owner's Guide (Guide) for the NPS Generator Models (Generator). These Generators are designed with comfort and ease in mind. NPS is proud to provide these Generators to enhance your experience in the outdoors and the wild places of this planet.

NPS is dedicated to ensuring you will be able to focus on the adventures at hand and will have peace of mind knowing your recreational vehicle (RV) will have Generator power when and where you need it.

This Guide will provide you with an overview of the safety issues and precautions you will need to be aware of while operating, maintaining and storing the Generator with your RV. Safety is of utmost importance and failure to follow this Guide may result in performance degradation of the Generator and extreme bodily injury to the owner. The Safety section below is followed by information, photos and details specific to your Generator to help you make the most of your adventures and prolong the life of your unit.

This Guide should be used for NPS Generator Models NPS4500lp, NPS6000lp only.

A. Safety

A.1 Throughout this Guide, you will see several warnings repeated to alert the Generator owner or operator to existing and potential hazards. These warnings are in place to ensure the safety of the Generator owner or operator.

A.2 Safety is of utmost importance and failure to follow the procedures as set forth in this Guide could result in performance failure of the Generator and severe bodily injury or death to the owner or operator.

A.3 These warnings will include:



DANGER: Indicates an immediate hazard, which if not avoided, will result in death or extreme bodily injury to installer or operator.

WARNING

WARNING: Indicates a hazard level between caution and danger and indicates a hazardous situation, which if not avoided, could result in death or serious bodily injury to installer or operator.

CAUTION

CAUTION: Indicates a potential hazard, which if not avoided may result in minor or moderate bodily injury to installer or operator.

A.4 Other words requiring attention and/or action, as stated include:

HAZARD	MANDATORY ACTION
ALERT	SAFETY PROCEDURES
SAFETY INSTRUCTIONS	SAFETY SHUTDOWN PROCEDURES
PROHIBITION INFORMATION	ATTENTION

A. Safety

WARNING PROHIBITION

A.5 Do not attempt to service or repair Generator:

- Unless you are mechanically knowledgeable and experienced or are being supervised by a qualified technician
- When physically tired or mentally weary
- If alcohol has been consumed within previous twenty-four (24) hour period
- If drugs have been consumed or administered, including prescription drugs which in any way alter normal physical functioning or mental capacity with-in previous twenty-four (24) hour period
- While smoking
- If children or pets are in close proximity to service or maintenance area
- While wearing jewelry on hands, wrists or around neck
- While wearing loose clothing which could fall into or be caught by moving parts in, or around Generator
- While Generator is running

WARNING

MANDATORY ACTION

A.6 Required prior to commencement service or maintenance:

- Locate and keep multi-class ABC fire extinguishers within reach of RV and readily available at all times
- Determine, locate and wear personal protective equipment (PPE) necessary for Generator service and maintenance, including but not limited to safety glasses, as required by NPS
- Verify negative (-) battery cable is disconnected at the battery (or batteries), prior to performing maintenance. Always disconnect the negative (-) battery cable first and only reconnect it after maintenance or repairs have been fully completed to prevent unplanned starting or arcing while working on the Generator
- Locate and identify all moving parts including fans, belts, pulleys, hinged covers, etc., to raise awareness of potential hazard areas in and around the Generator
- When working in an enclosed space, locate and verify operational carbon monoxide and smoke detector(s) in the service area

A. Safety

WARNING

HAZARD ALERT

A.7 Gasoline is flammable and explosive:

- Keep multi-class ABC fire extinguisher(s) within reach and readily available throughout the service or maintenance process
- Do not smoke or permit others to smoke at or near repair or maintenance location
- Any rags soiled with gasoline or oil must be discarded in fireproof container
- Routinely check for leaks and collections of gasoline pooling in the service area
- Secure and shield fuel lines separately and away from electrical wiring and/or ignition wiring to prevent accidental fire and/or explosion
- Keep all ignition sources away from fuel lines including:
 - open flames
 - arc producing equipment
 - sparks
 - pilot lights
 - electrical switches



DANGER

Gasoline-powered engines and tools present a serious health hazard. They produce high concentrations of carbon monoxide (CO). CO is a poisonous gas that can cause illness, permanent neurological damage and death. CO is colorless, odorless, and non-irritating and therefore can overcome exposed persons without warning. CO can rapidly accumulate (even in areas appearing to be well ventilated).

A.8 Review [cdc.gov/niosh/topics/co/default.html](https://www.cdc.gov/niosh/topics/co/default.html) for additional precautions and recommendations regarding "Carbon Monoxide Hazards from Small Gasoline Powered Engines"

A.9 Read and understand the OSHA Fact Sheet and Quick Reference Sheet for Carbon Monoxide Poisoning

https://www.osha.gov/OshDoc/data_General_Facts/carbonmonoxide-factsheet.pdf

<https://www.osha.gov/Publications/3282-10N-05-English-07-18-2007.html>

A. Safety

- A.10** Failure to follow the service and maintenance procedures as set forth in this Owner's Guide may void NPS' Limited Warranty and result in death or extreme bodily harm to owner or operator
- A.11** Do not operate Generator in an enclosed space such as a garage or storage stall
- A.12** Ensure RV is equipped with working CO detector
- A.13** Verify CO and smoke detector(s) are functioning properly while the Generator is operating
- A.14** Inspect entire Exhaust Assembly and Exhaust Support Strap and verify fittings are tight and secure and pipe opening is free of debris or other obstructions at initial start-up and after every ten (10) hours of operation
- A.15** Inspect and ensure CO and/or smoke detectors are operating properly at every start-up and replace batteries at intervals recommended by CO detector manufacturer for RVs



DANGER

A.16 Generator Voltage Arc-Flash and Electrical Shock Hazard

MANDATORY ACTION: Prior to performing any work on the Generator, all electrical connections must be identified and designated as either energized or non-energized to all service team members. Verification of energized or non-energized connection(s) or surfaces must be constantly monitored by a qualified technician

- A.17** Test equipment shall be used to ensure that electrical parts and circuit elements have been de-energized prior to performance of any and all Generator service or maintenance
- A.18** Testing instruments and equipment shall be visually inspected for external defects or damage before being used to determine de-energization (29 CFR 1910.334(c)(2))

A. Safety

DANGER



A.19 Generator Voltage Arc Flash and Electrical Shock Hazard:

Prior to working on live electrical equipment:

- Disconnect shore power to RV
- Disconnect negative (-) terminal battery or batteries
- Remove any metal or conductive apparel. Articles of jewelry and clothing such as metal: watch bands, bracelets, rings, keychains, necklaces, ear or other metal piercings, metalized aprons, cloth with conductive thread, or metal headgear shall not be worn. (29 CFR 1910.333(c)(8))
- NPS recommends working on a dry non-conductive material
- Ensure clothes, hands and hair are dry

A.20 Condition specific PPE, including safety glasses, must be worn to protect eyes and face from electric arcs, flashes or from flying objects resulting from an electrical explosion

A.21 Use only tools with non-conductive and/or non-combustible covered handles

A.22 Electrical connections shall be made by a qualified person experienced and familiar with the construction and operation of electrical equipment and the hazards involved. Qualified persons are intended to be only those well acquainted with and thoroughly conversant in electric equipment and electrical hazards involved with work being performed

A.23 Review placard and warnings on Generator for amperage and voltage information to protect installers and operators from hazards which could cause injury due to electric shock, burns or failure of electrical components.

CAUTION

A.24 Visually inspect all Generator mounting components (Exhaust Assembly, Service Access Door, Fuel Connections, Electrical Connections, Remote Control Panel) every ten (10) hours of operation.

WARNING

A.25 NPS' Generator is not designed to be a primary source of power for life support systems or devices but can support temporary operating or charging of recreational or battery powered components.

B. Getting to know your Generator

B.1 NPS Generator Models NPS4500lp, NPS6000lp are designed with the following features and benefits:

- NPS 3 year/2,000-hour limited warranty
- Pure sine wave inverter technology providing clean, safe and stable power
- Enhanced fuel efficiency
- Patented, advanced cooling system
- Improved muffler design for even less noise
- Hand-held remote-start Keyfob
- Largest Network of Service Locations

B.2 NPS Generator(s) provides AC Power to applicable components

B.3 This Guide will walk you through the following features and attributes of the NPS Generator Models NPS4500lp, NPS6000lp, where they can be found, how they work, how to operate and when to service

- **NPS Generator** See [Exhibit 1](#)
- **Generator Components Located within Service Access Door** See [Exhibit 2](#)
- **Generator Exhaust Assembly** See [Exhibit 3](#)
- **Generator Base** See [Exhibit 4](#)
 - Location of Air Intake and Air Outflow
- **Generator Fuel Line and Vapor Purge Line** See [Exhibit 5](#) (applicable to non-powered RV installations)

WARNING

- **Never store anything underneath or around the bottom or front of the Generator. Lack of a proper ventilation parameter may cause the Generator to overheat and/or ignite tall grass, vegetation or other objects in proximity to the running Generator. This presents a fire hazard which could ignite from hot exhaust pipe assembly, fumes and vapors and result in death or extreme bodily harm to the Owner or Operator.**

WARNING

- **Maintain a proper ventilation parameter extending 914.4 mm or (3') in all directions from all manufacturer installed Generator components.**

B. Getting to know your Generator

B.3 (continued)

- **Pre-Start Check and Inspection**
- **Starting and Operating the Generator**
- **Maintenance Requirements**
- **Troubleshooting**
- **NPS' Limited Warranty**
- **Specifications**
- **Maintenance Record**

Exhibit 1 - NPS Generator



Exhibit 4 - Generator Base

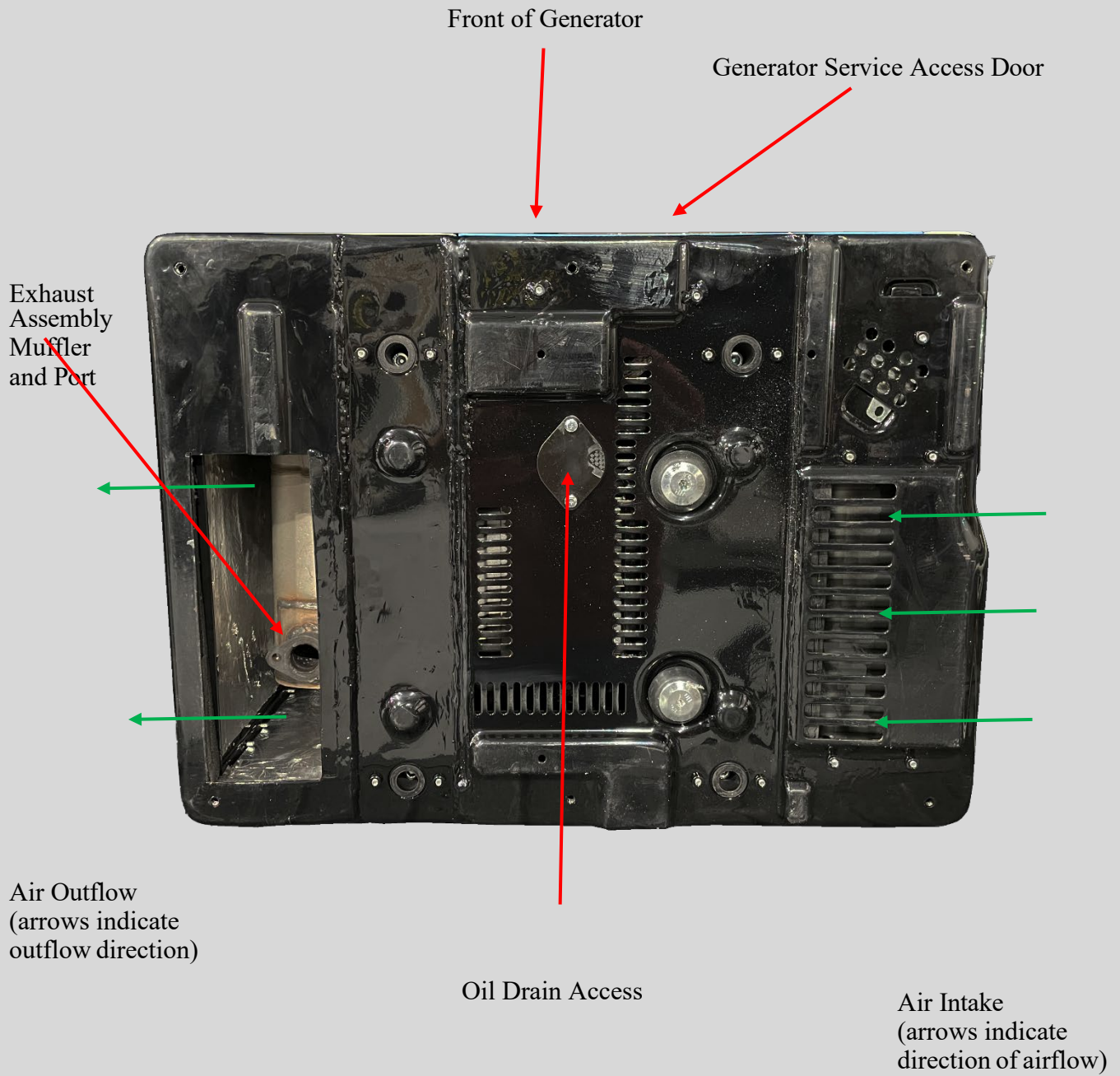
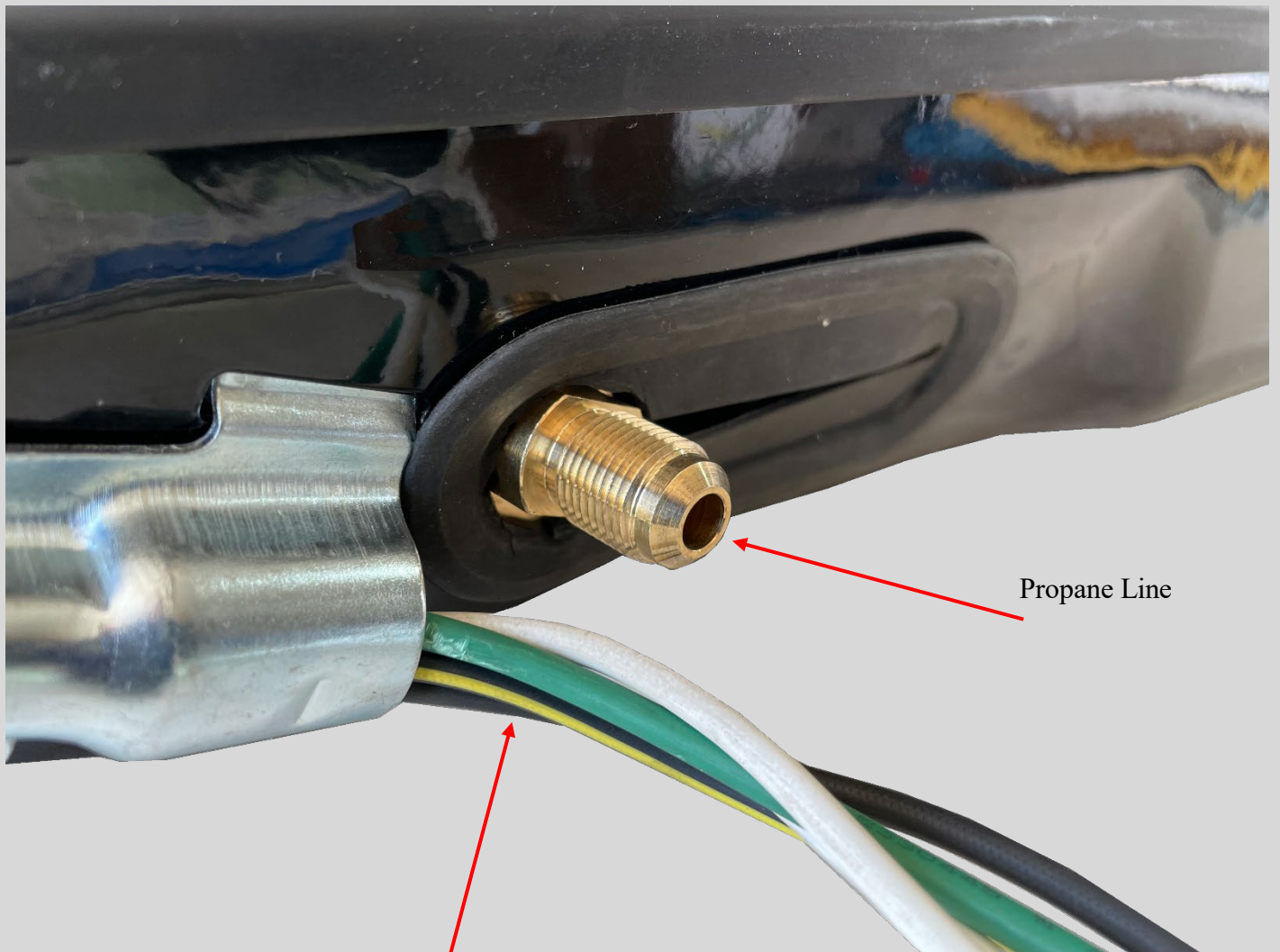

Exhibit 5 - Generator Fuel Line and Vapor Purge Line



Propane Line

Electrical Harness
Connecting Generator
to RV

C. Pre-Start Check and Inspection

C.1 Battery and Battery Connections

Verify there is sufficient battery voltage. Ensure all battery connections are clean of any acid build-up and battery cable nuts are securely fastened.

C.2 Locate, Open and Secure the RV Generator Compartment Door

C.3 Locate, Open and Remove Generator Service Access Door and set aside while performing remainder of Pre-Start Check and Inspection

C.4 Oil Level

- Ensure RV is on a level surface
- Remove the engine oil dipstick from engine
- Wipe off all excess oil from dipstick
- Re-insert engine oil dipstick without threading in dipstick
- Immediately remove and verify oil on dipstick is at FULL mark

C.5 Fuel Level and Connections

- **Never store anything underneath or around the bottom or front of the Generator. Lack of a proper ventilation parameter may cause the Generator to overheat and/or ignite tall grass, vegetation or other objects in proximity to the running Generator. This presents a fire hazard which could ignite from hot exhaust pipe assembly, fumes and vapors and result in death or extreme bodily harm to the Owner or Operator.**
- **Maintain a proper ventilation parameter extending 914.4 mm or (3') in all directions from all manufacturer installed Generator components.**
- Verify propane connection at Generator is secure. See [Exhibit 5](#)

C. Pre-Start Check and Inspection

C.6 Exhaust Assembly including Debris Screen See [Exhibit 3](#)

- Verify debris screen is intact
- Verify Support Strap is secure
- Verify Pipe Assembly is connected

C.7 Check Engine Air Filter Housing and Element

- Unlatch the Air Filter Housing cover
- Remove the Air Filter Element and inspect for dirt and debris
- Reinstall Air Filter Element
 - If dirt or debris is found, replace with new OEM AE002 Air Filter Element
- **When re-installing the Air Filter Housing, verify the cover seal is intact in its original location and the cover is latched correctly**

C.8 Ensure Overload Alarm and Oil Alert indicator lights on Generator Control Panel are off See [Exhibit 1](#)

C.9 Re-attach Generator Service Access door. See [Exhibit 1](#)

- Verify latches at the sides of the access door are both turned to "Closed"
- Close the RV Generator Compartment door and secure in place

D. Starting and Operating the Generator

D.1 Before Starting or Operating the Generator, familiarize yourself with the safety information set forth in the "A. Safety" portion of this Guide.

D.2 DANGER: Engine Exhaust

Gasoline-powered engines and tools present a serious health hazard. They produce high concentrations of carbon monoxide (CO). CO is a poisonous gas that can cause illness, permanent neurological damage and death. CO is colorless, odorless, and non-irritating and therefore can overcome exposed persons without warning. CO can rapidly accumulate (even in areas appearing to be well ventilated).

D.3 Prior to starting the Generator and upon initial arrival at chosen destination, perform an inspection of your RV's physical location as set forth in "D. Pre-Start Check and Inspection"

D.4 After completing the Pre-Start Check and Inspection, close the Generator Service Access Door. See [Exhibit 1](#)

- Turn latches on either side of the Service Access Door and verify both are secure.

D.5 Generator Cold Start would be first start of the day, a start after eight (8) hours of inactivity or a start in below freezing temperatures

- Depress and hold Stop/Prime switch for ten (10) seconds allowing the Generator to prime
- Then press and hold the Start switch until the Generator starts
- Remote Control Panel's light will blink and then remain steady once the Generator is running
- Allow the Generator to run a minimum of two (2) minutes before turning on devices or appliances connected to the Generator
- The process in **E.4** is exactly the same for the Remote Start/Stop Switch inside the RV and the Start/Stop Switch on the Generator Control Panel inside the Generator Service Access Door. See [Exhibit 6](#)

ATTENTION

D.6 At any time after initial Cold Start warm-up has been completed, starting and stopping the Generator may be performed by

- Start/Stop Switch on Remote Panel inside the RV. See [Exhibit 6](#)
- Start/Stop Switch inside the Generator Service Access Door. See [Exhibit 6](#)
- Integrated Pull-Start inside the Generator Service Access Door. See [Exhibit 6](#)

D. Starting and Operating the Generator

D.7 Wireless Hand-held Remote-Start Keyfob was created to conveniently allow you to start/stop your Generator from a distance of fifty (50) meters (164'). See [Exhibit 6](#)

- To start the Generator, press and hold the "START" button for more than one (1) second and then release the button
- To stop the Generator, press and hold the "STOP" button for more than one (1) second and then release the button

D.8 Using the Wireless Hand-held Remote-Start Keyfob for remote starting the Generator See [Exhibit 6](#)

The Keyfob you received with your RV will have its signals already matched to the Generator during installation. However, if you replace the Keyfob battery, are using a replacement Keyfob, or you lose your signal you will need to re-match the Generator and the Keyfob's wireless signals

- To match signals, connect the Generator with the RV battery source, turn the Master 12 Volt Power Switch, inside the Generator Service Access Door, to the "ON" position. See [Exhibit 2](#)
- Press the Signal Match Set Button on the Remote-Control Module and hold it for more than three (3) seconds until the Signal Match Indicator Light on the Remote-Control Module stays on constant
- Release the Signal Match Set Button and press the "STOP" button on the Keyfob (at this moment the Signal Match Indicator Light on the Remote-Control Module will blink one time and then stay on constant)
- Release the "STOP" button on the Keyfob and press the "START" button on the Keyfob (at this moment the Signal Match Indicator Light on the Remote-Control Module will blink one time and then stay on constant)
- Release the "START" button on the Keyfob, press and hold the Signal Match Set Button on the Remote-Control Module until the Signal Match Indicator Light on the Remote-Control Module is off
- Start the Generator by pressing "START" on the Keyfob, then stop the Generator by pressing "STOP" on the Keyfob to verify the signals have matched. If the match is not made, repeat the above procedure, until the Keyfob and Generator wireless signals are successfully matched

Exhibit 6 - Generator Start Options

Hand-held Remote Start/Stop Keyfob

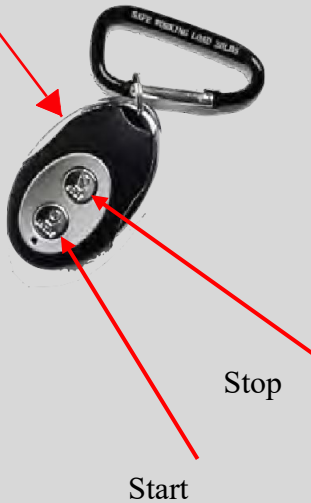

Remote Start/Stop Switch inside RV

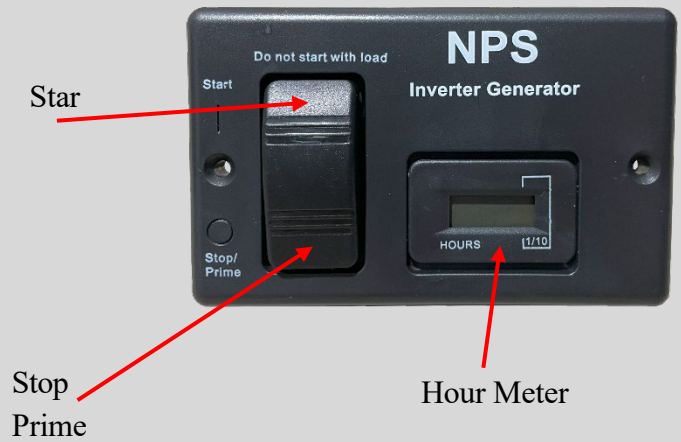

Start/Stop Switch inside Generator Service Access Door

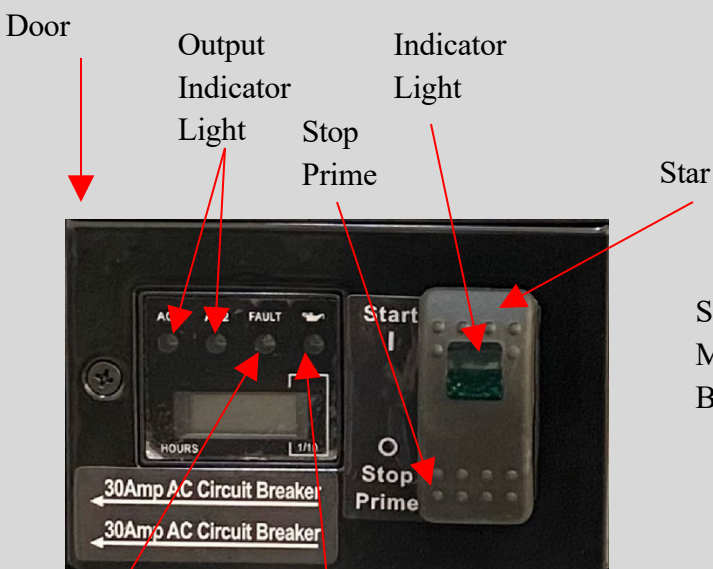

Fault Indicator Light
Overload Alarm

Fault Indicator Light - Oil Alert

Signal Match Indicator Light Remote Control Module

Star
Signal Match Set Button

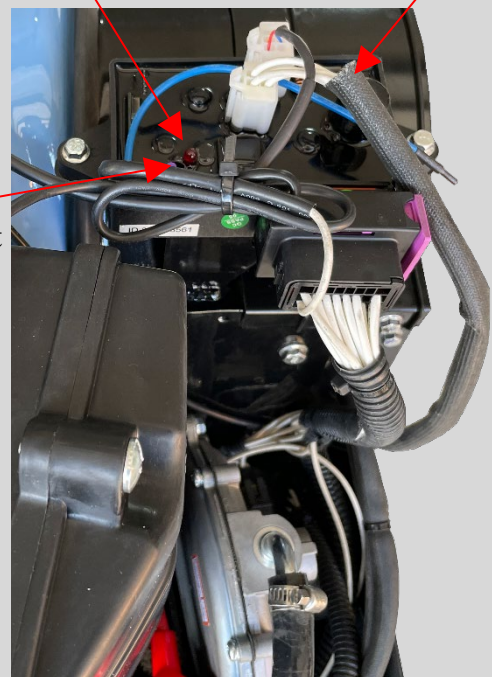

E. Maintenance Requirements

E.1 Oil.

- NPS recommends 10W-40
- Generator is equipped with break-in oil. Replace oil after first twenty (20) hours of operation and every one hundred (100) hour intervals thereafter or one (1) time every six (6) months, whichever comes first
- Oil should be checked and replaced more frequently when operated in hot weather or dusty climates
- Synthetic 10W-40 is permitted

E.2 Spark Plugs.

- Replace every 400 hours or sooner if engine performance drops off

E.3 Exhaust Assembly.

- Clean Spark Arrester and Muffler Screen at the end of the Exhaust Pipe with wire brush every forty (40) hours of operation or more frequently as needed based on visual inspections

E.4 Battery Connections

- Clean and check battery connections to ensure they are secure and free of corrosion at each initial use or monthly, whichever comes first

E.5 Air Filter Element

- Replace with new OEM AE002 Air Filter Element every one hundred forty (140) hours or more frequently when operated in dusty climates. See "D.7 - Pre-Start Check and Inspection" for a detailed replacement guide

F. Troubleshooting

Generator will not start:

F.1 Generator does not crank

- Inspect battery voltage and connection to ensure adequate voltage and secure connections
 - if you have a low battery or poor connections, Generator will not turn over
- Inspect the Master 12Volt Power "ON/OFF" Switch and verify it is in the "ON" position. See [Exhibit 2](#)
 - if battery voltage is adequate and Master 12Volt Power Switch is in the "ON" position
 - Attempt to start from another starting option
 - If generator still will not crank, manually turn Automatic Choke to "FULL" and use pull start to start the Generator. See [Exhibit 2](#)
 - If still won't start, contact your dealer or NPS directly

F.2 Generator cranks but does not run

- Inspect for adequate fuel
 - if fuel is depleted or shut off it will not start
- Inspect for spark
 - if your spark plug has carbon buildup, is fuel saturated or if ignition wire is damaged/disconnected, it will not start
- If generator has fuel and spark plug is intact and working properly and it still will not start, then contact your dealer or NPS directly

F.3 Generator is running but not powering my RV

- Check 30-amp breakers on the generator to see if they have tripped. If tripped, then reset
 - if they will not reset, then contact your dealer or NPS
- Check circuit breaker on Control Module (See [Exhibit 6](#)) to see if it has tripped. If tripped, then reset
 - if it will not reset, then contact your dealer or NPS
- Inspect the breakers and GFCI inside the RV to see if they have tripped. If tripped, then reset
 - if they will not reset or still will not power, then contact your dealer or NPS

NPS offers full support for service, warranty and technical assistance through www.NPSrvpower.com or 1-866-407-1727 during normal business hours (9:00 am - 5:00pm MST) if assistance is requested outside normal business hours, leave a message or send an email and a team member will assist you as soon as possible.

F. Troubleshooting

F.4 There are two Fault Indicator Lights on the Generator Control Panel: Overload Alarm Light and Oil Alert Light. See [Exhibit 2](#) and [Exhibit 6](#)

- Overload Alarm Light blinks rapidly when the Generator is less than five percent (5%) overloaded
 - Generator will continue running and outputting electricity
- Overload Alarm Light stays on continuously when the Generator is more than five percent (5%) overloaded
 - Generator will keep running but the Generator output will be cut off automatically within twenty (20) seconds
- Overload Alarm Light stays on when the Generator is faulty (i.e. short circuit, low voltage, over voltage, engine over speed, etc.)
 - Generator will keep running but the Generator output will be automatically cut off
- Oil Alert Light blinks when the oil level is too low. In this case, the engine will shut down automatically and the Oil Alert Light will remain illuminated.

NPS offers full support for service, warranty and technical assistance through www.NPSrvpower.com or 1-866-407-1727 during normal business hours (9:00 am-5:00pm (MST)) if assistance is requested outside normal business hours, leave a message or send an email and a team member will assist you as soon as possible.

F. Troubleshooting

F.5 Hand-held Remote-Start Keyfob is not working

- Verify the problem is not with the Generator by starting the Generator using another starting option
 - If Generator will start from another starting option but Hand-held Remote Start Keyfob still will not start or stop the Generator, then the Keyfob signal may be the problem
- Re-set Keyfob signal by performing a Signal Match
 - To match signals, connect the Generator with the RV battery source, turn the Master 12 Volt Power Switch, inside the Generator Service Access Door, to the "ON" position. See Exhibit 2
 - Press the Signal Match Set Button on the Remote-Control Module and hold it for more than three (3) seconds, until the Signal Match Indicator Light on the Remote-Control Module stays on constant
 - Release the Signal Match Set Button and press the "STOP" button on the Keyfob (at this moment, the Signal Match Indicator Light on the Remote-Control Module will blink one time and then stay on constant)
 - Release the "STOP" button on the Keyfob and press the "START" button on the Keyfob (at this moment, the Signal Match Indicator Light on the Remote-Control Module will blink one time and then stay on constant)
 - Release the "START" button on the Keyfob, press and hold the Signal Match Set Button on the Remote-Control Module until the Signal Match Indicator Light on the Remote-Control Module is off
 - Start the Generator by pressing "START" on the Keyfob, then stop the Generator by pressing "STOP" on the Keyfob to verify the signals have matched. If the match is not made, repeat the above procedure, until the Keyfob and Generator wireless signals are successfully matched
- If your Hand-held Remote-Start Keyfob still does not work, then contact your dealer or NPS

NPS offers full support for service, warranty and technical assistance through www.NPSrvpower.com or 1-866-407-1727 during normal business hours (9:00 am-5:00pm (MST)) if assistance is requested outside normal business hours, leave a message or send an email and a team member will assist you as soon as possible.

Exhibit 7 - AC Power and Fuel Connectors

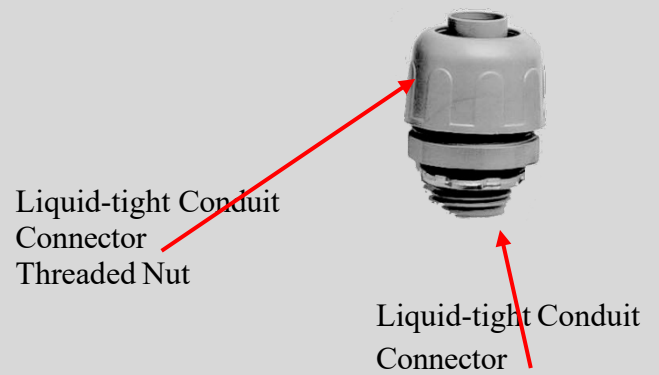
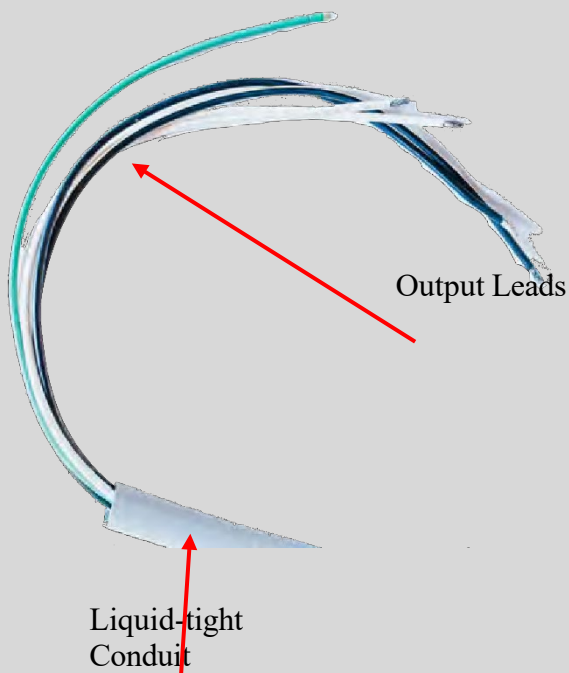
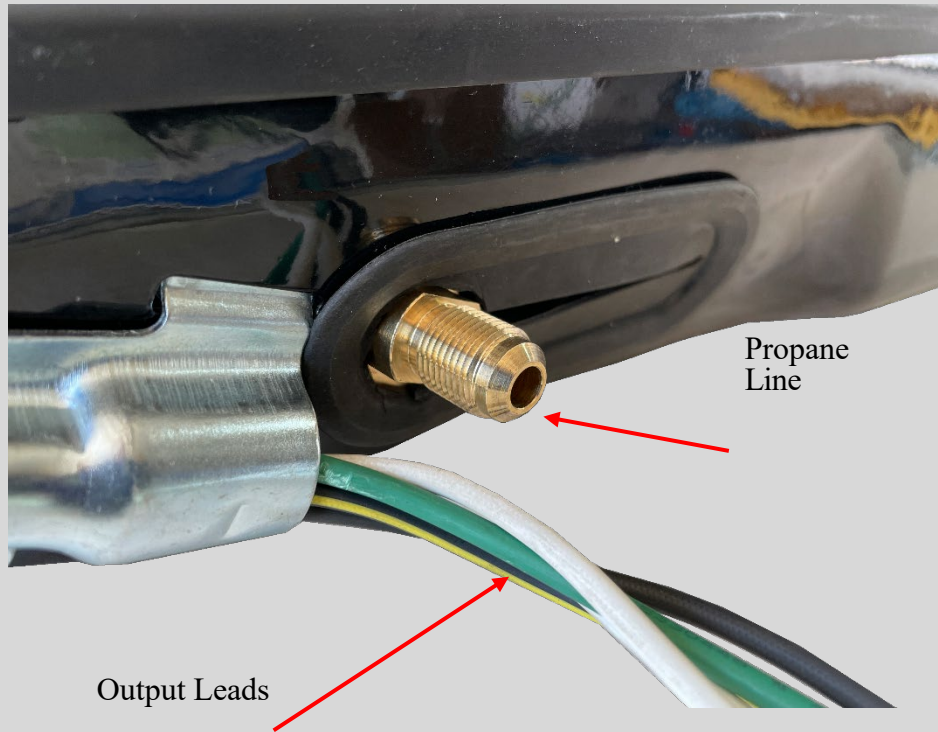
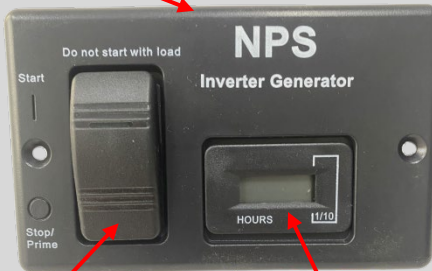

Exhibit 8 - Electrical Components

Remote Start Panel
(inside RV front)



Start/Stop/Prime
Switch

Generator
Hours

Remote
Start
Panel
(inside RV)

Hand-held
Remote
Start/Stop Keyfob
(back view with



Start
Butto

Stop
Butto



Start Button
Indicator

Hand-held
Remote
Start/Stop Keyfob
(front view)



Hand-held Remote
Start/Stop Keyfob
(inside view with
battery compartment
and screws)

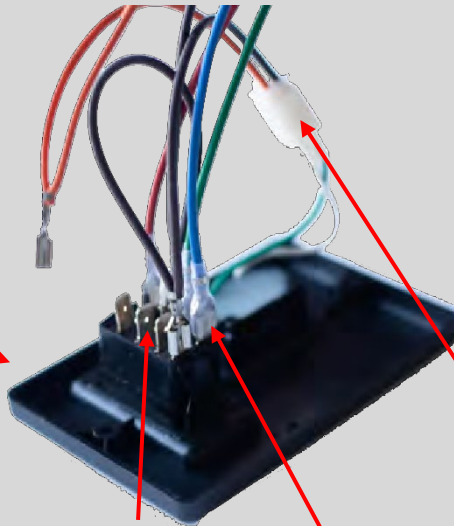

Remote Start
Panel to Wiring
Harness male
spade connectors

Generator Hours
Meter Connector
(lock-clip with green and
white wires) secured to
back of Remote Start Panel
(inside RV)

Wiring Harness for
Remote Start



Black female-end Connector
of Remote Start Panel
Wiring Harness for connection to
black male-end Connector
located inside Generator
Service Access Door

Wiring Harness Connector
to Generator Hours Meter
(orange and brown wires)
lock-clips to Generator Hours
Meter Connector attached to
Remote Start Panel (white and green

Wiring Harness to Remote
Start Panel female spade
connectors

Exhibit 9 - Wiring Harness - Remote Start Panel Connections

Top of Remote Start Panel (front)

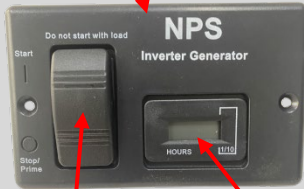

Start Stop/Prime Switch

Generator Hours Meter

Bottom of Remote Start Panel (front)

LCI One Control System (orange jumper)

Bottom of Remote Start Panel (back side)

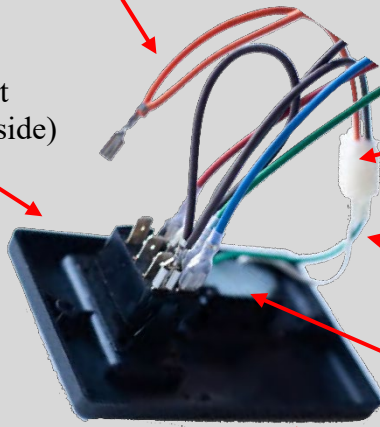

Remote Start Wiring Harness lock-clip (orange and brown wires)

Generator Hours Meter lock-clip (green and white wires, pre-installed on Remote Start Panel)

Generator Hours Meter Display

Start - Stop/Prime Switch spade connectors (diagram)

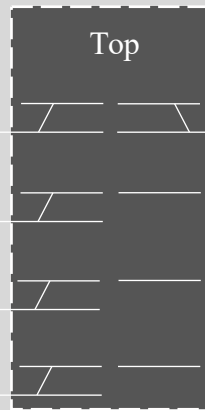

Blue

Green

Brown

Red

Brown Jumper

Top of Remote Start Panel (back side)

Exhibit 10 - Wiring Harness Connectors

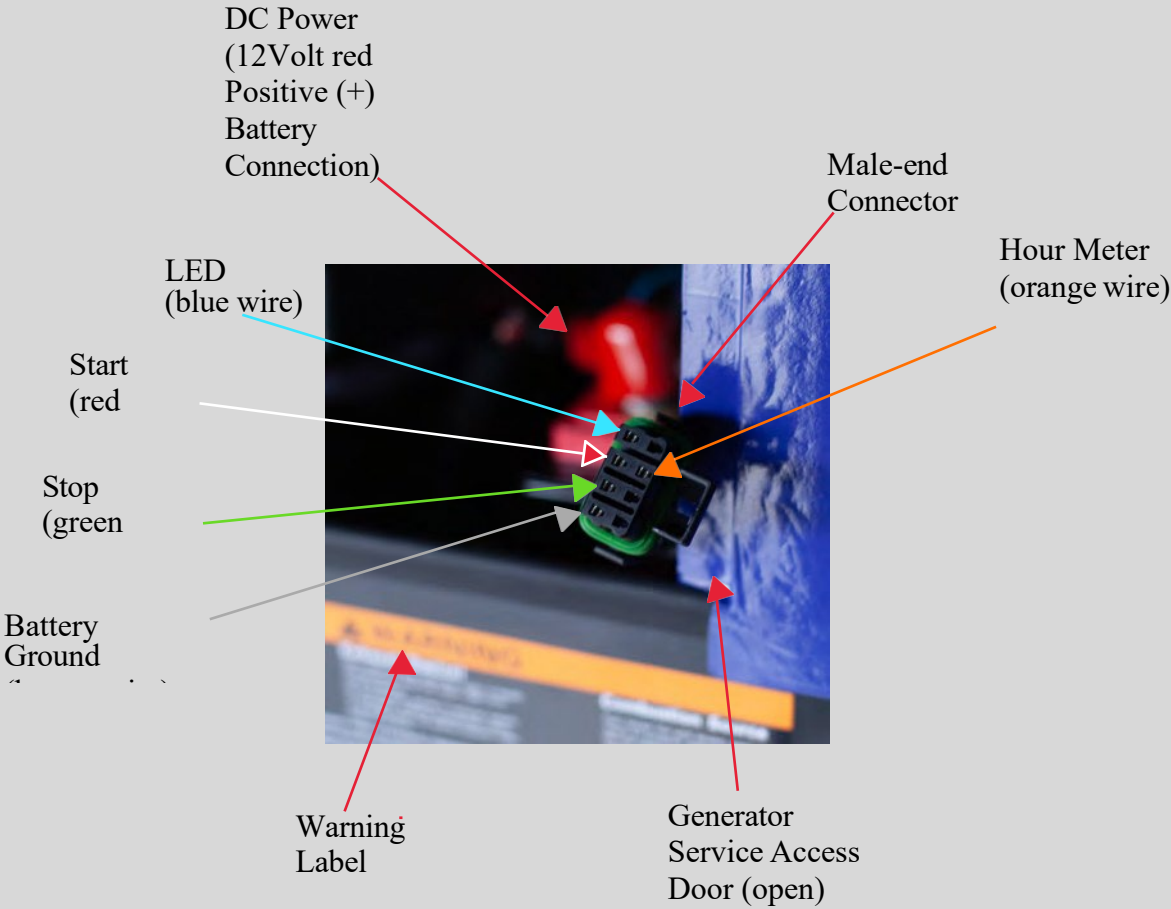
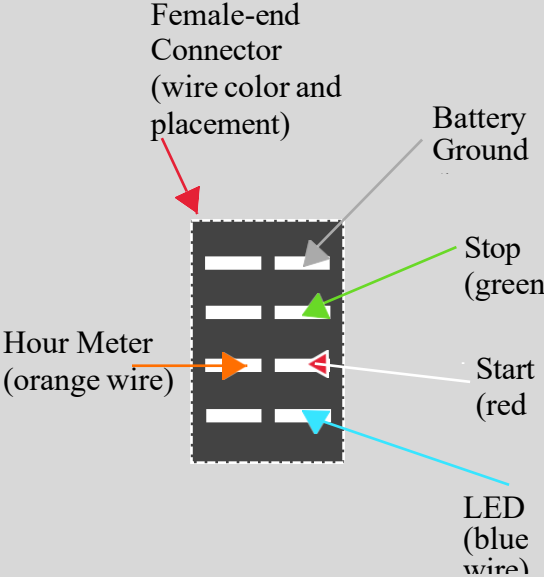

G. NPS Warranty

NPS offers full support for service, warranty and technical assistance through www.NPSrvpower.com or 1-866-407-1727 during normal business hours (9:00 am - 5:00pm MST) if assistance is requested outside normal business hours, leave a message or send an email and a team member will assist you as soon as possible.

When calling or contacting NPS, please have the following information ready and available:

- Date of Purchase
- Nature of the issue you are having, See "G. Troubleshooting" section of this Guide
- Generator Model Number
- Serial Number

You may refer to [Exhibit 2](#) of this Guide for assistance in locating both the Model and Serial numbers.

Specifications

Model:	NPS4500lp	NPS6000lp
Inverter/Voltage Regulator:	Proprietary Pure Sine Wave Inverter	
KVA Output:	4.5 KVA	5.5 KVA
Running Watts:	4,500 watts @ 3,600 RPM	5,500 watts @ 3,600 RPM
Max Amps:	37.5 Amps	50 Amps
Rated Current (Amps):	37.5 Amps	45.8 Amps
Max Output:	4,500 Watts	6,000 Watts
Rated Voltage:	120V	
Displacement:	357cc	
Engine Type:	Air-Cooled 4-Stroke OHV	
Engine:	NPS185	
Weight:	185 lbs. (83.91 KG)	
Length:	29.33 in. (745 mm.)	
Width:	21.46 in. (545 mm.)	
Height:	16.10 in. (409 mm.)	
Frequency:	60 Hz	

Specifications

Model:	NPS4500lp	NPS6000lp
Net Power Output:	8.4 HP (6.3 kW) @ 3,600 RPM	
Net Max Power:	10.2 HP (7.6 kW) @ 3,600 RPM	
Net Torque:	16.96 lbs.-ft @ 2,400 RPM	
Compression Ratio:	8.1-1	
Ignition System:	Non-contact Transistor Ignition (T.C.I.)	
Starting System:	Electric Start, Wireless Remote Start, Wired Remote Start (in the driving cab)	
Fuel Consumption: (Gal/Hr.)	.12 zero load; .29 half load; .58 full load	.12 zero load; .39 half load; .64 full load
Fuel Type:	Liquid Propane	
Pull Start:	No	
Remote Key Fob:	Yes	
Lubrication System:	Oil Splash	
Oil Capacity:	1.16 Quarts	

Owner's Manual & Safety
Instructions

SAVE THIS MANUAL

Keep this manual for safety warnings and precautions.



ENGINE DETAIL

⚠ DANGER

**Using an engine indoors
CAN KILL YOU IN MINUTES.**

Engine exhaust contains carbon monoxide. This is a poison you cannot see or smell

NEVER use inside a home or garage, EVEN IF doors and windows are open.

ONLY USE OUTSIDE and far away from windows, doors, and vents.

⚠ WARNING

Read this manual before using this product.
Failure to do so can result in serious injury.
SAVE THIS MANUAL

Visit our website at: <http://www.npsrvpower.com>





Call our support team at: (866) 407-1727 Email at: npsclaims@npsrvpower.com





SPECIFICATIONS

Displacement		357cc
Engine Type		Horizontal Single Cylinder 4-stroke OHV
Fuel Delivery		Liquid Propane
Cooling System		Forced air cooled
Fuel	Type	87+ octane stabilizer treated unleaded gasoline
Engine Oil	Type SAE	10W-40
	Capacity	1.15 qt
Bore x stroke		85x63mm
Compression Ratio		8.1:1
Rotation viewed from PTO (Power Takeoff – the output shaft)		Counterclockwise
Spark Plug	Type	NGK BPR4ES
	Gap	.028-.031
Speed	Idle	Variable

The emissions control system for this engine is warranted for standards set by the U.S. Environmental Protections Agency. For warranty information, refer to the past pages of this manual.

WARNING SYMBOLS AND DEFINITIONS

	This is the safety alert symbol. It is used to alert you to potential personal injury hazards. Obey all safety messages that follow this symbol to avoid possible injury or death.
	Indicates a hazardous situation which, if not avoided, will result in death or serious injury.
	Indicates a hazardous situation which, if not avoided, could result in death or serious injury.
	Indicates a hazardous situation which, if not avoided, could result in minor or moderate injury.

Symbol	Property or Statement
RPM	Revolutions Per Minute
HP	Horsepower
	WARNING marking concerning Risk of Eye Injury. Wear ANSI-approved safety goggles with side shields
	WARNING marking concerning Risk of Hearing Loss. Wear hearing protection.
	WARNING marking concerning Risk of Respiratory Injury. Operate engine OUTSIDE and far away from windows, doors, and vents.
	WARNING marking concerning Risk of Fire while handling fuel. Do not smoke while handling fuel.
	WARNING marking concerning Risk of Fire. Do not refuel while operating. Keep flammable objects away from engine.

IMPORTANT SAFETY INSTRUCTIONS



WARNING! Read all instructions. Failure to follow all instructions listed below may result in fire, serious injury and/or DEATH. The warnings and precautions discussed in this manual cannot cover all possible conditions and situations that may occur. It must be understood by the operator that common sense and caution are factors which cannot be built into this product, but must be supplied by the operator.

SAVE THESE INSTRUCTIONS!

SET UP PRECAUTIONS

1. Gasoline fuel and fumes are flammable, and potentially explosive. Use proper fuel storage and handling procedures. Do not store fuel or other flammable materials nearby.
2. Have multiple ABC class fire extinguishers nearby.
3. Operation of this equipment may create sparks that can start fires around dry vegetation.
 - i. A spark arrestor may be required.
 - ii. The operator should contact local fire agencies for laws or regulations relating to fire prevention requirements.
4. Set up and use only on a flat, level, well-ventilated surface.
5. Wear ANSI-approved safety goggles, heavy-duty work gloves, and dust mask/respirator during set up.
6. Use only lubricants and fuel recommended in the Specifications chart of this manual.

OPERATING PRECAUTIONS

1. **CARBON MONOXIDE HAZARD** Using an engine indoors **CAN KILL YOU IN MINUTES**.
 - a. Engine exhaust contains carbon monoxide.
 - b. This is a poison you cannot see or smell.
 - c. **NEVER** use inside a home or garage, **EVEN IF** doors and windows are open.
 - d. Only use **OUTSIDE** and far away from windows, doors, and vents.
2. Keep children away from the equipment, especially while it is operating.
3. Keep all spectators at least six feet from the Engine during operation.
4. **Fire Hazard!** Do not fill gas tank while engine is running.
5. Do not operate if gasoline has been spilled.
6. Clean spilled gasoline before starting engine.
7. Do not operate near pilot light or open flame.
8. Do not touch engine during use. Let engine cool down after use.
9. Never store fuel or other flammable materials near the engine.
10. Only use a suitable means of transport and lifting devices with sufficient weight bearing capacity when transporting the engine.
11. Secure the engine on transport vehicles to prevent it from

- rolling, slipping, and tilting.
12. Industrial applications must follow OSHA requirements.
 13. Do not leave the engine unattended when it is running.
Turn off the engine (and remove safety keys, if available) before leaving the work area.
 14. The engine can produce high noise levels.
 - a. Prolonged exposure to noise levels above 85 dBA is hazardous to hearing.
 - b. Wear ear protection when operating the engine or when working nearby while it is operating.
 15. Wear ANSI-approved safety glasses and hearing protection during use.
 16. People with pacemakers should consult their physician(s) before use.
 - a. Electromagnetic fields in close proximity to a heart pacemaker could cause pacemaker interference or pacemaker failure.
 - b. Caution is necessary when near the engine's magneto or recoil starter.
 17. Use only accessories that are recommended by NPS llc. for your model.
 - a. Accessories that may be suitable for one piece of equipment may become hazardous when used on another piece of equipment.

OPERATING PRECAUTIONS (continued)

18. Do not operate in explosive atmospheres, such as in the presence of flammable liquids, gases, or dust.
 - a. Gasoline-powered engines may ignite the dust or fumes.
19. Stay alert, watch what you are doing and use common sense when operating this engine.
 - a. Do not use while tired or under the influence of drugs, alcohol or medication.
20. Dress properly.
 - a. Do not wear loose clothing or jewelry.
 - b. Keep hair, clothing and gloves away from moving parts.
 - c. Loose clothes, jewelry or long hair can be caught in moving parts.
21. Parts, especially exhaust system components, get very hot during use.
 - a. Stay clear of hot parts.
22. Do not cover the engine during operation.

23. Always keep the engine and surrounding area clean.
24. Do not smoke, or allow sparks, flames, or other sources of ignition around the equipment, especially when re-fueling.

OPERATING PRECAUTIONS

1. Before service, maintenance, or cleaning:
 - a. Turn the master switch to its "OFF" position.
 - b. Allow the engine to completely cool.
 - c. Then, remove the spark plug cap from the spark plug.
2. Keep all safety guards in place and in proper working order.
 - a. Safety guards include muffler, air cleaner, mechanical guards, and heat shields, among other guards.
3. Do not alter or adjust any part of the equipment or its engine that is sealed by the manufacturer or distributor.
 - a. Only a qualified service technician may adjust parts that may increase or decrease governed engine speed.
4. Wear ANSI-approved safety goggles, heavy-duty work gloves, and dust mask/respirator during service.
5. Maintain labels and nameplates on the equipment.
 - a. These carry important information.
 - b. If unreadable or missing, contact NPS llc for a replacement.
6. Have the equipment serviced by a qualified repairperson using only identical replacement parts.
 - a. This will ensure that the safety of the equipment is maintained.
 - b. Do not attempt any service or maintenance procedures not explained in this manual or any procedures that you are uncertain about your ability to perform safely or correctly.
7. Store equipment out of the reach of children.
8. Follow scheduled engine and equipment maintenance.

OPERATION

 Read the ENTIRE IMPORTANT SAFETY INFORMATION section at the beginning of this manual including all text under subheadings therein before set up or use of this product.

Pre-Start Checks

Inspect engine and equipment looking for damaged, loose, and missing parts before set up and starting. If any problems are found, do not use equipment until fixed properly.

Checking and Filling Engine Oil

NOTICE: Your warranty is VOID if the engine's crankcase is not properly filled with oil before each use. Before each use, check the oil level.

Engine will not start with low or no engine oil.

1. Make sure the engine is stopped and is level.
2. Turn off the main power to the engine.
3. Clean the top of the dipstick and the area around it.
4. Remove the dipstick by turning it counterclockwise, and wipe it off with a clean, lint-free rag.
5. Reinsert the dipstick without threading it in and remove it to check the oil level.
 - a. The oil level should be up to the full level.
 - b. If the oil is at, or below, the low mark, add the appropriate type of oil until the oil level is at the proper level.
 - c. SAE 10W-40 synthetic or conventional oil is permitted for general use.
6. Thread the dipstick back in clockwise.
 - a. Do not overtighten.

NOTICE: Do not run the engine with too little oil. The engine will shut off if engine oil is too low.

Starting the Engine

Before starting the engine:

1. Follow the Set Up instructions in the equipment manual to prepare the equipment.
2. Inspect the equipment and engine.
3. Fill the engine with the proper amount and type of both unleaded gasoline and oil.
4. Read the Equipment Operation section in the equipment manual.

Start the engine:

1. Press the STOP button for 5 seconds.
2. Press the START button until engine starts.

NOTE: Allow the engine to run for 30 seconds with no load after each start-up so that the engine can stabilize.

Stopping the Engine

To stop the engine in an emergency, turn the master switch OFF Under normal conditions, use the following procedure:

1. Remove the load from the engine if possible.
2. Press the STOP button until the engine stops.

WARNING

TO PREVENT SERIOUS INJURY FROM ACCIDENTAL STARTING:

Turn the Main Power Switch of the equipment to its OFF position, wait for the engine to cool, and disconnect the spark plug cap before performing any inspection, maintenance, or cleaning procedures.

TO PREVENT SERIOUS INJURY FROM EQUIPMENT FAILURE:

Do not use damaged equipment. If abnormal noise, vibration, or excess smoking occurs, have the problem corrected before further use.

Follow all service instructions in this manual. The engine may fail critically if not serviced properly.

 Many maintenance procedures, including any not detailed in this manual, will need to be performed by a qualified technician for safety. If you have any doubts about your ability to safely service the equipment or engine, have a qualified technician service the equipment instead.

Cleaning, Maintenance, and Lubrication Schedule

Note: This maintenance schedule is intended solely as a general guide. If performance decreases or if equipment operates unusually, check systems immediately. The maintenance needs of each piece of equipment will differ depending on factors such as duty cycle, temperature, air quality, fuel quality, and other factors.

Note: The following procedures are in addition to the regular checks and maintenance explained as part of the regular operation of the engine and equipment.

Procedure	Before Each Use	Monthly or every 20 hr. of use	Every 3 mo. or 50 hr. of use	Every 6 mo. or every 140 hr. of use	Yearly or every 500 hr. of use	Every 2 years
Brush off outside of engine	✓	✓	✓	✓	✓	✓
Check engine oil level	✓	✓	✓	✓	✓	✓
Check air filter				✓	✓	✓
Change engine oil		New break-in		✓	✓	✓
Clean/replace air				✓*	✓	✓

filter						
Check and clean spark plug				✓	✓	✓

- Service more frequently when used in dusty areas.

Engine Oil Change

⚠ CAUTION Oil is very hot during operation and can cause burns. Wait for the engine to cool before changing oil.

1. Make sure engine is stopped and is level.
2. Turn Main Power Switch is OFF
3. Place a drain pan (not included) underneath the crankcase's drain plug.
4. Remove the drain plug and, if possible, tilt the crankcase slightly to help drain the oil out
5. Recycle used oil
6. Replace the drain plug and tighten it.
7. Clean the top of the dipstick and the area around it.
8. Remove the dipstick by turning it counterclockwise, and wipe it off with a clean, lint-free rag.
9. Add the appropriate type of oil until the oil level is at the full level. SAE 10W-40 is recommended for general use.
10. Thread the dipstick back in clockwise.

NOTICE: Do not run the engine with too little oil. The engine will shut off if engine oil is too low.

Air Filter Maintenance

1. Remove the air cleaner cover and the air filter element.
2. Replace with a new OEM AE002 Air Filter Element every 140 hours, or more frequently when operated in dusty climates.

Spark Plug Maintenance

1. Disconnect spark plug cap from end of plug.
2. Clean out debris from around spark plug.
3. Using a spark plug wrench, remove the spark plug.
4. Inspect the spark plug.
 - a. If the electrode is oily, clean it using a clean, dry rag.
 - b. If the electrode has deposits on it, or the plug is damaged, replace it with a new spark plug.
5. When installing a new spark plug, adjust the plugs gap according to the specifications chart.
6. Install the new spark plug, or cleaned spark plug, into the engine and tighten ½ turn after spark plug contacts cylinder head, then reattach the spark plug cap.

Storage

1. Cleaning.
 - a. Wait for engine to cool, then clean Engine with a dry cloth. NOTICE: DO NOT CLEAN WITH WATER. The water will gradually enter the Engine and cause rust damage.
 - b. Apply a thin coat of rust preventative oil to all metal parts.
2. Fuel.
 - a. To protect the fuel tank during storage, fill the tank with gasoline that has been treated with a fuel stabilizer additive following the fuel stabilizer manufacturer's recommendations for use.
3. Lubrication.
 - a. Change engine oil.
 - b. Clean out area around spark plug.
4. Storage area
 - a. Cover and store in a dry, level, well-ventilated area out of reach of children.
 - b. Storage should be away from ignition sources such as water heaters, clothes dryers, and furnaces.
5. During extended storage periods.
 - a. Start engine every 3 months and let run for 15-20 minutes or the warranty is VOID
6. After storage.
 - a. Before starting the engine during or after storage, keep in mind that untreated gasoline will deteriorate quickly.
 - b. Drain the fuel tank and change to fresh fuel if untreated gasoline has been sitting for a month, if treated gasoline has been sitting beyond the fuel stabilizer's recommended time period, or if the engine does not start.

Warranty

NPS offers full support for service, warranty and technical assistance through

www.NPSrvpower.com or

1-866-407-1727

during normal business hours (9:00 am - 5:00pm MST) if assistance is requested outside normal business hours, leave a message or send an email and a team member will assist you as soon as possible. When calling or contacting NPS, please have the following information ready and available:

1. Date of Purchase
2. Nature of the issue you are having,
3. Generator Model Number
4. Serial Number

NPS
NEXT-GEN POWER SYSTEMS