

# NPS

*NEXT-GEN POWER SYSTEMS*

## INSTALLATION GUIDE



**Models NPS4500efi, NPS6000efi**

# Introduction

---

Welcome to N.P.S. Company, LLC's (NPS) Installation Guide (Guide) for the Generator Model NPS4500efi, NPS6000efi (Generator). Our Generators are designed with comfort and ease in mind. NPS is proud to provide these Generators to enhance your experience in the outdoors and the wild places of this planet.

This Guide should be used for NPS Generator Models NPS4500efi, NPS6000efi only. Safety is of utmost importance and failure to follow this Guide could result in performance degradation of the Generator and extreme bodily injury or harm to the installer or operator.

All aspects of the installation should adhere to all applicable local, state and federal construction and installation requirements. If there is a conflict between the requirements of this Guide and local, state and federal requirements, the most stringent installation requirement shall apply.

NPS' technical support is available 9:00 a.m. to 5:00 p.m. (MST) at (866) 407-1727 and [www.npsrvpower.com](http://www.npsrvpower.com), to respond to any questions or concerns you may have regarding a NPS Generator installation.

# A. Overview

---

**A.1** This Guide should be used as a reference for all NPS4500efi, NPS6000efi Generator installations in Recreational Vehicles (RV).

**A.2** All areas and actions of the installation should adhere to each applicable local, state and federal construction and installation requirement. If there is a conflict between the requirements in this Guide and local, state or federal requirements the most stringent installation requirement will apply.

**A.3** Bookmarks will serve as the table of contents and may be used to assist with quick reference and electronic navigation. This Guide will provide detailed safety and installation guidance for both the NPS4500efi, NPS6000efi Generators in the following order:

## A.4 Introduction

- A. Overview
- B. Safety
- C. Generator Selection
- D. Installation Kit
- E. Generator Install Location
- F. Preparation, Clearances, Ventilation and Air Ducting
- G. Generator Installation and Mounting
- H. Exhaust Kit Installation
- I. Electrical Connection
- J. Fuel Connection
- K. Installation Overview
- L. Initial Start-up
- M. Troubleshooting
- N. Exhibit List
- O. Quick Reference: Contacts and Warranty

**MANDATORY  
ACTION**

**A.5** Installers are required to read and understand this entire Guide prior to proceeding with any action or activity related to the installation. Failure to do so may void NPS' Limited Warranty and may result in extreme bodily injury or death to the installer or operator.

**A.6 This Installation Guide supersedes all previously distributed NPS guides or manuals**

## B. Safety

---

**B.1** Throughout the Guide you will see several warnings repeated to alert the Generator installer to existing and potential hazards. These warnings are in place to ensure the safety of the Generator installer before, during and upon completion of Generator installation.

**B.2** Safety is of utmost importance and failure to follow the procedures as set forth in this Guide may result in performance failure of the Generator and severe bodily injury or death to the installer or operator.

**B.3** These warnings are:



**DANGER:** Indicates an immediate hazard, which if not avoided, will result in death or extreme bodily injury to installer or operator.



**WARNING:** Indicates a hazard level between caution and danger and indicates a hazardous situation, which if not avoided, could result in death or serious bodily injury to installer or operator.



**CAUTION:** Indicates a potential hazard, which if not avoided may result in minor or moderate bodily injury to installer or operator.

**B.4** Other Safety words requiring attention and/or action, as stated include:

- ALERT
- ATTENTION
- HAZARD
- INFORMATION
- MANDATORY ACTION
- PROHIBITION
- SHUTDOWN PROCEDURES

## B. Safety

---

### WARNING

#### B.5 DO NOT attempt to install or work on Generator:

### PROHIBITION

- Unless experienced and trained to perform required tasks
- When physically tired or mentally weary
- If alcohol has been consumed within previous twenty-four hour period
- If drugs have been consumed or administered, including prescription drugs, which in any way alter normal physical functioning or mental capacity
- While smoking
- If children or pets are in close proximity to installation area
- While wearing jewelry on hands, wrists, ears or around neck
- While wearing loose clothing which could fall into or be caught by moving parts in, or around Generator

### WARNING

#### B.6 REQUIRED prior to commencement of installation:

### MANDATORY ACTION

- Locate and keep multi-class ABC fire extinguishers within reach of installer and readily available throughout the installation
- Determine, locate and wear personal protective equipment (PPE) necessary for Generator install including but not limited to safety glasses, as required by the Manufacturer and compliant with your installation site internal procedures and processes
- Verify negative (-) battery cable is disconnected at battery, and 12 volt master switch is off prior to installation or performing maintenance, to prevent unplanned starting or arcing while working on the Generator
- Prior to installation or performance of any maintenance, always disconnect negative (-) battery cable first and only reconnect it after installation or maintenance has been fully completed
- Locate and identify all moving parts including fans, belts, pulleys, hinged covers, etc., to raise installer awareness of potential hazard areas in and around Generator
- Locate and verify CO/smoke detector is installed and is working properly in your immediate installation site or workspace
- Prior to installation locate the ECI Fuel Registration tag in the Generator installation area, call 800 phone number listed on the tag and verify the RV has a ECI Fuel System approved and certified for the NPS Generator. See [Exhibit 1](#).

## B. Safety

---



**MANDATORY  
ACTION**

### **B.7 DANGER! GASOLINE and VAPORS are FLAMMABLE and EXPLOSIVE**

- Keep multi-class ABC fire extinguishers within reach of installer and readily available throughout the installation
- Do not smoke or permit others to smoke at or near install location
- All rags soiled with gasoline or oil must be discarded in a fire-proof container
- Routinely check for leaks and collections of gasoline pooling in install area
- Secure and shield fuel lines separately and away from electrical wiring to prevent accidental ignition
- Keep all ignition sources away from fuel lines and including:
  - open flames
  - arc producing equipment
  - sparks
  - pilot lights
  - electrical switches



### **B.8 DANGER! CO POISONING and ENGINE EXHAUST INHALATION**

Gasoline-powered engines and tools present a serious health hazard. They produce high concentrations of CO and other toxic substances in their associated fumes and vapors which, when inhaled in high concentrations, may result in death or extreme bodily injury to the installer. CO is a poisonous, toxic, odorless, colorless and non-irritating gas, which is given off whenever fuel or other carbon-based materials are burned.

CO can rapidly accumulate (even in areas appearing to be well ventilated), and can overcome exposed persons without warning. Unsafe levels of CO may exist near running gas generators or near air outflow, venting or exhaust from Generator. CO is a poisonous gas that can cause illness, permanent neurological damage and death. Breathing CO may produce headache, dizziness, vomiting and nausea and, in high concentrations, unconsciousness or death. Exposure to CO at moderate to high levels, over long periods of time, as also been linked with increased risk of heart disease.

- Review [cdc.gov/niosh/topics/co/default.html](https://www.cdc.gov/niosh/topics/co/default.html) for additional precautions and recommendations regarding "Carbon Monoxide Hazards from Small Gasoline Powered Engines"
- Read and understand the OSHA Fact Sheet and Quick Reference Sheet for Carbon Monoxide Poisoning

[https://www.osha.gov/OshDoc/data\\_General\\_Facts/carbonmonoxide-factsheet.pdf](https://www.osha.gov/OshDoc/data_General_Facts/carbonmonoxide-factsheet.pdf)

<https://www.osha.gov/Publications/3282-10N-05-English-07-18-2007.html>

## B. Safety

---



MANDATORY  
ACTION  
ACTION

### B.8 DANGER! CO POISONING and ENGINE EXHAUST INHALATION (continued)

- Exhaust Kit must be installed according to procedures set forth in this Guide. Failure to follow installation procedures may void NPS' Limited Warranty and result in death or extreme bodily harm to installer or operator.
- Do not operate Generator in an enclosed space such as a garage or storage stall.
- Ensure immediate installation area is equipped with a working CO/smoke detector.
  - Verify detector is functioning properly prior to commencing with Generator installation.
- Ensure RV is equipped with working CO/smoke detector.
  - Verify detector is functioning properly prior to spending time in RV while Generator is operating.
- Inspect exhaust pipe and verify fittings are tight and secure and pipe opening is free of debris or other obstructions at initial start-up and after every ten (10) hours of operation.
- Inspect and ensure CO/smoke detectors are operating properly at every start-up and replace batteries at intervals recommended by CO/smoke detector manufacturer



MANDATORY  
ACTION

WARNING

ALERT

### B.9 DANGER! Generator Voltage: ELECTRICAL ARC, SHOCK and FIRE HAZARD

#### Prior to performing any work on the Generator:

- Identify and designate all electrical connections as either energized or non-energized to all service team members.
- Verification of energized or non-energized connection(s) or surfaces must be constantly monitored by a qualified technician throughout the Generator installation.
- Test equipment shall be used to ensure that electrical parts and circuit elements have been de-energized prior to performance of any and all Generator installation segments.
- Testing instruments and equipment shall be visually inspected for external defects or damage before being used to determine de-energization (29 CFR 1910.334(c)(2))

## B. Safety

### **B.10 DANGER! Generator Voltage: ELECTRICAL ARC, SHOCK and FIRE HAZARD**

#### **Prior to working on live or potentially live electrical equipment:**

- Disconnect shore power to RV
- Disconnect negative (-) terminal battery or batteries
- Remove any metal or conductive apparel. Articles of jewelry and clothing such as metal: watch bands, bracelets, rings, keychains, necklaces, ear or other metal piercings, metalized aprons, cloth with conductive thread, or metal headgear shall not be worn. (29 CFR 1910.333(c)(8))
- NPS recommends working on dry non-conductive material
- Ensure clothes, hands and hair are dry
- Condition specific PPE, including safety glasses, must be worn to protect eyes and face from electric arcs, flashes or from flying objects resulting from an electrical explosion
- Use only tools with non-conductive and/or non-combustible covered handles
- Electrical connections shall be made by a qualified person experienced and familiar with construction and operation of electrical equipment and the hazards involved. Qualified persons are intended to be only those well acquainted with and thoroughly conversant in electric equipment and electrical hazards involved with work being performed
- Review placard and warnings on Generator for amperage and voltage information to protect installers and operators from hazards which could cause injury due to electric shock, burns or failure of electrical components
- Visually inspect all Generator mounting components (Exhaust Assembly, Service Access Door, Fuel Connections, Electrical Connections, Remote Control Panel) and every ten (10) hours of operation thereafter
- **NPS' Generator is not designed to be a primary source of power for life support systems or devices but can support temporary operating or charging of recreational or battery powered components**

## B. Safety

---

### ATTENTION

#### B.11 Safety Regulations

**NPS recommends all installers be familiar with and understand the following regulations before commencing installation:**

- 29 CFR 1910 Occupational Safety and Health Standards
- 29 CFR 1910.333 Subpart S: Electrical: Selection and use of work practices
  - <https://www.osha.gov/laws-regs/regulations/standardnumber/1910/1910.333>
- CDC - Carbon Monoxide Poisoning
  - <https://ephtracking.cdc.gov/showCoRisk.action#:~:text=Breathing%20CO%20can%20cause%20headache,increased%20risk%20of%20heart%20disease.>
- NEC 70/NFPA 70
  - <https://www.nfpa.org/codes-and-standards/all-codes-and-standards/list-of-codes-and-standards/detail?code=70>
- NFPA 1192 Standard On Recreational Vehicles, 2018
  - <https://www.nfpa.org/codes-and-standards/all-codes-and-standards/list-of-codes-and-standards/detail?code=1192>
- OSHA Publication for Internal Combustion Engines as Ignition Sources
  - <https://www.osha.gov/Publications/osha3589.html>
- OSHA Publications for CO
  - [https://www.osha.gov/OshDoc/data\\_General\\_Facts/carbonmonoxide-factsheet.pdf](https://www.osha.gov/OshDoc/data_General_Facts/carbonmonoxide-factsheet.pdf)
  - [https://www.osha.gov/OshDoc/data\\_Hurricane\\_Facts/carbon\\_monoxide.pdf](https://www.osha.gov/OshDoc/data_Hurricane_Facts/carbon_monoxide.pdf)
- RVIA/ANSI Standards
  - <https://www.rvia.org/standards-regulations/standards-compliance/association-and-ansi-standards>

## **B. Safety**

---

### **B.11 Safety Certifications**

**NPS Model NPS4500efi, NPS6000efi Generator have met the requirements and maintain the following certifications:**

- CARB
  - EO U-U-017-0346 New Off-Road Small Spark Ignition Engines at or Below 19 Kilowatts
- EPA Certification No. LYMXS.4032EK
- TEI Certification Product Listing No. 19J01

## Exhibit 1 - ECI Fuel System Tag

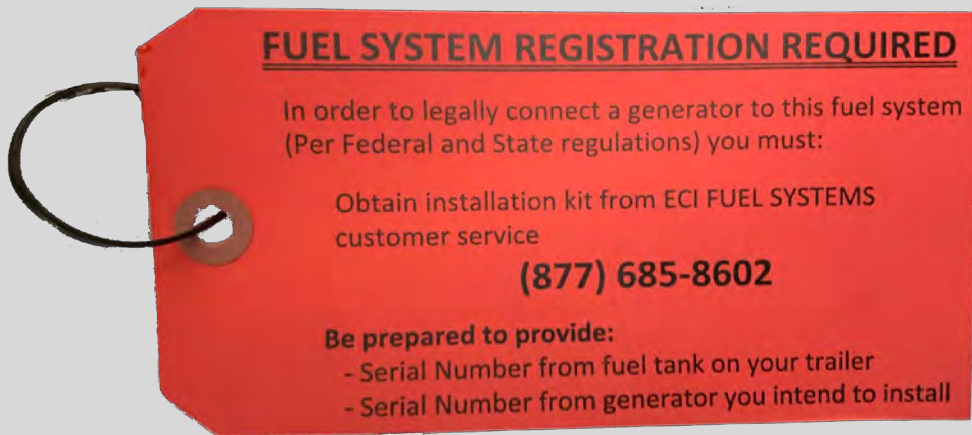

## C. Generator Selection

**C.1** Throughout the Guide you will see several warnings repeated to alert the Generator installer to existing and potential hazards. These warnings are in place to ensure the safety of the Generator installer before, during and upon completion of installation.

**C.2** NPS offers the Generator Model NPS4500efi, NPS6000efi. Installers shall install the NPS Generator model appropriate for the application. See [Exhibit 2](#).

## Exhibit 2 - NPS Generator



### Exhibit 3 - Generator Components Located within Service Access Door

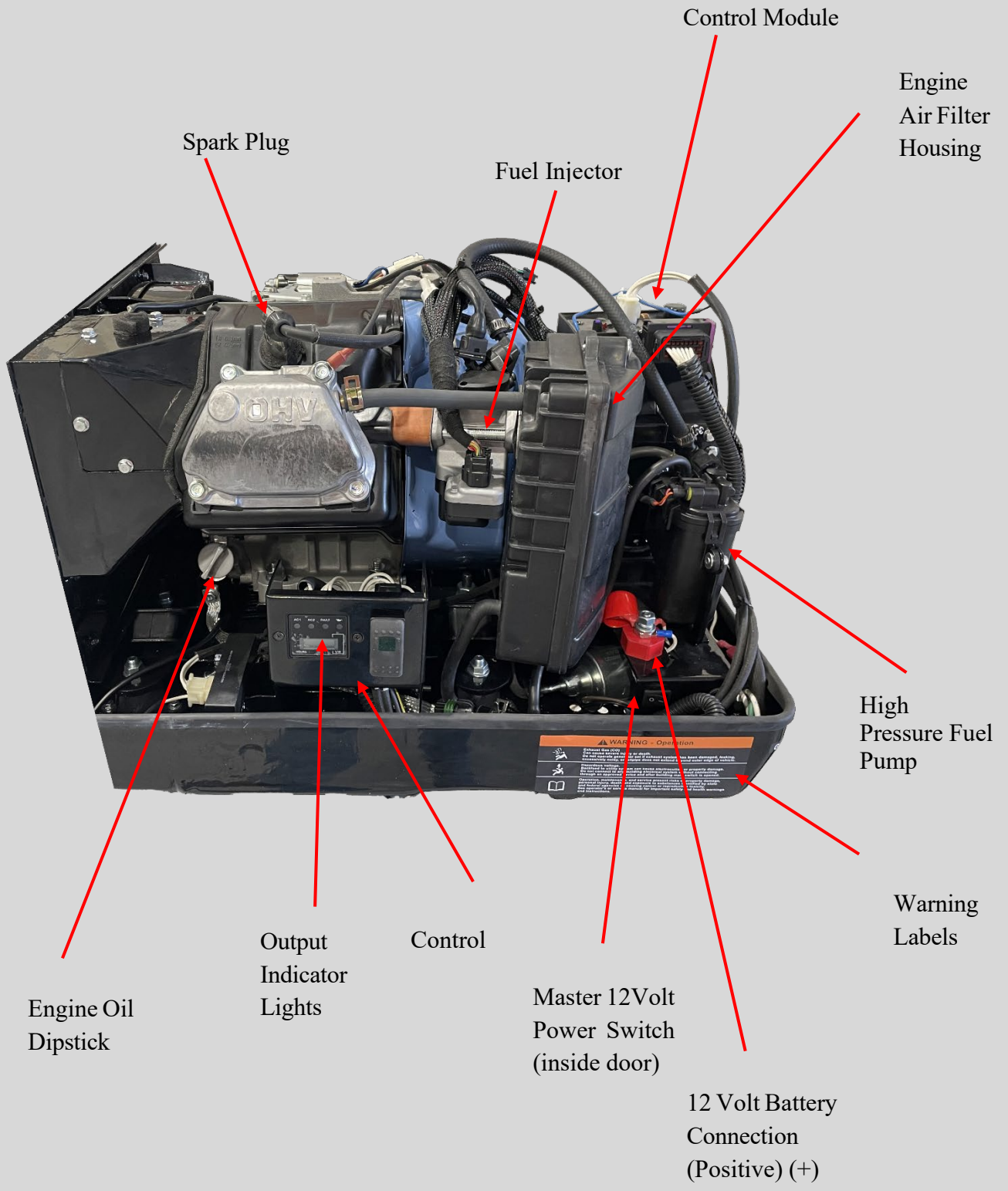

Spark Plug

Fuel Injector

Control Module

Engine  
Air Filter  
Housing

High  
Pressure  
Fuel  
Pump

Warning  
Labels

Master 12Volt  
Power Switch  
(inside door)

12 Volt Battery  
Connection  
(Positive) (+)

Control

Output  
Indicator  
Lights

Engine Oil  
Dipstick

# Exhibit 4 - Generator Base

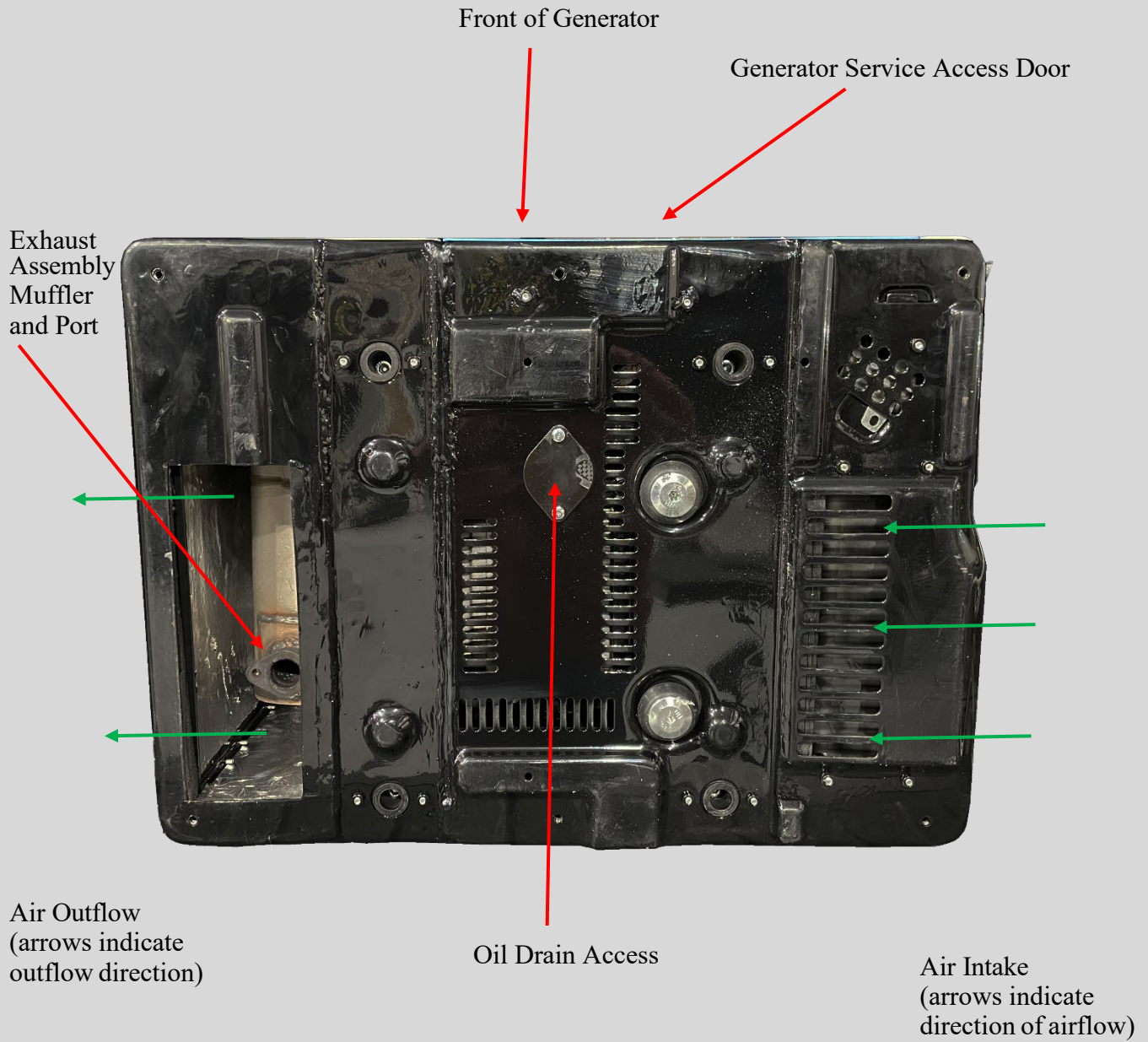

## D. Installation Kit

### Use only authorized, approved and certified parts for installation and maintenance of NPS Generators

**D.1** NPS Generator should be installed using only NPS authorized parts, installation equipment and kits as listed below. Failure to do so may void NPS' Limited Warranty and may result in death or extreme bodily injury to installer or operator

**D.2** Any non-motorized RV, to be powered by an NPS Generator NPS4500efi, NPS6000efi, must be previously prepped with an ECI certified NPS fuel connection system. This requirement does not apply to motorized RVs. All motorized RV chassis fuel systems are approved for use with NPS Generator Models NPS4500efi, NPS6000efi. See [Exhibit 1](#).

**D.3** Model NPS4500efi, NPS6000efi

- Generator Unit. See [Exhibit 2](#).
- Exhaust Kit. See [Exhibit 6](#).
  - Exhaust Flange to Generator Unit and attached bolts (2)
  - Exhaust Pipe
  - Downpipe (4", 7" or 13") to be selected by installer based on individual Model application
  - Downpipe Flange and attached bolts (2)
  - Support Strap with Clamp and attached bolts (2)
- NPS Electrical Components. See [Exhibits 10, 11, 12, 13, 14](#).
  - Hand-held Remote Start KeyFob
  - Remote Start Panel
  - Wiring Harness for Remote Panel
  - Liquid-tight Conduit, Connector and Output Leads (pre-attached to Generator)
- Generator Installation Kit. See [Exhibit 5 and Exhibit 16](#).
  - Bracket Floor Cutout Template
  - Self Tapping Screw (1)
  - Grade 8 Installation Bolts (6)
  - Engine Manual

## D. Installation Kit

### **WARNING**

**D.4** Prior to beginning the installation, inspect all Generator component parts **noting any out-of-place or damaged parts or connections.** Should this preliminary inspection reveal any factory installed Generator components to be out of compliance with this Guide contact the dealer or NPS at for guidance, prior to commencing with the Generator installation.

# Exhibit 5 - Generator Installation Kit



Start/Stop Switch  
w/wires

Grade 8 Installation



Generator Installation Bracket  
floor Cut-out Template

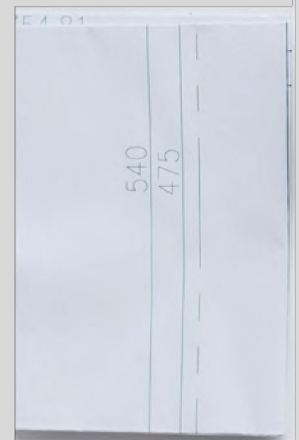

## E. Generator Install Location



### E.1 DANGER! CO POISONING and ENGINE EXHAUST INHALATION

Gasoline-powered engines and tools present a serious health hazard. They produce high concentrations of CO and other toxic substances in their associated fumes and vapors which, when inhaled in high concentrations, may result in death or extreme bodily injury to the installer. CO is a poisonous, toxic, odorless, colorless and non-irritating gas, which is given off whenever fuel or other carbon-based materials are burned. CO can rapidly accumulate (even in areas appearing to be well ventilated), and can overcome exposed persons without warning. Unsafe levels of CO may exist near running gas generators or near air outflow, venting or exhaust from Generator. CO is a poisonous gas that can cause illness, permanent neurological damage and death. Breathing CO may produce headache, dizziness, vomiting and nausea and, in high concentrations, unconsciousness or death. Exposure to CO at moderate to high levels, over long periods of time, as also been linked with increased risk of heart disease.

**Prior to proceeding with Generator installation:**

- **Ensure installation area is equipped with a working CO/smoke detector**
  - **Verify detector is functioning properly prior to commencing with Generator installation**
- **Ensure RV is equipped with working CO/smoke detector**
  - **Verify detector is functioning properly prior to spending time in RV while Generator is operating**
- **DO NOT smoke or permit others to smoke at any time in or around the installation work site**

### **WARNING**

**E.2 Generator must be mounted and installed in a location where exhaust vapors are kept from entering the interior area of the RV both from interior and exterior source points**

**E.3** Install location for Generator should be based on RV model specific requirements and designs

**E.4** Generator install location must allow for Exhaust Kit to be installed where, during travel and operation, significant moisture, dirt or road debris are kept from entering exhaust pipe or Generator air intake. See [Exhibits 6, 7, 8 and 9](#)

**E.5** Install location will determine length of down pipe to be used from NPS provided with Exhaust Kit. See [Exhibit 6, 7, 8 and 9](#)

**E.6** Generator shall be installed to ensure air intakes are protected and shielded from foreign contaminants and road debris during transportation and operation.

**E.7** Forward facing exhaust is permitted on fifth-wheel applications.

## E. Generator Install Location

### **WARNING**

**E.8** Use provided Generator Installation Bracket Floor Cut-out Template to verify the metal mounting bracket was made correctly and holes and air intake and air outflow areas are cut correctly. See [Exhibits 5 and 16](#)

**E.9** Install Generator in a way which does not inhibit the removal of the Generator Service Access Door for proper and routine operation and maintenance. See [Exhibits 2 and 3](#)

### **WARNING**

**E.10** Generator and exhaust operate at a high temperature, therefore installation of Generator shall not be in the same compartment or housing with any flammable vapor, combustible material or ignition sources.

## F. Preparation, Clearances, Ventilation and Air Ducting

### CAUTION

**Any obstruction of Generator air intake or air outflow opening increases risk of overheating and possible equipment damage or failure**

**F.1** Model NPS4500efi, NPS6000efi Generators have a specially designed cooling system. For this cooling system to operate correctly, Generator must be installed where air intake and air outflow openings on Generator pan are unobstructed and line-up exactly with corresponding openings in the installation bracket plate to ensure proper cooling is achieved. See [Exhibits 5 and 16](#).

**F.2** Due to the proximity between the air intake, air outflow and exhaust pipe, the exhaust pipe must be installed exactly as set forth in this Guide to allow for proper cooling.

**F.3** When installing Generator, it is critical that rough-edged openings in the bottom of the Generator housing or any other metal or RV component, do not in any way, block or prevent proper air circulation to or from the Generator. The Generator is designed to duct outflow air away from the cooler intake air entering Generator base. Direction of outflow and intake air must not be altered or redirected by any RV component.

**F.4** Use provided Generator Installation Bracket Floor Cut-out Template to verify the Installation Bracket was made correctly. Verify holes, air intake and air outflow areas are cut correctly. See [Exhibits 5 and 16](#)

**F.5** Minimum clearance requirements for Generator installation are (for ease of reference, front of generator shall be where the Generator service access door is located)

- not less than 25.4 mm (1") on the left side
- not less than 25.4 mm (1") at the top
- not less than 38.1 mm (1.5") from front of Generator to RV access door
- not less than 6.35 mm (0.25") on right side and back side
- not less than 406.4 mm (16") from Generator pan to the ground

### WARNING

**F.6 Minimum clearances apply to all components within the Generator housing compartment.**

**F.7** At all times during Generator operation, an area of not less than 406.4 mm (16") between Generator and the ground and extending 914 mm (3') from the Generator in all directions, must be free and clear of any debris, obstructions, or non-factory installed equipment. NPS reserves the right to allow modifications of these heights only with written approval.

## G. Generator Housing, Installation and Mounting



### G.1 DANGER! CO POISONING and ENGINE EXHAUST INHALATION

Gasoline-powered engines and tools present a serious health hazard. They produce high concentrations of CO and other toxic substances in their associated fumes and vapors which, when inhaled in high concentrations, may result in death or extreme bodily injury to the installer. CO is a poisonous, toxic, odorless, colorless, and non-irritating gas, which is given off whenever fuel or other carbon-based materials are burned.

CO can rapidly accumulate (even in areas appearing to be well ventilated) and can overcome exposed persons without warning. Unsafe levels of CO may exist near running gas generators or near air outflow, venting or exhaust from Generator. CO is a poisonous gas that can cause illness, permanent neurological damage, and death. Breathing CO may produce headache, dizziness, vomiting and nausea and, in high concentrations, unconsciousness or death. Exposure to CO at moderate to high levels, over long periods of time, has also been linked with increased risk of heart disease.

#### Prior to proceeding with Generator installation:

- Ensure installation area is equipped with a working CO/smoke detector.
  - Verify detector is functioning properly prior to commencing with Generator installation
- Ensure RV is equipped with working CO/smoke detector
  - Verify detector is functioning properly prior to spending time in RV while Generator is operating



### G.2 DANGER! GASOLINE and VAPORS are FLAMMABLE and EXPLOSIVE

#### Throughout the installation process:

- Keep multi-class ABC fire extinguishers within reach of installer and readily available
- All rags soiled with gasoline or oil must be discarded in a fire-proof container
- Routinely check for leaks and collections of gasoline pooling in install area
- Secure and shield fuel lines separately and away from electrical wiring to prevent accidental ignition
- Keep all ignition sources away from fuel lines and including:
  - open flames
  - arc producing equipment
  - sparks
  - pilot lights
  - electrical switches
- **DO NOT** smoke or permit others to smoke at or near install location

## G. Generator Housing, Installation and Mounting



**G.3** Generator and exhaust assembly must be mounted and installed in the designated locations where exhaust vapors are kept from entering the living area of RV both from Generator housing, windows, or other exterior source points. Failure to adhere to warnings, clearance requirements and properly seal housing may result in extreme bodily injury or death to installer or operator

**G.4** Generator Housing must be constructed in accordance with all RVIA/ANSI, NFPA and NEC construction standards and is required to meet all applicable state and federal construction and safety requirements as well as your Manufacturers internal construction and generator housing standards. Care should be taken to inspect housing before and after installation to ensure complete integrity of housing and corresponding seals. Any damage to housing may allow harmful vapors to penetrate housing and enter inside the living area of the RV.

**G.5** Use the Generator Installation Bracket Floor Cut-out Template (See [Exhibits 5 and 16](#)) to verify the Bracket was made correctly and all holes and air intake and air outflow areas are cut correctly

**G.6** Install NPS supplied six (6) Grade 8 steel bolts (See [Exhibit 5](#)) through the Generator Installation Bracket then through pre-attached rubber isolation feet. See [Exhibit 4](#).

**G.7** Use a torque wrench or torque stick for installation of NPS supplied installation Grade 8 steel bolts (6) 5/16-18 NC. Lengths for Grade 8 steel bolts are:

- For towable segment RVs, 31.75mm (1.25")
  - Torque should be 27.116 Nm (20 ft-lbs)
- For motorized segment RVs, 57.15mm (2.5")
  - Torque should be 27.116 Nm (20 ft-lbs)

### **WARNING**

**G.8** The electrical, fuel, and exhaust connections to the Generator may be made at any time, in any order, but all must be completed PRIOR to connecting the negative (-) DC power on the battery.

# H. Exhaust Kit Installation

## H.1 Spark Arrester

The Generator exhaust is equipped with a U.S. Forest Service approved spark-arrest muffler. NPS generators are designed with a spark-arrest feature to meet U.S. Forest Service requirements. Spark arrestors should not be removed. Removal of, or failure to install the spark arrester, may be a violation of state law.

Tampering with or making any unapproved modification of the exhaust system voids NPS' Limited Warranty and places liability on the party making the modification. NPS does not accept liability for any damage or injury resulting from an unapproved modification. See [Exhibits 6, 7, 8 and 9](#).



## H.2 DANGER! CO POISONING and ENGINE EXHAUST INHALATION

Gasoline-powered engines and tools present a serious health hazard. They produce high concentrations of CO and other toxic substances in their associated fumes and vapors which, when inhaled in high concentrations, may result in death or extreme bodily injury to the installer. CO is a poisonous, toxic, odorless, colorless, and non-irritating gas, which is given off whenever fuel or other carbon-based materials are burned.

CO can rapidly accumulate (even in areas appearing to be well ventilated) and can overcome exposed persons without warning. Unsafe levels of CO may exist near running gas generators or near air outflow, venting or exhaust from Generator. CO is a poisonous gas that can cause illness, permanent neurological damage and death. Breathing CO may produce headache, dizziness, vomiting and nausea and, in high concentrations, unconsciousness or death. Exposure to CO at moderate to high levels, over long periods of time, has also been linked with increased risk of heart disease.

### **Prior to proceeding with Generator installation:**

- Ensure installation area is equipped with a working CO/smoke detector.
  - Verify detector is functioning properly prior to commencing with Generator installation.
- Ensure RV is equipped with working CO/smoke detector.
  - Verify detector is functioning properly prior to spending time in RV while Generator is operating.

# H. Exhaust Kit Installation

---



**MANDATORY  
ACTION**

## H.3 DANGER! GASOLINE and VAPORS are FLAMMABLE and EXPLOSIVE

### Throughout the installation process:

- Keep multi-class ABC fire extinguishers within reach of installer and readily available
- All rags soiled with gasoline or oil must be discarded in a fire-proof container
- Routinely check for leaks and collections of gasoline pooling in install area
- Secure and shield fuel lines separately and away from electrical wiring to prevent accidental ignition
- Keep all ignition sources away from fuel lines and including:
  - open flames
  - arc producing equipment
  - sparks
  - pilot lights
  - electrical switches
- **DO NOT** smoke or permit others to smoke at or near install location

**PROHIBITION**

H.4 Use only the approved NPS NPS4500efi, NPS6000efi exhaust kit for all NPS Generator Model installations.

**WARNING**

H.5 The generator exhaust system is engineered to prevent exhaust gases from entering the living area of the RV. It is critical that the clamps are secured tightly to prevent gas vapors and CO from escaping prior to the outlet of the exhaust. See [Exhibits 6, 7, 8 and 9](#).

**ATTENTION**

H.6 Determine what length of downpipe (included in the installation kit) is necessary to extend the exhaust pipe to meet exhaust clearance requirements. Downpipe is shown in [Exhibit 6](#).

H.7 The use of the downpipe will depend on Generator install location for specific RV model applications.

## H. Exhaust Kit Installation

**H.8** Generator Exhaust pipe should be installed with no less than 76.2 mm (3") clearance beyond metal skirting or trim. (1 1/2") in motorized applications with no flammables present.

- **DO NOT** terminate the tailpipe underneath the vehicle. See [Exhibits 7, 8 and 9](#).

**H.9** The exhaust pipe is installed by sliding the collar end (female) over the male pipe. See [Exhibit 4](#).

- Secure exhaust flange around collar where collar joins with base of generator.
- Tighten Bolts on Exhaust Flange. See [Exhibit 6](#).

**H.10** If downpipe is used, secure downpipe collar over male pipe extending from Generator and secure with downpipe flange. See [Exhibit 6, 7, 8 and 9](#)

- Tighten downpipe flange bolts.
- Next, the collared end of Exhaust Pipe slides up over end of downpipe and is secured with Exhaust Pipe flange.
- Tighten Exhaust Pipe flange bolts.

**H.11** Installation kit includes an Exhaust Support Strap and Clamp. See [Exhibit 6 and 7](#).

- Attach Exhaust Support Strap to a sufficiently strong metal or non-combustible structural component of the RV, using the Self-tapping screw provided in the Installation kit. See [Exhibit 6](#).

**H.12** Ensure Exhaust assembly (exhaust pipes, downpipes) is a minimum of 152.4mm (6") from any combustible materials and a minimum of 914.4 mm (3') from non-sealed access or openings into the living area or unsealed storage area of RV including doors, windows, etc. NPS reserves the right to allow modifications of these heights only with written approval.

## H. Exhaust Kit Installation

### Fifth-wheel Exhaust Assembly Install Configuration:

**H.13** Connect horizontal portion of Exhaust pipe to Exhaust Support Strap utilizing the Exhaust Support Strap Clamp. See [Exhibits 6, 7, 8 and 9](#).

- Tighten bolts on Support Strap Clamp.
- Exhaust assembly (exhaust pipes, downpipes, and flanges) must be connected to horizontal portion of Exhaust Pipe to prevent Exhaust Pipe from being moved or pushed back under edge of trailer skirting. See [Exhibits 6, 7, 8 and 9](#).

### **WARNING**

**H.14** Exhaust Assembly must be installed with a minimum clearance of 304.8 mm (6") from any fuel system component.

**H.15** Use Self-tapping screw to secure the exhaust support strap to a strong and suitable, permanent member of RV frame. See [Exhibit 6](#).

### Bumper-Pull Exhaust Assembly Install Configuration:

**H.16** Depending on the bumper-pull model, the trailer skirt may need to be trimmed out around the Exhaust Pipe to ensure proper minimum clearance distances.

- If skirting is trimmed, flexible rubber molding should be installed on the rough edge of the trimmed metal to prevent the Exhaust Support Strap from being damaged by vibration against the trailer skirting. See [Exhibit 9](#).
- When possible, downpipe should be used or omitted as necessary to maintain a clearance minimum of 76.2 mm or (3") from bottom of bumper-pull skirting to top of Exhaust Pipe. See [Exhibit 9](#).

**H.17** Use Self-tapping screw to secure the exhaust support strap to a strong and suitable, permanent member of RV frame. See [Exhibits 6 and 9](#).

# Exhibit 6 - NPS4500efi, NPS6000efi Exhaust Kit

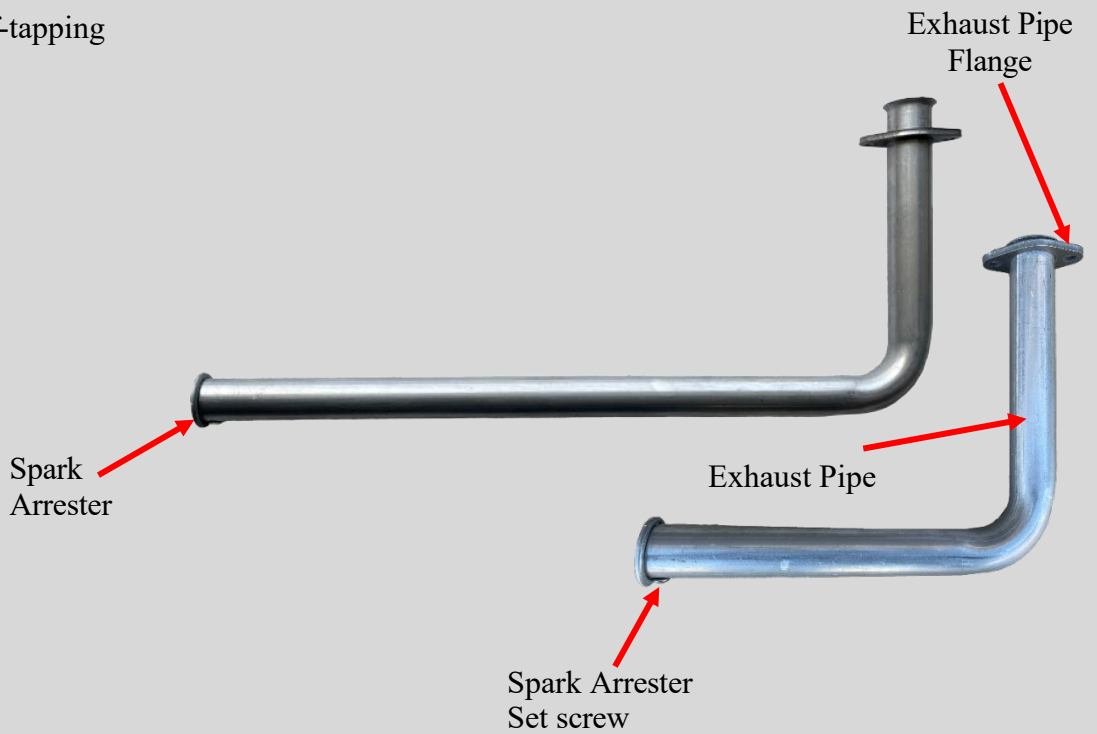
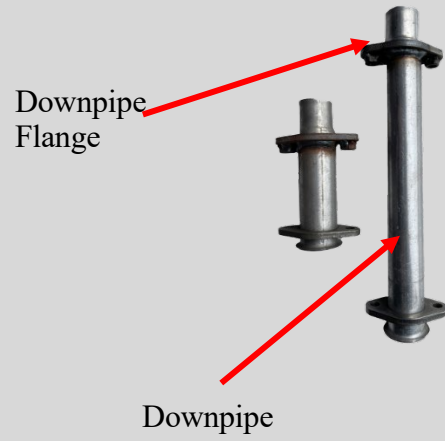
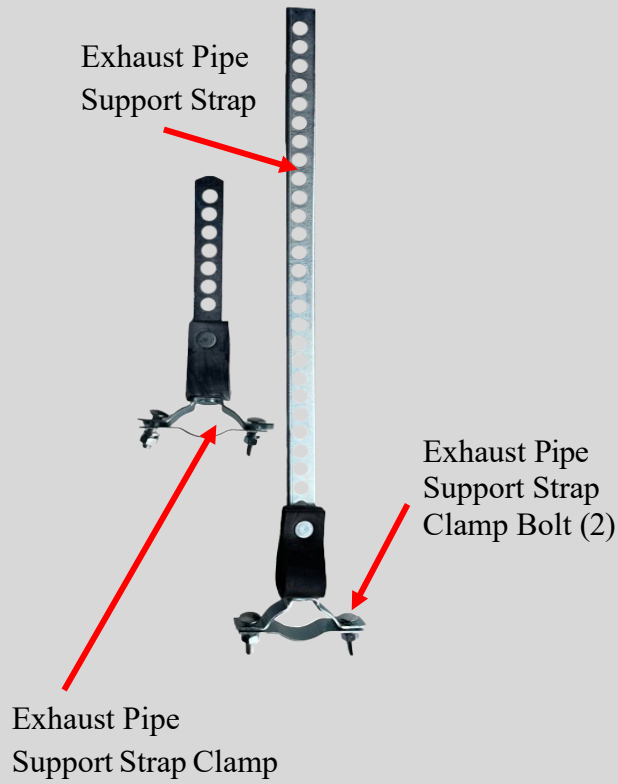

# Exhibit 7 - Fifth-Wheel Generator Exhaust Assembly

End of Exhaust Pipe must extend no less than 25.4 mm (1") beyond outer metal skirting or trim



Clearance minimum of 76.2 mm or (3") and maximum of 101.6 mm or (4") from bottom of fifth-wheel skirting to top of Exhaust Pipe

## Exhibit 8 - Fifth-wheel Generator Exhaust Placement

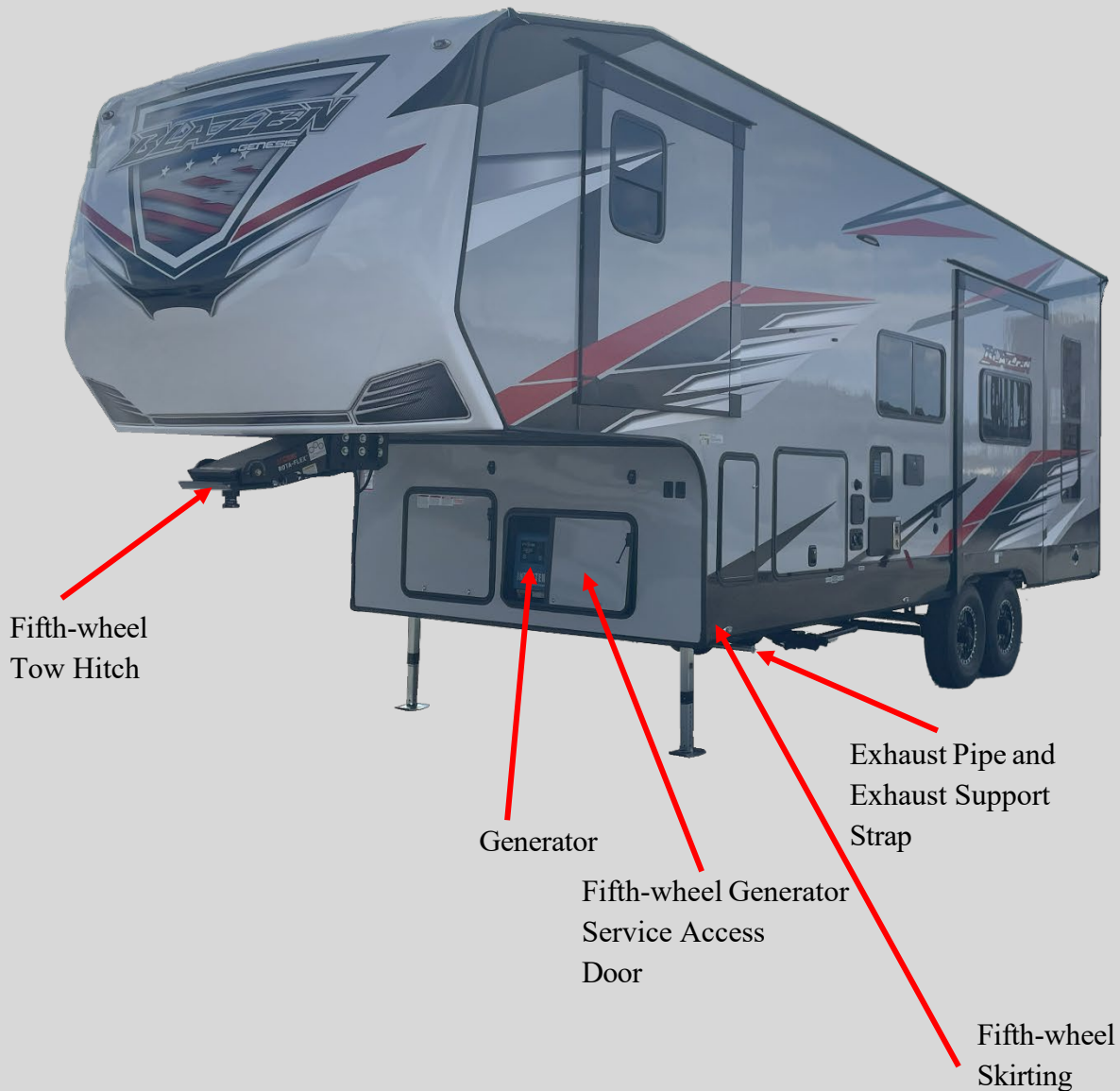

Exhaust should be installed so the horizontal portion of the Exhaust Pipe is level. When possible, downpipe should be omitted to maintain a clearance minimum of 76.2 mm or (3") and maximum of 101.6 mm or (4") from bottom of fifth-wheel skirting to top of Exhaust Pipe. See [Exhibit 7](#).

## Exhibit 9 - Bumper-Pull Exhaust Assembly Configuration

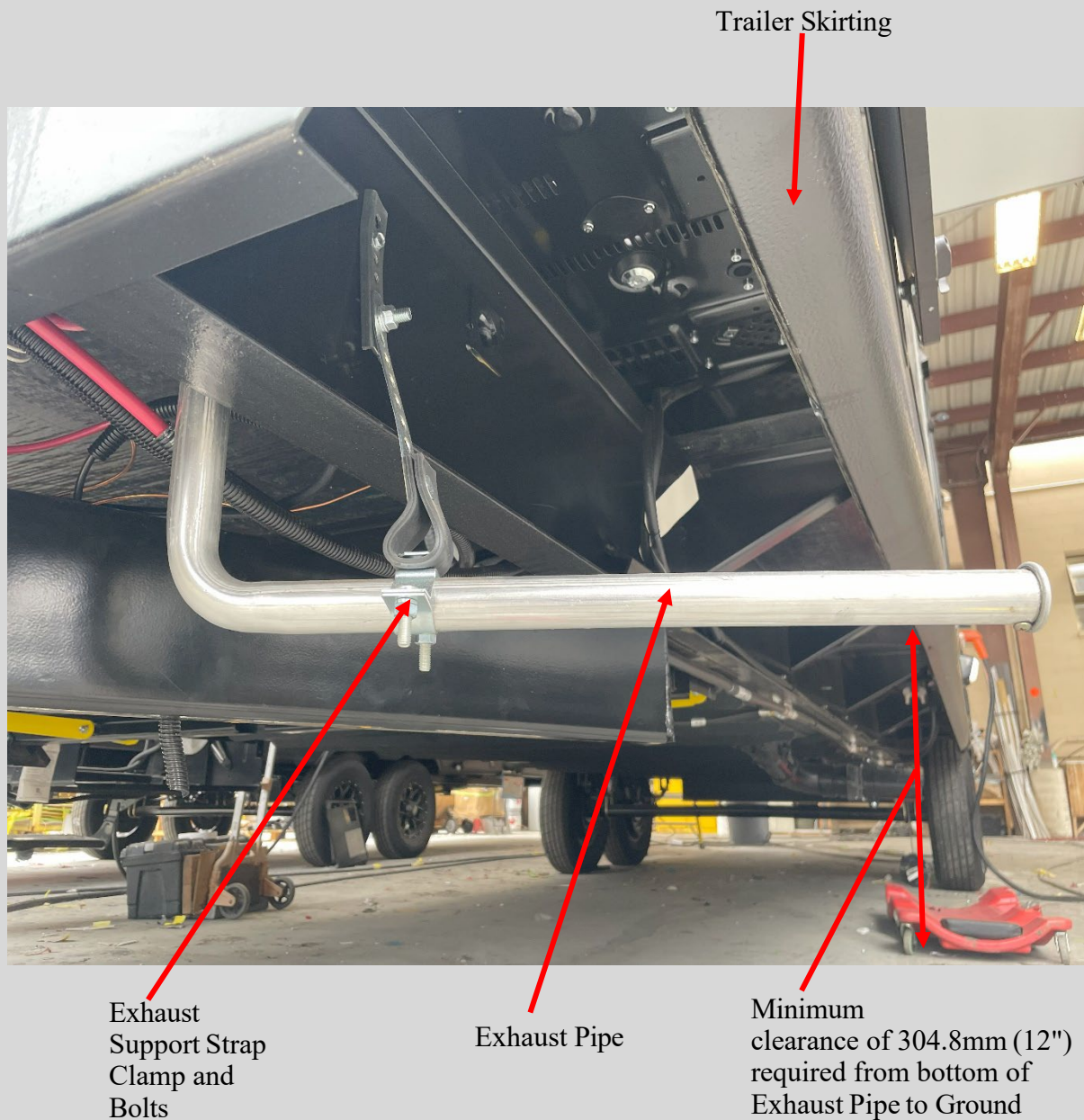

Depending on the bumper-pull model, the trailer skirt may or may not need to be trimmed out around the Exhaust Pipe to ensure proper minimum clearance distances. If skirting is trimmed, heat resistant flexible rubber molding should be installed on the rough edge of the trimmed metal to prevent the Exhaust Support Strap from being damaged by vibration against the trailer skirting. When possible, downpipe should be used or omitted as necessary to maintain a clearance minimum of 76.2 mm or (3") from bottom of bumper-pull skirting to top of Exhaust Pipe.

# I. Electrical Connection



**DANGER!** Prior to proceeding with any electrical connections, installers must read and understand the entire "I. Electrical Connection" section of this Guide. Wiring incorrectly run, connected, or damaged may create an electrical arc, shock or fire and could result in death or extreme bodily injury to the installer or operator.

## **WARNING**

**I.1** The electrical, fuel and exhaust connections to the Generator may be made at any time, in any order, but all must be completed **PRIOR** to connecting the negative (-) DC power on the battery.

**I.2** Prior to installing or making any wiring connections verify DC negative (-) battery cable is disconnected



**I.3 DANGER! Generator Voltage: ELECTRICAL ARC, SHOCK and FIRE HAZARD**

**Prior to performing any work on the Generator:**

- Identify and designate all electrical connections as either energized or non-energized to all service team members.
- Verification of energized or non-energized connection(s) or surfaces must be constantly monitored by a qualified technician throughout the Generator installation
- Test equipment shall be used to ensure that electrical parts and circuit elements have been de-energized prior to performance of any and all Generator installation segments
- Testing instruments and equipment shall be visually inspected for external defects or damage before being used to determine de-energization (29 CFR 1910.334(c)(2))



**I.4 DANGER! Generator Voltage: ELECTRICAL ARC, SHOCK and FIRE HAZARD**

**Prior to working on live or potentially live electrical equipment:**

- Disconnect shore power to RV
- Disconnect negative (-) terminal at battery(ies)
- Remove any metal or conductive apparel. Articles of jewelry and clothing such as metal: watch bands, bracelets, rings, keychains, necklaces, ear or other metal piercings, metalized aprons, cloth with conductive thread, or metal headgear shall not be worn. (29 CFR 1910.333(c)(8))
- NPS recommends working on dry non-conductive material
- Ensure clothes, hands and hair are dry
- Condition specific PPE, including safety glasses, must be worn to protect eyes and face from electric arcs, flashes or from flying objects resulting from an electrical explosion
- Use only tools with non-conductive and/or non-combustible covered handles

# I. Electrical Connection

---



**MANDATORY  
ACTION**

## **I.5 DANGER! Generator Voltage: ELECTRICAL ARC, SHOCK and FIRE HAZARD (continued)**

- Electrical connections shall be made by a qualified person experienced and familiar with the construction and operation of electrical equipment and the hazards involved. Qualified persons are intended to be only those well acquainted with and thoroughly conversant in electric equipment and electrical hazards involved with work being performed
- Review placard and warnings on Generator for amperage and voltage information to protect installers and operators from hazards which could cause injury due to electric shock, burns or failure of electrical components
- Visually inspect all Generator mounting components (Exhaust Assembly, Service Access Door, Fuel Connections, Electrical Connections, Remote Control Panel) and every ten (10) hours of operation thereafter
- **NPS' Generators are not designed to be a primary source of power for life support systems or devices but can support temporary operating or charging of recreational or battery powered components**

**WARNING**

**ALERT**

### **AC Power Connection (120 Volt) - Generator to RV Transfer Switch**

**WARNING**

**PROHIBITION**

**I.6 DO NOT** run the Remote Start Panel wires and the 120Volt leads next to each other. Proximity of the two wire sets may result in electrical signal interference to the hard line Remote Start Panel inside the RV.

**WARNING**

**ALERT**

**I.7 When running wiring, be alert to any sharp edges or metal RV components, which could damage or compromise wiring or its insulation, either upon initial contact or because of vibration from normal operations. Damage to any part of the wiring may create an electrical arc flash, fire or electrical shock and could result in death or extreme bodily injury to the installer or operator.**

**WARNING**

**ALERT**

**I.8 When running wiring, be alert for any RV components or parts, which may be hot and compromise the integrity of the wiring or its insulation. Damage to any part of the wiring may create an electrical arc flash, fire or electrical shock and could result in death or extreme bodily injury to the installer or operator.**

**WARNING**

**MANDATORY  
ACTION**

**I.9 Prior to routing or connecting or feeding the output leads into the transfer switch:**

- **Verify NO POWER is being supplied to the transfer switch in compliance with the transfer switch manufacturer guidelines.**
- **An energized transfer switch may create an electrical arc flash, fire or electrical shock and could result in death or extreme bodily injury to the installer or operator.**

# I. Electrical Connection

## AC Power Connection (120 Volt) - Generator to RV Transfer Switch (continued)

**I.10** Locate the liquid-tight conduit attached to the Generator, containing the 120 Volt leads. See [Exhibit 10](#).

**I.11** Familiarize yourself with the RV transfer switch manufacture guidelines, prior to attempting an electrical connection from the Generator to the transfer switch.

- Consult the RV manufacturer guidelines for model specific wiring route(s)
- **Determine location of exhaust system, if it was installed prior to routing the wiring and electrical connections**
- Verify the recommended wiring route from the Generator to the RV transfer switch complies with all **WARNINGS** in this Guide
- **All connections need to be made by fully hand-starting the threaded nut onto threads before applying torque, to avoid cross threading**

**II.12** Remove the threaded nut from the end of the liquid-tight conduit connector. See [Exhibit 10](#) (set aside for connecting the liquid-tight conduit to the transfer switch housing).

**I.13** Hand-thread the opposite side of the liquid-tight conduit connector over the output leads and onto the liquid-tight conduit.

**I.14** Slide output leads into the round hole in the transfer switch housing (refer to RV transfer switch manufacturer guidelines for exact placement)

**I.15** From inside of the transfer switch housing, slide, the previously removed, liquid-tight conduit connector threaded nut over the output leads and reconnect it to the liquid-tight conduit connector.

**I.16** Verify you have adequate wire length for connection prior to tightening.

- Secure nut inside transfer switch housing and tighten opposite side of liquid-tight conduit connector onto the liquid-tight conduit, securing the liquid-tight conduit and output leads to the transfer switch housing
- Proceed with connecting output leads as set forth by the transfer switch manufacturers guidelines

# I. Electrical Connection

---

## DC Power Connection (12Volt) - Generator to RV Battery Compartment



**MANDATORY  
ACTION**

### I.17 DANGER! ELECTRICAL ARC, SHOCK and FIRE HAZARD

Prior to performing any work on the DC Power Connection, verify the black negative (-) cable is disconnected and the battery is de-energized. Failure to disconnect negative (-) cable may create an electrical arc flash, spark or fire and could result in death or extreme bodily injury to the installer or operator.



**MANDATORY  
ACTION**

I.18 DC Power Connections must always follow a strict protocol of disconnecting the black negative (-) battery cable first and then disconnecting the red positive (+) battery cable. When reconnecting the DC Power Connection, the red positive (+) battery cable must be connected first, and the black negative (-) battery cable must always be connected last. Failure to follow this strict sequence will result in an electrical arc flash and may result in death or extreme bodily injury to the installer or operator.

### I.19 Locate the battery compartment in the RV.

- Locate the red positive (+) battery terminal.
- Route or connect the red positive (+) battery cable to the red positive (+) terminal on the Generator.
- Locate the black negative (-) battery terminal.
- Route or connect the black negative (-) battery cable to the black negative (-) terminal on the Generator. If connecting complete only after entire installation is completed.

**ATTENTION**

II.20 Before starting Generator verify the RV battery(ies) are fully charged.

# I. Electrical Connection

---

## I.21 DANGER! ELECTRICAL ARC FLASH, SPARK and FIRE HAZARD



MANDATORY  
ACTION

Prior to performing any work on the DC Power Connection, verify the black negative (-) cable is disconnected and the battery is de-energized. Failure to disconnect negative (-) cable may create an electrical arc flash, spark or fire and could result in death or extreme bodily injury to the installer or operator.

I.22 DANGER! DC Power Connections must always follow a strict protocol of disconnecting the black negative (-) battery cable first and then disconnecting the red positive (+) battery cable. When reconnecting the DC Power Connection, the red positive (+) battery cable must be connected first, and the black negative (-) battery cable must always be connected last. Failure to follow this strict sequence will result in an electrical arc flash and may result in death or extreme bodily injury to the installer or operator.



MANDATORY  
ACTION

I.23 When running wiring, be alert to any sharp edges or metal RV components, which could damage or compromise wiring or its insulation, either upon initial contact or as a result of vibration from normal operations. Damage to any part of the wiring may create an electrical arc flash, fire or electrical shock and could result in death or extreme bodily injury to the installer or operator.

WARNING

ALERT

I.24 When running wiring, be alert for any RV components or parts, which may be hot and compromise the integrity of the wiring or its insulation. Damage to any part of the wiring may create an electrical arc flash, fire or electrical shock and could result in death or extreme bodily injury to the installer or operator.

WARNING

ALERT

I.25 DO NOT run the Remote Start Panel wires and the 120Volt leads next to each other. Proximity of the two wire sets may result in electrical signal interference to the hard line Remote Start Panel inside the RV.

WARNING

PROHIBITION

I.26 Locate the Remote Start Wiring Harness and the Remote Start Panel. See [Exhibits 12, 13, 14](#).

I.27 Route the Remote Start Wiring Harness through the RV, between Generator housing compartment and the install location for the Remote Start Panel, based on the specifications for that RV model.

- The spade connector end of the Remote Start Wiring Harness terminates at the Remote Start Panel.
- The black female connector end of the Remote Start Wiring Harness terminates at the Generator.
- Some RV models may not use the Remote Start Panel or any/all of the Remote Start Wiring Harness or connections, please refer to your RV model manufacturer specifications for guidance or contact NPS at (866) 407-1727 or [www.npsrvpower.com](http://www.npsrvpower.com).

INFORMATION

# I. Electrical Connection

---

## Remote Start Panel Connection (continued)

### I.28 At the Remote Start Panel:

- Connect the Generator Hours Meter Connector lock-clip (green and white wires pre-installed on the Remote Start Panel) to the Remote Start Wiring Harness corresponding lock-clip (brown and orange wires) See [Exhibits 11 and 12](#).
- Connect the Remote Start Wiring Harness female spade connectors to the Remote Start Panel male spade connectors. See [Exhibit 12](#).
- Pair female and male spade connectors utilizing the Remote Start Panel Wiring Harness Diagram. See [Exhibit 12](#).
- Verify all Remote Start Panel Wiring Harness spade connectors are fully and securely paired.
- Once Remote Start Panel Wiring Harness is connected to the Remote Start Panel and pairing is verified, securely attach the Remote Start Panel to the RV interior location as specified by the manufacturer for that RV model.

### I.29 At the Generator:

- Locate the black female-end connector of the Remote Start Wiring Harness. See [Exhibit 11](#).
- Route the black female-end connector of the Remote Start Wiring Harness through the rubber grommet, on the right side of the Generator (located above the 12Volt ground connection), from outside the Generator to inside. See [Exhibit 10 and 14](#).
- Securely connect the black female-end connector to the black male-end located inside the Service Access Door and connected by a pigtail to the Generator control module. See [Exhibit 11, 13 and 14](#).

# Exhibit 10 - AC Power and Fuel Connectors

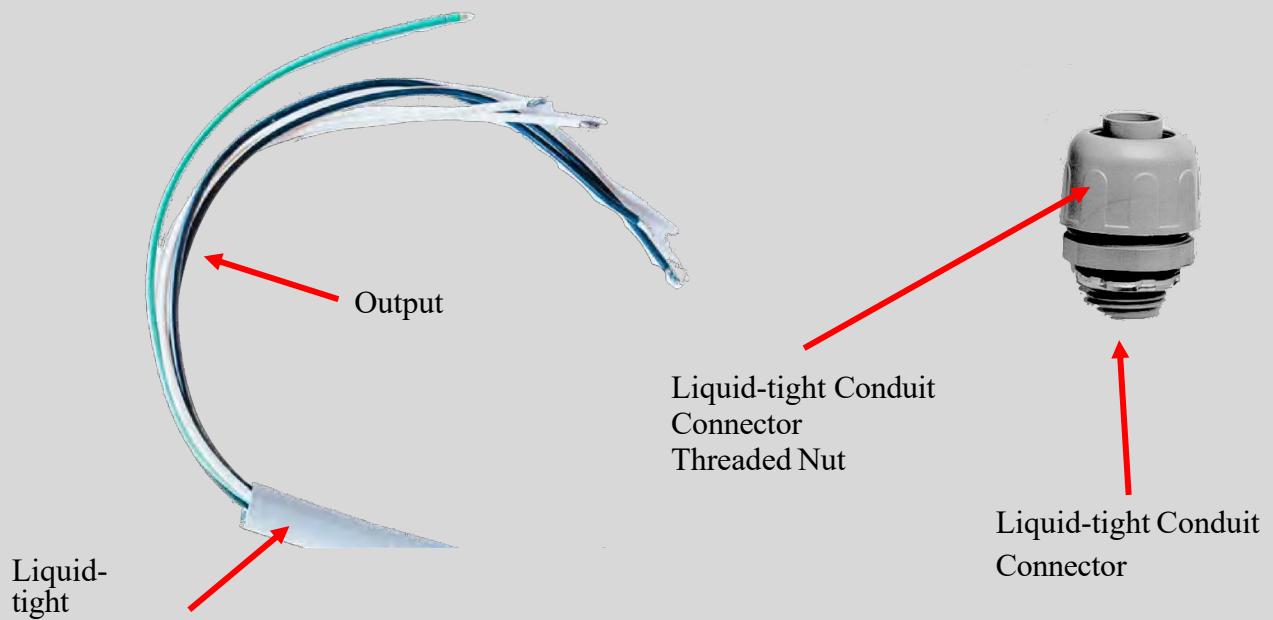
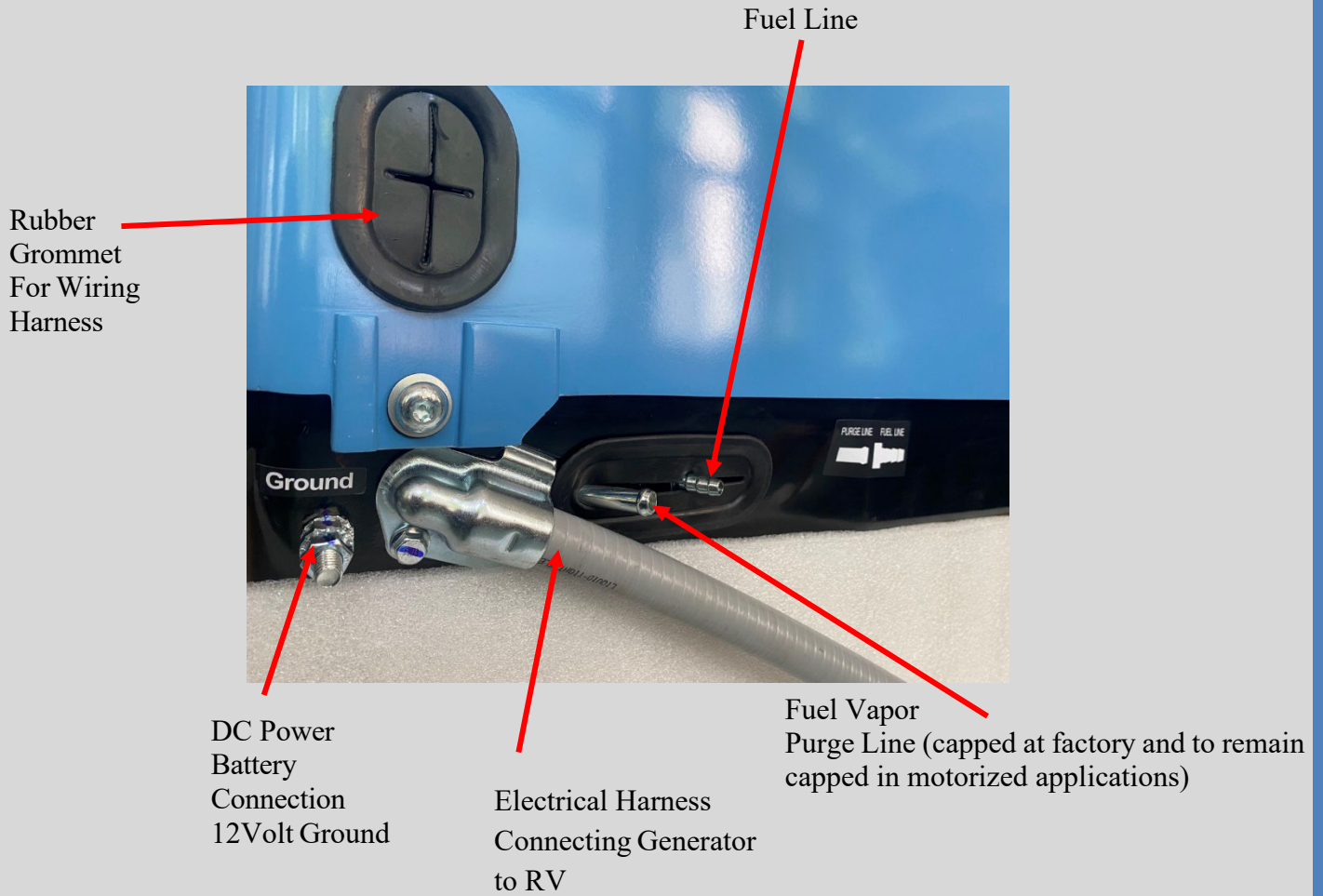

# Exhibit 8 - Electrical Components

Remote Start Panel  
(inside RV front)

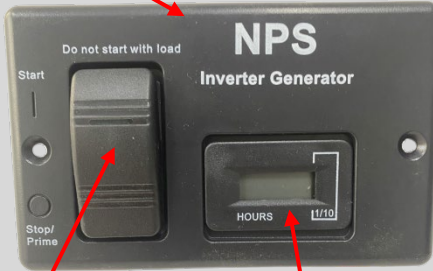

Start/Stop/Prime  
Switch

Generator  
Hours

Remote  
Start  
Panel  
(inside RV)

Hand-held  
Remote  
Start/Stop Keyfob  
(back view with



Start  
Butto

Stop  
Butto

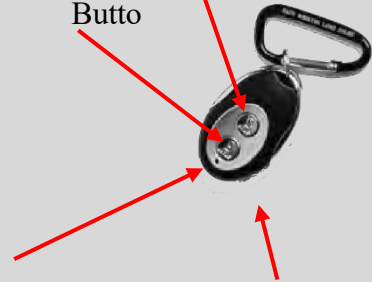

Start Button  
Indicator

Hand-held  
Remote  
Start/Stop Keyfob  
(front view)



Hand-held Remote  
Start/Stop Keyfob  
(inside view with  
battery compartment  
and screws)

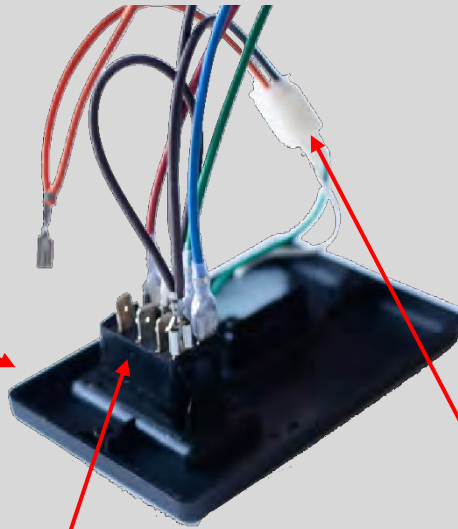

Remote Start  
Panel to Wiring  
Harness male  
spade connectors

Generator Hours  
Meter Connector  
(lock-clip with green and  
white wires) secured to  
back of Remote Start Panel  
(inside RV)

Wiring Harness for  
Remote Start



Wiring Harness to Remote  
Start Panel female spade  
connectors

Black female-end Connector  
of Remote Start Panel  
Wiring Harness for connection to  
black male-end Connector  
located inside Generator  
Service Access Door

Wiring Harness Connector  
to Generator Hours Meter  
(orange and brown wires)  
lock-clips to Generator Hours  
Meter Connector attached to  
Remote Start Panel (white and green

# Exhibit 12 - Wiring Harness - Remote Start Panel Connections

Top of Remote Start Panel (front)

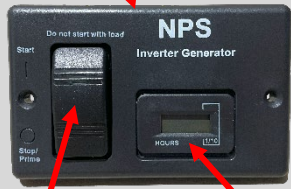

Start Stop/Prime Switch

Generator Hours Meter

Bottom of Remote Start Panel (front)

LCI One Control System (orange jumper)

Bottom of Remote Start Panel (back side)

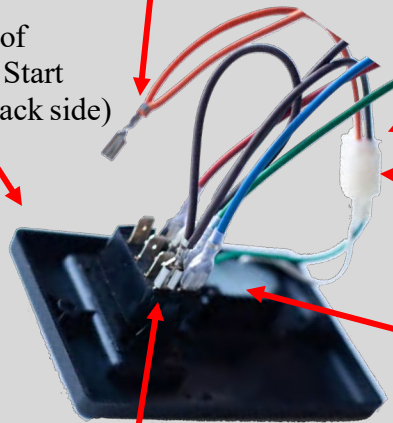

Remote Start Wiring Harness lock-clip (orange and brown wires)

Generator Hours Meter lock-clip (green and white wires, pre-installed on Remote Start Panel)

Generator Hours Meter Display

Start - Stop/Prime Switch spade connectors (diagram)

Top of Remote Start Panel (back side)

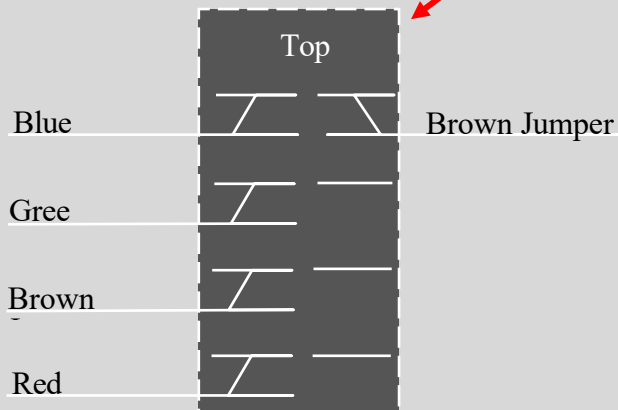

# Exhibit 13 - Wiring Harness Connectors

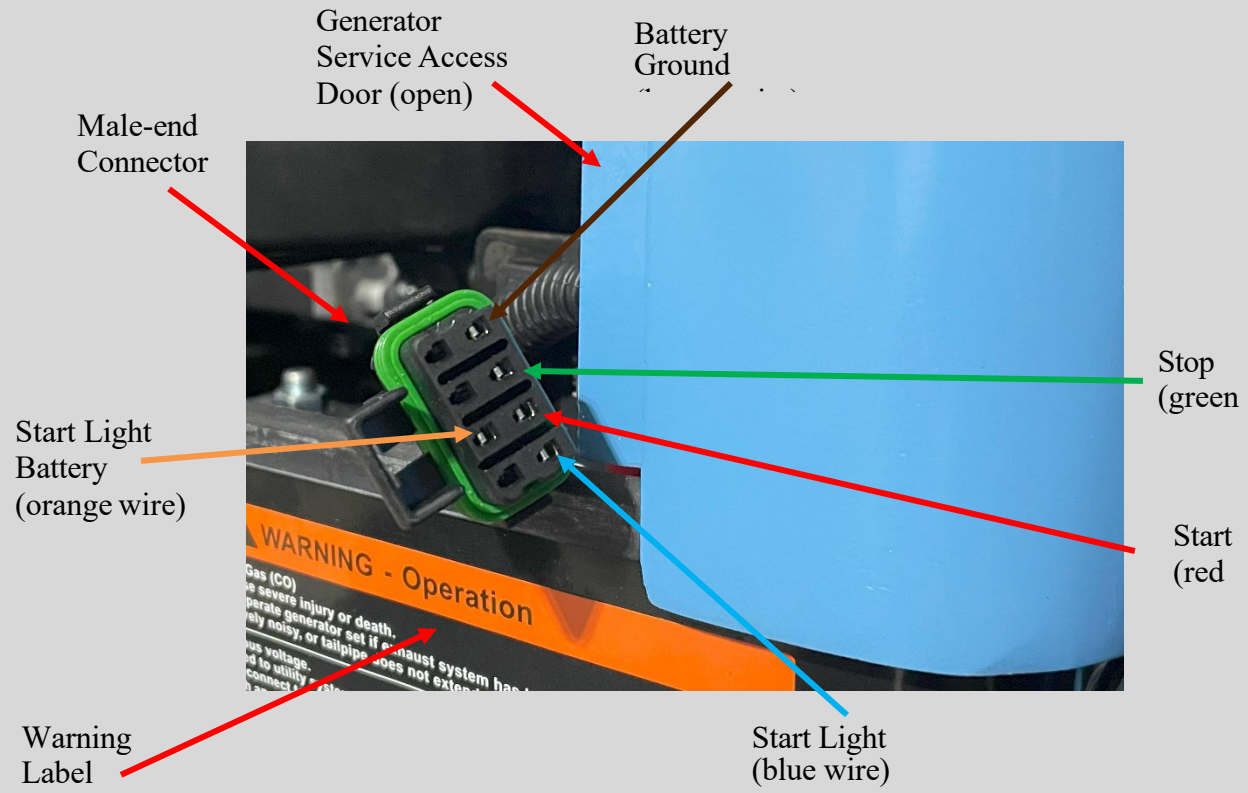
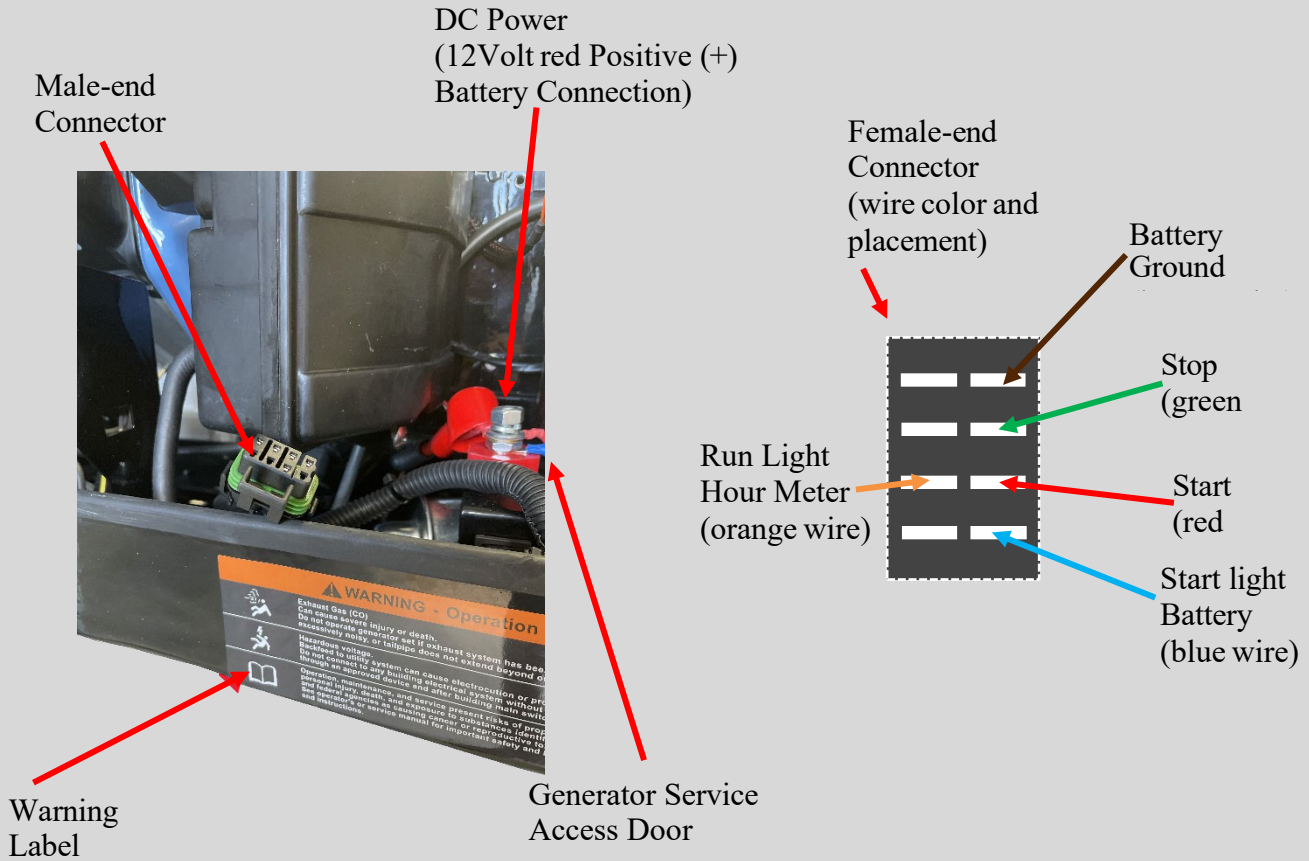

## J. Fuel Connection

---



MANDATORY  
ACTION

### J.1 DANGER! GASOLINE and VAPORS are FLAMMABLE and EXPLOSIVE

- Keep multi-class ABC fire extinguishers within reach of installer and readily available throughout the installation
- **Do not smoke or permit others to smoke at or near install location**
- All rags soiled with gasoline or oil must be discarded in a fire-proof container
- Routinely check for leaks and collections of gasoline pooling in install area
- Secure and shield fuel lines separately and away from electrical wiring to prevent accidental ignition
- Keep all ignition sources away from fuel lines and including:
  - open flames
  - arc producing equipment
  - sparks
  - pilot lights
  - electrical switches

ALERT

J.2 NPS Generators may only be used in towable applications (fifth-wheel and bumper-pull) which are equipped with an ECI fuel system built specifically for connecting to NPS Generators.

WARNING

J.3 RV models equipped with a NPS ECI fuel system will be identified by a red tag. See [Exhibit 1](#).

PROHIBITION

- If this tag is not present or cannot be located on the fifth-wheel or bumper-pull, **DO NOT** proceed with the installation of the Generator.
- **This prohibition does not apply to motorized applications.**

J.4 Locate the fuel line from the RV (refer to your Manufacturer for model specific location)

J.5 Locate the Fuel Line and Purge Line spout off the right side of the Generator (below the rubber grommet for the Remote Start Wiring Harness and along side the 12Volt negative (-) ground connection. See [Exhibit 10](#).

J.6 Slide the end of the RV fuel line over the Generator Fuel Line spout. See [Exhibit 10](#).

J.7 Secure tightly with the RV Manufacturer provided fuel line clamp.

J.8 Check connection for any leaks of fuel or vapors.

## J. Fuel Connection

---

**J.9** Locate the Purge Line from the RV (refer to your Manufacturer for model specific location).

**J.10** Locate the Fuel Line and Purge Line spout off the right side of the Generator (below the rubber grommet for the Remote Start Wiring Harness and along side the 12Volt negative (-) ground connection. See [Exhibit 10](#).

**J.11** Slide the end of the RV purge line over the Generator Purge Line spout. See [Exhibit 10](#).

**J.12** Secure tightly with the RV Manufacturer provided purge line clamp.

**ATTENTION**

- In motorized RV applications, purge line will not be used and shall remain capped as received from NPS.

**J.13** Check connection for any leaks of fuel or vapors.

## K. Installation Overview

---

### WARNING

Before initially starting the Generator, verify that all of the below items are in line with Installation requirements:

### MANDATORY ACTION

- K.1** Is the Generator installed square in the Generator housing, with the Service Access Door facing outward guaranteeing easy accessibility for start/stop, breaker reset, emergency pull-start and servicing?
- K.2** Have all exhaust and air flow, Generator housing clearances and connections been installed and verified complete, in compliance with this Guide?
- K.3** Are the oil drain, air intakes and air outflows clearly unobstructed?
- K.4** Have the (6) Grade 8 installation bolts been installed and torqued to specs?
- K.5** Was the Generator box installed and sealed, to prevent any exhaust from entering RV, including all connections for electrical wiring, fuel, and exhaust?
- K.6** Ensure CO and smoke detectors are fully powered and operational prior to starting the Generator.
- K.7** Test and inspect all fuel connections and lines under pressure for leaks, and possible wear over time from contact points.
- K.8** Verify correct 12Volt circuit has been installed in accordance with the Manufacturer and NPS specifications.

### MANDATORY ACTION

**K.9** All NPS4500efi, NPS6000efi Generator come pre-filled with 10W40 break-in oil which must be replaced with 10W40 following initial twenty hours (20) of use.

### ATTENTION

- Inspect and verify engine oil is full prior to initial start. Failure to replace oil at initial twenty (20) hour interval or at specified maintenance intervals thereafter, may void NPS' Limited Warranty.

## L. Initial Start-up

---

L.1 Once all items in Section "K. Installation Overview" have been verified. Turn on the 12 volt master switch.

L.2 Locate the Start/Stop switch at the Control Panel located on the Generator inside the Service Access Door. See [Exhibit 3](#).

- Prime Generator Fuel Connections by depressing Stop/Prime button for ten (10) seconds.

(11) Then, depress and release the Start button, to start the Generator.

### ATTENTION

(12) If Generator cranks but does not Start, repeat the Priming process, if Generator still does not start, refer to section "M. Troubleshooting."

### WARNING

(13) **3 Upon starting the Generator, immediately inspect all fuel and electrical connections for possible leaks (or pooling) of fuel or exhaust and/or sparks or other electrical hazards:**

### ALERT

- Listen for excessive or irregular vibrations or rattling noises.
- **If any of the above items are heard or found shut-off the Generator immediately**, resolve the concern, re-start and verify concern is resolved while the Generator is running.
- If no concerns are found, verify 120Volt power is operational in the RV (a simple way to do this is to view the microwave inside the RV and see if the display is illuminated).
- If 120Volt power is operational, run Generator for a minimum of five (5) minutes before adding load such as the microwave or the air conditioners, allowing the Generator to properly warm-up and break-in.
- After five (5) minutes of smooth operation, and load has been applied, verifying proper operation shut off the Generator, and proceed with verification of the other start options.

(14) **4 Start Generator from inside the RV.**

- Depress the Start Switch inside the RV at the Remote Start Panel to verify the Generator connected correctly and is operating properly.

### WARNING

(15) **5 Upon starting the Generator, immediately inspect all fuel and electrical connections for possible leaks (or pooling) of fuel or exhaust and/or sparks or other electrical hazards:**

### ALERT

- Listen for excessive or irregular vibrations or rattling noises.
- **If any of the above items are heard or found shut-off the Generator immediately**, resolve the concern, re-start and verify concern is resolved while the Generator is running.
- If no concerns are found, shut down the Generator.

## L. Initial Start-up

---

**L.6 Start the Generator with the Hand-held Remote Start Keyfob, by depressing the Start button (the indicator light next to the Start button should illuminate), if operating properly, apply load and your NPS Generator is ready to be used**

- If the indicator light on the Hand-held keyfob does not illuminate when you push the button, try again. If it still does not illuminate or the Generator does not start, refer to section "M. Troubleshooting."

**MANDATORY  
ACTION**

**L.7 Upon completion of the installation, do a final walk around of the Generator install area, make sure area is clean and ensure all connections are tight and compartments are secured properly.**

## M. Troubleshooting

---

### Generator will not start:

#### M.1 Generator does not crank:

- Inspect battery voltage and connection to ensure adequate voltage and secure connections
  - if you have a low battery or poor connections, Generator will not turn over.
- Inspect the 12Volt Master Power "ON/OFF" Switch and verify it is in the "ON" position. See [Exhibit 14](#).
  - if battery voltage is adequate and Master 12Volt Power Switch is in the "ON" position.
- Attempt to start from another starting option.
  - If generator still will not crank, manually turn Automatic Choke to "FULL" and use pull start to start the Generator. See [Exhibit 3](#).
  - If still won't start, contact your dealer or NPS directly.

#### M.2 Generator cranks but does not fire:

- Inspect for adequate fuel,
  - if fuel is depleted or shut off it will not start.
- Inspect for spark,
  - if your spark plug has carbon build-up, is fuel saturated or if ignition wire is damaged/disconnected, it will not start.
- If generator has fuel and spark plug is intact and working properly and it still will not start, then contact your dealer or NPS directly.

#### M.3 Generator is running but not powering my RV:

- Check 30 amp breakers on the generator to see if they have tripped. If tripped, then reset,
  - If they will not reset, then contact your dealer or NPS.
- Check circuit breaker on Control Module (See [Exhibit 14](#)) to see if it has tripped. If tripped, then reset,
  - If it will not reset, then contact your dealer or NPS.
- Inspect the breakers and GFCI inside the RV to see if they have tripped. If tripped, then reset,
  - If they will not reset or still will not power, then contact your dealer or NPS.

**NPS offers full support for service, warranty and technical assistance through [www.NPSrvpower.com](http://www.NPSrvpower.com) or 1-866-407-1727 during normal business hours (9:00 am - 5:00pm MST) if assistance is requested outside normal business hours, leave a message or send an email and a team member will assist you as soon as possible.**

## M. Troubleshooting

---

**M.4 There are two Fault Indicator Lights on the Generator Control Panel: Overload Alarm Light and Oil Alert Light. See [Exhibit 3](#).**

- Overload Alarm Light blinks rapidly when the Generator is less than five percent (5%) overloaded,
  - Generator will continue running and outputting electricity.
- Overload Alarm Light stays on continuously when the Generator is more than five percent (5%) overloaded,
  - Generator will keep running but the Generator output will be cut off automatically within twenty (20) seconds.
- Overload Alarm Light stays on when the Generator is faulty (i.e. short circuit, low voltage, over voltage, engine over speed, etc.),
  - Generator will keep running but the Generator output will be automatically cut off.
- Oil Alert Light blinks when the oil level is too low. In this case, the engine will shut down automatically and the Oil Alert Light will remain illuminated.

**NPS offers full support for service, warranty and technical assistance through [www.NPSrvpower.com](http://www.NPSrvpower.com) or 1-866-407-1727 during normal business hours (9:00 am-5:00pm (MST)) if assistance is requested outside normal business hours, leave a message or send an email and a team member will assist you as soon as possible.**

## M. Troubleshooting

---

### M.5 Hand-held Remote-Start Keyfob is not working:

- Verify the problem is not with the Generator by starting the Generator using another starting option:
  - If Generator will start from another starting option but Hand-held Remote Start Keyfob still will not start or stop the Generator, then the Keyfob signal may be the problem.
- Re-set Keyfob signal by performing a Signal Match:
  - To match signals connect the Generator with the RV battery source, turn the Master 12 Volt Power Switch, inside the Generator Service Access Door, to the "ON" position. See [Exhibit 14](#).
  - Press the Signal Match Set Button on the Remote Control Module and hold it for more than three (3) seconds, until the Signal Match Indicator Light on the Remote Control Module stays on constant.
  - Release the Signal Match Set Button and press the "STOP" button on the Keyfob (at this moment, the Signal Match Indicator Light on the Remote Control Module will blink one time and then stay on constant).
  - Release the "STOP" button on the Keyfob and press the "START" button on the Keyfob (at this moment, the Signal Match Indicator Light on the Remote Control Module will blink one time and then stay on constant).
  - Release the "START" button on the Keyfob, press and hold the Signal Match Set Button on the Remote Control Module until the Signal Match Indicator Light on the Remote Control Module is off.
  - Start the Generator by pressing "START" on the Keyfob, then stop the Generator by pressing "STOP" on the Keyfob to verify the signals have matched. If the match is not made, repeat the above procedure, until the Keyfob and Generator wireless signals are successfully matched.
- If your Hand-held Remote-Start Keyfob still does not work, then contact your dealer or NPS directly.

**NPS offers full support for service, warranty and technical assistance through [www.NPSrvpower.com](http://www.NPSrvpower.com) or 1-866-407-1727 during normal business hours (9:00 am-5:00pm (MST)) if assistance is requested outside normal business hours, leave a message or send an email and a team member will assist you as soon as possible.**

## **N. Exhibit List**

---

- Exhibit 1: ECI Fuel System Tag**
- Exhibit 2: NPS Generator**
- Exhibit 3: Generator Components Located within the Service Access Door**
- Exhibit 4: Generator Base**
- Exhibit 5: Generator Installation Kit**
- Exhibit 6: Exhaust Kit**
- Exhibit 7: Fifth-Wheel Generator Exhaust Assembly**
- Exhibit 8: Fifth-Wheel Exhaust Placement**
- Exhibit 9: Bumper-Pull Exhaust Assembly Configuration**
- Exhibit 10: AC Power and Fuel Connections**
- Exhibit 11: Electrical Components**
- Exhibit 12: Wiring Harness - Remote Start Panel Connections**
- Exhibit 13: Wiring Harness - Wiring Harness Connections**
- Exhibit 14: Wiring Harness - Connections at Generator**
- Exhibit 15: Wiring Diagram**
- Exhibit 16: Generator Installation Bracket Floor Template**

# Quick Reference Contacts and Service

---

N.P.S. Company, LLC

Western HQ:

5252 W. Industrial Drive

Unit 2

Hurricane, UT, 84737

Eastern HQ:

1827 County Road 6

Elkhart, IN, 46514

Service and Warranty Information Toll Free: (866) 407-1727

[www.npsrvpower.com](http://www.npsrvpower.com)

[npsclaims@npsrvpower.com](mailto:npsclaims@npsrvpower.com)

# Exhibit 16 - Generator Installation Bracket Floor Cut-out Template (measurements are in millimeters)

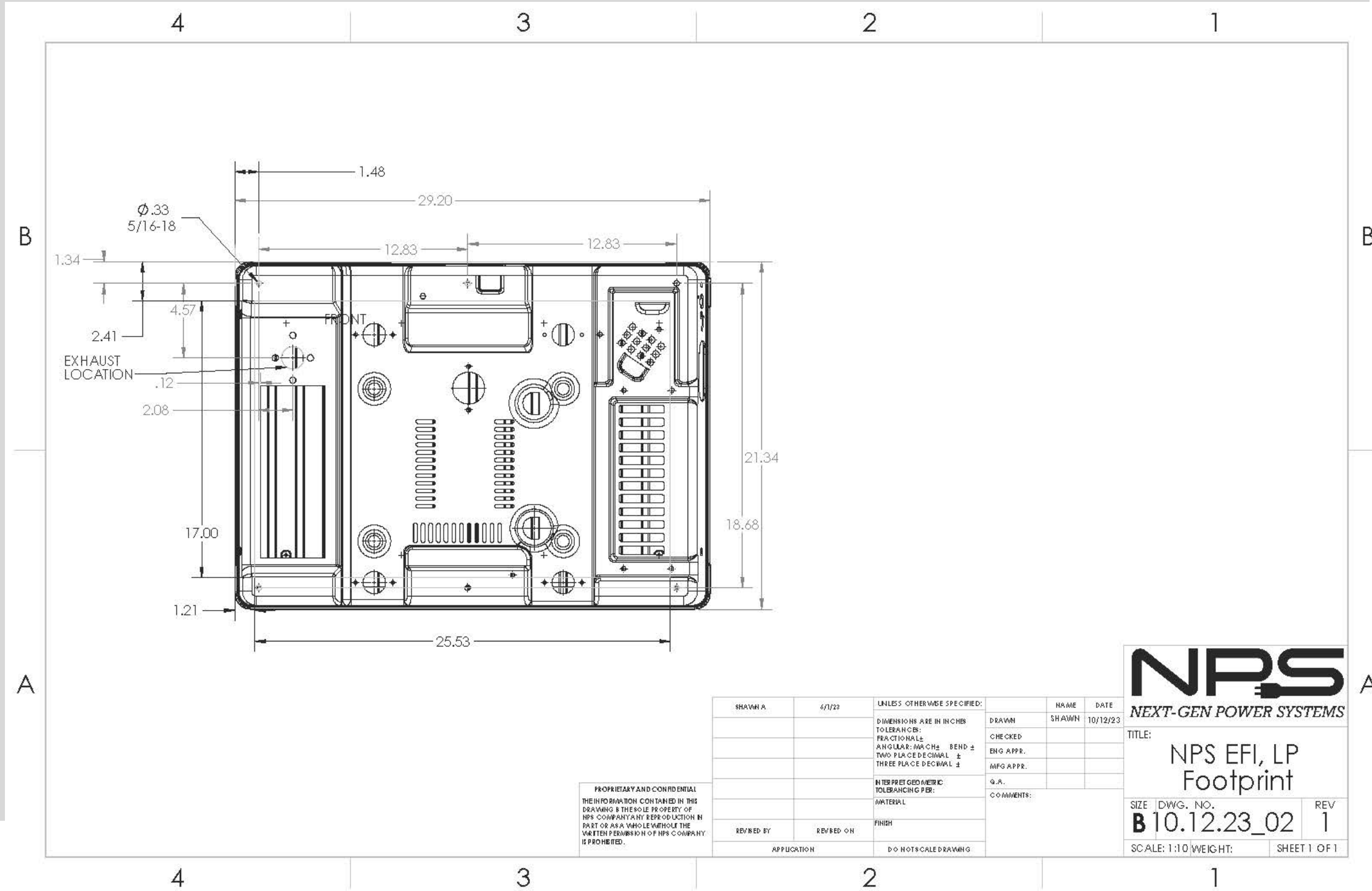

PROPRIETARY AND CONFIDENTIAL  
 THE INFORMATION CONTAINED IN THIS  
 DRAWING IS THE SOLE PROPERTY OF  
 NPS. UNAUTHORIZED REPRODUCTION IN  
 PART OR AS A WHOLE WITHOUT THE  
 WRITTEN PERMISSION OF NPS COMPANY  
 IS PROHIBITED.

SHAWN A	6/1/23	UNLESS OTHERWISE SPECIFIED:	NAME	DATE
		DIMENSIONS ARE IN INCHES	SHAWN	10/12/23
		TOLERANCES:	DRAWN	
		FRACTIONAL: ±	CHECKED	
		ANGULAR: MA CH ± BEND ±	ENG APPR.	
		TWO PLACE DECIMAL ±	MFG APPR.	
		THREE PLACE DECIMAL ±	Q.A.	
		INTERPRET METRIC	COMMENTS:	
		TOLERANCING PER:		
		MATERIAL		
		FINISH		
REVISED BY	REVISED ON			
		APPLICATION		

**NPS**  
 NEXT-GEN POWER SYSTEMS

TITLE:  
 NPS EFI, LP  
 Footprint

SIZE DWG. NO. REV  
**B** 10.12.23\_02 1

SCALE: 1:10 WEIGHT: SHEET 1 OF 1