Pro Series 24V/36V User Manual



EPOCH BATTERIES

Lithium Iron Phosphate Battery with Smart Monitoring

Epoch Batteries

Address: 164 Andrew Drive, Stockbridge GA 30281, GEORGIA, USA

Email: support@epochbatteries.com

Web: www.epochbatteries.com

Contents

1. Safety	4
1.1 Statement	4
1.2 Specification	4
1.3 Critical safety info.	4
1.4 Battery maintaining	5
1.5 Waste disposal	6
2. Installation	6
2.1 Tools and Equipment	6
2.2 Battery placement	6
2.3 Battery supporting materials	7
3. Introduction to Epoch Pro series batteries	8
3.1 Main features	8
3.2 Product appearance.	8
3.3 Functional characteristics	14
3.4 Heating function	15
4. Parallel connection of batteries	15
4.1 Introduction	15
4.2 Parallel usage	16
4.5 Battery communication	17
4.5.2 Networking method:	18
5. Charging requirements	19
5.1 AC-DC charger	20

5.2 Photovoltaic charging	20
5.3 Charging with an AC generator through a DC-DC charger	20
5.4 Recommended charging voltage	20
5.5 Passive balance function	20
6. <i>Battery recycling</i>	21
7. <i>Transportation and Storage</i>	21
8. <i>Warnings and reminders</i>	21



1.Safety

1.1 Statement

Please read this manual carefully before installation, operation, and maintenance, and pay attention to various warning signs and statements on the equipment. After reading this manual, please keep it properly for future reference.

1.2 Specification

This manual contents using the following symbols should be paid special attention to during operation.

Symbol	Statement
	Attention, caution, warning: Reminder of precautions during operation
	Danger, Reminder that there is a risk of electric shock during operation and protective measures need to be taken
	Explanation or reminder, Matters that require special explanation or reminder

1.3 Critical safety info.

Before installing, operating, or maintaining the battery, the following operating and maintenance instructions must be read.

Before installing

- It is very important and necessary to carefully read the user manual before installing or using the battery. Failure to follow any instructions or warnings in this document may result in electric shock, serious injury, or damage to the battery and the entire system.
- Before connecting the battery pack to your device, check the voltage and ensure that they are within the limits of your device specifications. Failure to comply with these specifications will void your warranty.

During installation:

- Personnel familiar with the electrical specifications of their country or region are required to install battery packs. For optimal safety, please follow the steps described in this manual.

Battery operation:

- ① Prohibit connecting batteries to different types of batteries;
- ② Do not use faulty or mismatched chargers to charge the battery;
- ③ The environmental conditions specified in the product specification must be followed;
- ④ If the battery is found to be deformed, abnormally hot, or emitting an odor, please immediately cut off the power and stop using it.

1.4 Battery maintaining

① Professional personnel should take care of the charging operation, ensure good contact between the plug and socket during the charging process, ensure normal operation of the charging equipment, and ensure good contact at all connection points of the battery pack. If there is an abnormality, it needs to be repaired before charging;

② If there is a large amount of dust, metal shavings, or other debris on the upper cover and pole of the battery pack, clean it with Vacuum cleaner a timely manner to avoid using water or objects soaked in water for cleaning;

③ Try to avoid splashing water or other conductive objects onto the battery cover and pole during charging and discharging, such as when exposed to heavy rain for use;

④ Estimate the charging and discharging time of the battery or battery pack based on its actual usage status. Pay attention to observing whether there are any abnormalities in the battery or battery pack at the end of charging and discharging, such as voltage difference issues;

⑤ Check whether the conductive strip, voltage collection terminal, and other nodes are loose, detached, rusted, or deformed, ensuring that the batteries used in parallel connection are fixed and reliable (once/3 months);

1.5 Waste disposal



Please handle packaging and replace components in accordance with the laws and regulations of the country or region where the battery pack is located. Do not mix batteries with daily life, dispose of garbage together.

2. Installation

2.1 Tools and Equipment

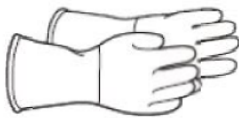

insulating gloves



Safety shoes



Tool

2.2 Battery placement

Gently place the battery pack face up on the support surface, do not lay it on its side or upside down, and do not place any covers above the pack. The schematic diagram of battery pack placement is shown in Figure 3

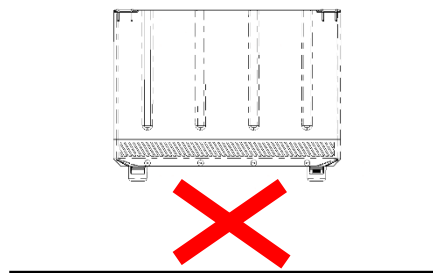
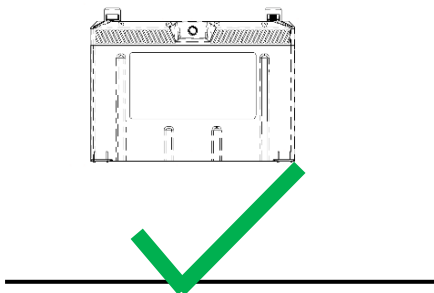

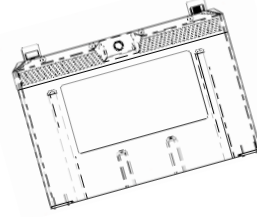
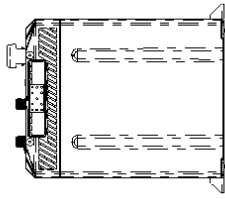

Figure 1 Installation and Placement Diagram

2.3 Battery supporting materials

Table 1: Material List

SN	Material name	Chart	QTY/p c	SPEC
1	Inter-communication cable		1	5000mm/1000mm long, M12 circular, communication interface at both ends.
2	Battery		1	25.6V60Ah or 25.6V100Ah or 38.4V100Ah
3	Screw		2	M8 * 16 stainless steel screw

3. Introduction to Epoch Pro series batteries

3.1 Main features

- a. LiFePO₄ chemistry - providing excellent safety and lifespan
- b. High reliability
- c. Maintain consistent performance over a wide temperature range
- e. With higher heat dissipation effect, it can maintain high current charging and discharging of the battery for a longer time
- f. The communication function enables the battery to communicate with external devices through CAN, enabling better battery management.

3.2 Product appearance.

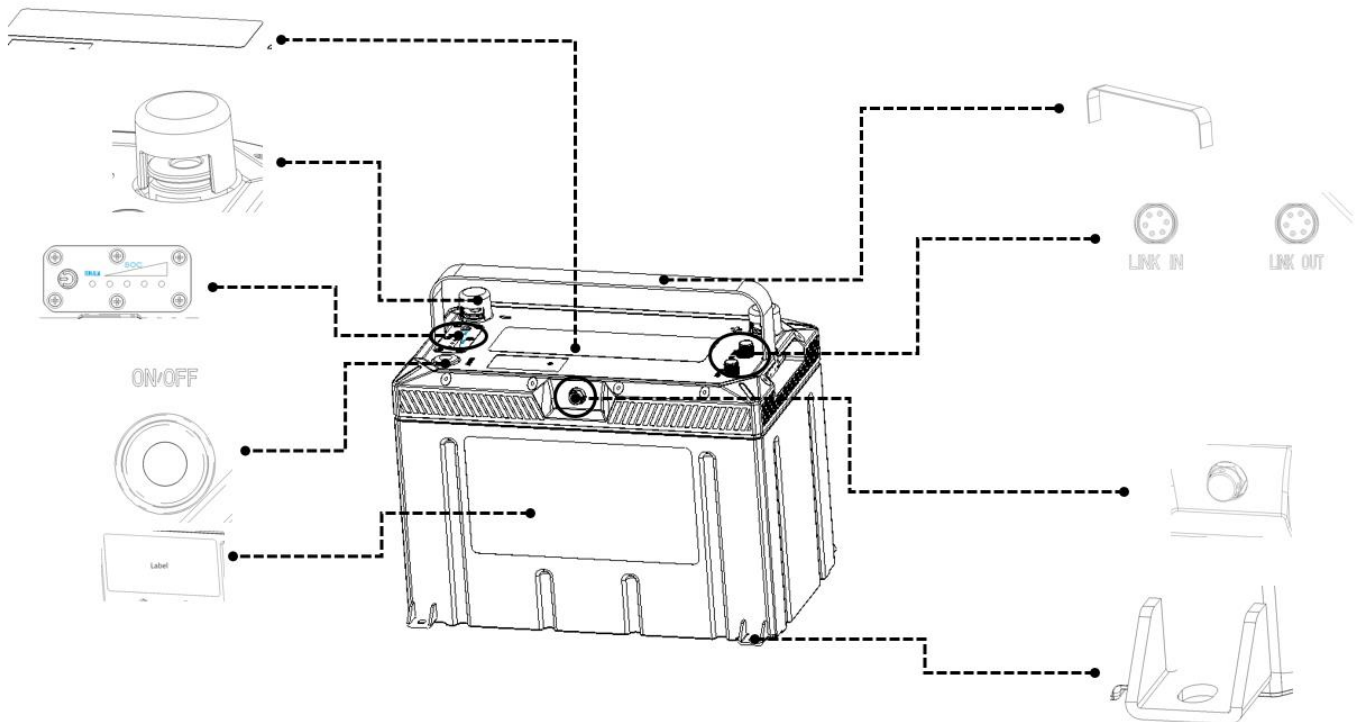
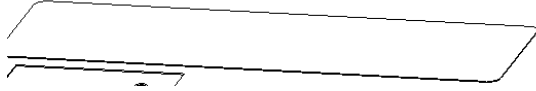
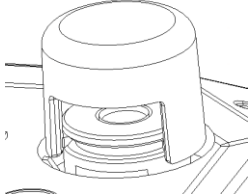
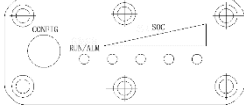



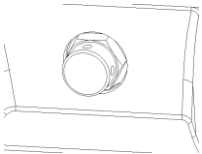

Figure 2 Battery Appearance

No.	Component Description	Name	Statement
1		Fin	Disperse the heat inside the battery, be careful not to touch it with your hands.
2		Pole	M8 Terminal.
3		Display Panel	Check the soc. running light to preliminarily determine whether the battery operates normally.
4		Power Switch	When the battery is not used for a long time, it can be disconnected to reduce self-consumption.
5		Label	Carefully read the label and use the battery correctly according to the label content
6		Handle	Convenient handling of batteries.
7		Port	Battery to battery communication, battery to external communication.
8		Pressure relief valve	IP67 to prevent lithium batteries from exploding in special circumstances.



9		Bracket	Convenient for fixing the battery on the ground. (Only 24V60Ah have)
10		Tray	Used to secure battery. (24V100Ah and 36V100Ah have)
11		Strap	Used to tighten the battery and tray together.

Table 1: Component Description

1. Heat sink

The heat sink is a battery cooling component, and rapid heat dissipation is beneficial for extending the battery life. At the same time, the heat sink is a hot decoration that cannot be touched by hand during battery use to avoid burns.

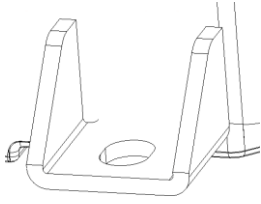
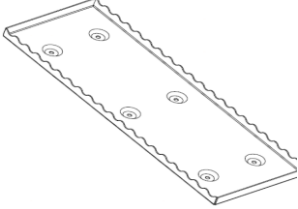
2. Pole terminal

Each battery has a positive terminal and a negative terminal. During use, be sure to identify and avoid reversing the positive and negative poles. After connecting the power line to the pole terminal, cover it with a protective cover to avoid short circuits.

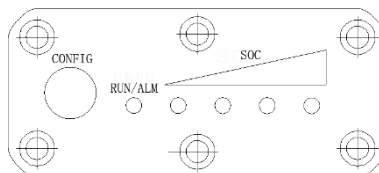

3. Display panel



The battery display panel has 1 run/alm light, 4 SOC indicator lights, and 1 config button: the usage method is as follows:









RUN/ALM: One red light, one green light, displayed in green when the battery is normal; When there is a battery failure alarm or protection, it will display in red.

Table 2: Explanation of indicator lights

Indicator light 	Always on during charging or discharging	Flashing during Blink 1
Indicator light 	Always on when there is a malfunction	

Blinking mode	Lighting time	Off time
Blink 1	0.25s	3.75s
Blink 2	0.5s	0.5s

SOC indicator lights: 4 green lights, representing different SOC according to different lighting methods. One lamp represents 25% SOC

Status	Charge				Discharge			
	L1	L2	L3	L4	L1	L2	L3	L4
SOC								
$0 \leq \text{SOC} \leq 25\%$	Blink2	off	off	off	On	off	off	off
$25 < \text{SOC} \leq 50\%$	On	Blink2	off	off	On	On	off	off
$50 < \text{SOC} \leq 75\%$	On	On	Blink2	off	On	On	On	off
$75 < \text{SOC} \leq 100\%$	On	On	On	Blink2	On	On	On	On

Config button:

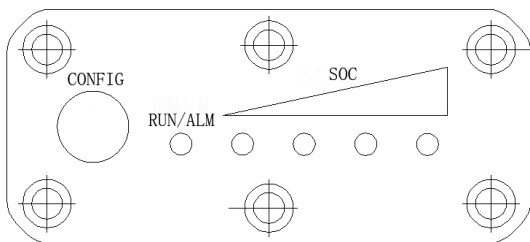

Usage method:

- ① Press 1s to view battery SOC;
- ② Press for more than 10 seconds to match the address of the battery and form a network;
- ③ Press for 3 seconds to unlock the networking system. For detailed purposes, please refer to the networking function.

4. Battery switch

Power switch: The battery power switch is used to turn the battery on or off. When the battery is in the ON state, it indicates that the battery BMS is in a normal state and can be charged, discharged, and connected to Bluetooth;

When the battery is in the OFF state, it indicates that the battery is in a shutdown state, and cannot be charged or discharged, and cannot connect to the battery Bluetooth; The battery enters a sleep state. When the battery is not used for a long time, placing the switch in the OFF state can reduce BMS power consumption.

★ The lithium battery is equipped with an intelligent BMS, which is designed to better protect the battery cell. From the OFF state to the ON state, the BMS performs a self-check, and the self-check time does not exceed 10 seconds. Therefore; the startup time is normal within 10 seconds.

Config button: You can check the battery SOC, which is used to match the master address when the battery needs to be networked and communicate with the outside world.

5. Label

Labels are performance parameters displayed. During use, it is important to match the corresponding charger and load according to the label parameters to avoid battery failure.

6. Handle

The handle is used to bear the weight of the battery. When lifting the battery, pay attention to observing the stability of the handle to avoid the battery falling off;

7. Communication port

There are two communication ports: one is Link in and the other is Link out. Pay attention during use.

When the battery needs to communicate with external devices, a Link in needs to be connected;

A: Schematic diagram of single battery usage

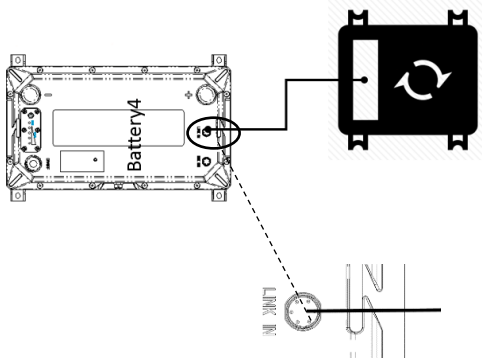

B: When multiple batteries are used in parallel, the external device communication line needs to be connected to the battery Link in;



8. Pressure relief valve

The waterproof grade is IP67, because the battery is heating during charging and discharging, which leads to thermal expansion. Adding a pressure relief valve can prevent the air pressure inside the battery box from rising, resulting in dangerous accidents. Make sure that there is no other objects around the pressure relief valve.

9. Installation bracket

Install the bracket to facilitate the installation of battery in vehicles. It is recommended to use M6 stainless steel screws to secure the battery.



10. Tray

Assist in securing the battery to the vehicles. It is recommended to use cross recess pan head screw to secure the battery.

11. Strap

Tie the battery tray together to ensure that the battery do not shake randomly.

3.3 Functional characteristics

Item	2460	24100	36100
Nominal voltage	25.6V		38.4V
Nominal energy	1536Wh	2560Wh	3840Wh
Nominal capacity	60Ah	100Ah	100Ah
Internal resistance@1khz AC	≤30mΩ		
Allowed MAX. charge current@25°C	60A	100A	100A
Allowed MAX. discharge current@25°C	80A	120A	120A
Recommend charge current	30A	50A	50A
Recommend discharge current	30A	100A	100A
Peal /Surge current limit	200A-3s	500A-3s	500A-3s
Short circuit current	800A-500μs	1200A-500μs	1200-500μs

3.3.1 First use

- ① Observe that there are no signs of the battery being disassembled;
- ② When the battery leaves the factory, the power switch will be turned off and in the OFF state;
- ③ Before using the battery, it is necessary to turn the switch to the ON state, and the LED display light

will be on.

3.3.2 Communication port

- ① 2 * Communication ports with CAN communication;
- ② You can upgrade the battery firmware through the communication port;
- ③ It can communicate with other devices through the communication port.

3.3.3 Power Switch

When the battery is in transportation or long-term storage, it can be turned off, which is of extremely low self-consumption, ensuring that the battery can be stored for a long time without being discharged. At the same time, it is beneficial to improve the safety of the battery.

3.4 Heating function

The battery has a low-temperature heating function. When in cold weather, the battery is equipped with a built-in heater. When a charger is inserted, the built-in heater will automatically warm up the battery to 10°C and then switch to charging mode.

4. Parallel connection of batteries

4.1 Introduction

The Pro-Series battery allows multiple batteries to be connected in parallel (not support connected in series), this allows us to increase the capacity of the battery system. For example, four 25.6V100Ah batteries can be connected in parallel to form a 25.6V400Ah battery system.

When multiple sets of batteries are connected in parallel at the same time, in addition to external power lines, communication lines can be connected between the batteries, and internal communication between the batteries can better obtain battery information. One battery can be set as the master battery, and the other batteries can be set as the slave battery. The master collects all information about other slave batteries, and

can communicate with external devices such as inverters, display screens, MPPTs, etc.

Before connecting batteries in parallel, it is necessary to pay attention to:

- a). The batteries must be of the same model. Different models, different capacities, and different voltage platforms, and parallel connection is not allowed;
- b). Ensure that all parallel wires are of the identical length;
- c). 0.5C charging is recommended, that is, charging current=rated capacity of battery * 0.5C;
- d). before connecting the batteries in parallel, the voltage of each group of batteries must remain highly consistent. It is recommended that the voltage difference between battery packs be:

*Voltage difference < 500mV

When batteries are connected in parallel, it will be charged and discharged as a whole system.

4.2 Parallel usage

A maximum of 16 batteries can be used in parallel. Before connecting batteries in parallel, a multimeter needs to be used to test the voltage between the positive and negative terminals of the battery. You can also check the battery voltage through the Bluetooth app to ensure that the voltage between the batteries does not exceed 0.5V, which can be connected in parallel. If the voltage between the batteries exceeds 0.5V, each battery needs to be fully charged separately, left for 1 hour, and then used in parallel.

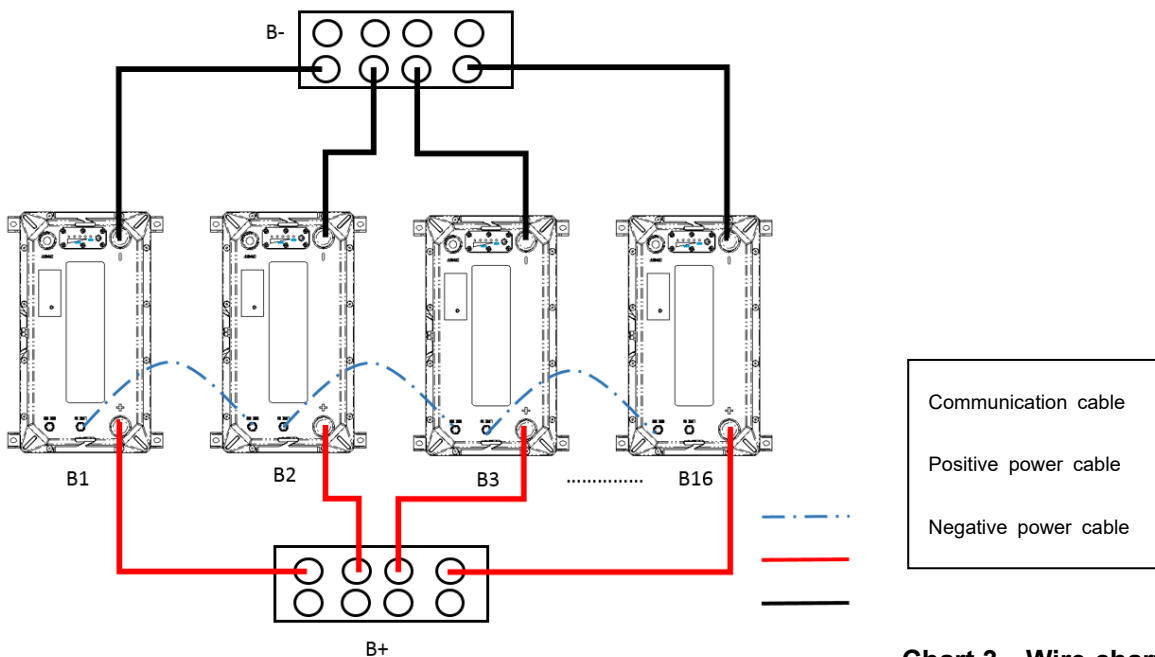
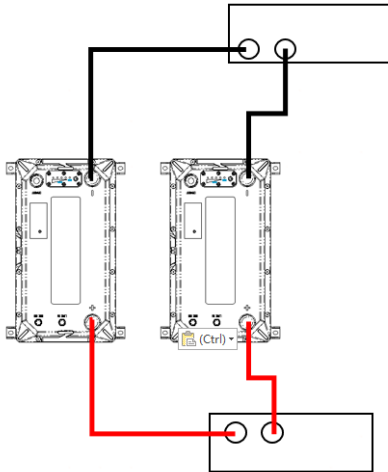
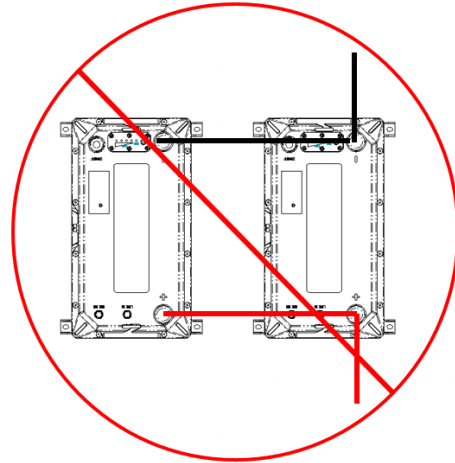

Chart 3: Wire chart

For example, two 25.6V 60Ah are used in parallel



! Do not output positive and negative poles on the same battery, which may damage the battery.



System voltage: 25.6V

System capacity: 60Ah + 60Ah = 120Ah

4.5 Battery communication

4.5.1 Communication terminal connection

The Pro Series batteries have the function of communication networking between batteries. When communication with external devices is needed, the networking function can be used to enable the battery to summarize information. The battery can be used alone or used for communication networking, which is more prominent in some intelligent devices. When using this function, it is important to understand its purpose and carefully read the following instructions for correct operation.

The battery includes a Controller Area Network (CAN) bus communication interface. Two circular M8 DIN connectors are located at the top of the battery to connect one battery (Link in) to another battery (Link out) using a CAN bus cable in a simple daisy link wire method.

Communication line connection method:

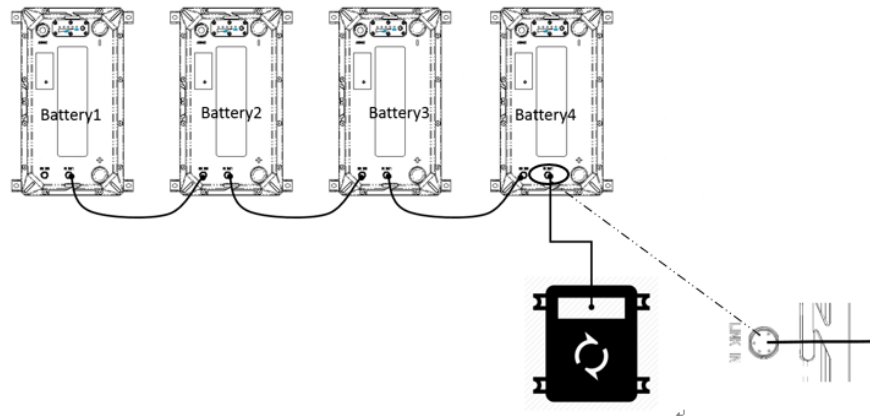

User can use an external communicated cable (optional) to connect to batteries and other device via CAN bus. This allows for communication between the battery and the load or charger, making it more efficient to use the battery. This is also beneficial for understanding battery faults. If you have more questions about the CAN bus, please contact EPOCH BATTERIES for technical support.

For normal battery operation, the CAN bus function is not mandatory. The battery can automatically operate and protect itself; it does not require any CAN bus communication or external devices (such as external controllers) or other CAN bus connected batteries to operate. Retain the two black covers installed on the two M12 connectors to protect them from environmental influences when not in use.

4.5.2 Networking method:

After connecting the battery through the communication cable, it is necessary to use the Bluetooth connection method through the smart APP to network the battery.

1. Equipment operation:

- ① Wiring: When all batteries are turned off, use the power line to connect the batteries in parallel; Please refer to this chapter<4.2 Parallel Use>.
- ② The battery connected to external devices serves as the first battery (Battery1), and we define this battery as the master, while other batteries are the slaves;
The LINK OUT of master battery1 is connected to the LINK IN of slave battery2,
Connect the LINK OUT of slave battery2 to the LINK IN of slave battery3; and so on.

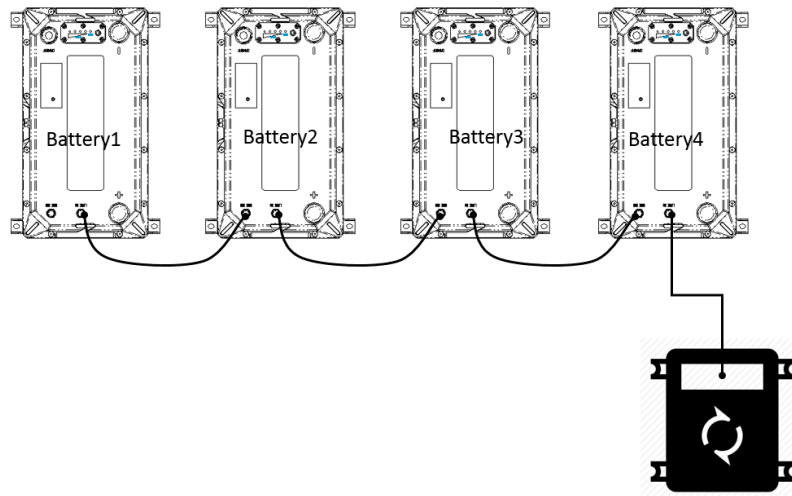

- ③ Turn on the battery power switch: switch from OFF to ON
- ④ Matching address: After pressing the master battery1 config button for 10 seconds, the indicator light will start running. After all the indicator lights are off, it means that the internal address allocation of the battery is completed;

! Attention: The battery cannot be connected in series mode; The matching address must be selected battery1 as the master, long press and hold its config button for 10s. Can not select and press the config button of other slave batteries. This step is particularly important as improper operation may result in battery networking failure.

5. Charging requirements

We recommend using a charging source with specific lithium charging settings to meet the following charging requirements to achieve the optimal performance and lifespan of EPOCH BATTERIES series batteries.

Model	Recommended Charge Voltage	Recommended float voltage	Max. Charge Current	Recommended Charge Current	Operation Temperature
48V	56.8V	55.2V	1C	0.5C	Charge: 0~60°C Discharge: -20~65°C
36V	42.6V	41.4V			
24V	28.4V	27.6V			
12V	14.2V	13.8V			

Note: Batteries with heating function need to be heated before switching to charging mode

5.1 AC-DC charger

Check if the AC-DC battery charger you plan to use has a dedicated lithium battery charging setting that meets the above charging requirements. Many battery chargers are only designed to charge Lead–acid battery and may not have appropriate lithium battery charging settings.

5.2 Photovoltaic charging

Check if the solar regulator you plan to use has a dedicated lithium battery charging setting that meets the above charging requirements. The Pro Series batteries can be charged using a solar regulator without lithium battery charging settings. However, it must be set to charge no more than 29.2V (for 24V60Ah and 24V100Ah) or 43.8V (for 36V100Ah) for a single battery. After the battery is fully charged, please turn to the recommended floating voltage.

5.3 Charging with an AC generator through a DC-DC charger

Check if the DC-DC charger you plan to use has a dedicated lithium battery charging setting that meets the above charging requirements. You can use a DC-DC charger without lithium battery charging settings to charge Pro series batteries. However, it must be set to charge no more than 29.2V (for 24V60Ah and 24V100Ah) or 43.8V (for 36V100Ah) for a single battery, and then it must be turned off after the Pro Series battery is fully charged. After the battery is fully charged, please turn to the recommended floating voltage.

5.4 Recommended charging voltage

We strongly recommend a dedicated charger for lithium-ion batteries to better fully charge the battery. At the same time, according to the actual situation, AGM chargers can also be used to charge the battery, which can achieve varying degrees of effect.

5.5 Passive balance function

When the battery is charged close to SOC 100%, due to the chemical characteristics of lithium batteries, the voltage difference between the cells will gradually expand. In order to ensure that each cell has the same capacity, slightly higher capacity cells will be consumed, which can allow the remaining cells to catch up.

6. Battery recycling

EPOCH BATTERIES® Pro Series lithium-ion batteries are recyclable and should not be treated as household waste or landfill waste. If you need assistance in recycling batteries, please contact your dealer or EPOCH BATTERIES.

7. Transportation and Storage

- During transportation, there should be no severe vibration, impact, or compression, and it should be protected from sunlight and rain.
- Handle with care during loading and unloading, and strictly prevent falling, rolling, and heavy pressure.
- The battery should be stored in a dry, clean, dark and well ventilated indoor environment for a long time.

The recommended storage temperature range is 15~35 °C.

- The storage area is free of harmful gases, flammable and explosive materials, and corrosive chemicals.
- Batteries should be stored and transported at temperatures close to 50% SOC.
- If not used for a long time, the battery needs to be charged every 6 months according to the specifications.
- It is strictly prohibited to collapse, and the stacking should not exceed 6 layers, with the surface facing upwards.

8. Warnings and reminders

Please carefully read the battery specifications or instructions before use. Improper use may cause the battery to heat up, catch fire, rupture, damage, or decrease capacity. EPOCH BATTERIES shall not be responsible for any accidents caused by not following our operating instructions.

Warning!

- The battery must be kept away from heat sources, high voltage, and directly exposed to sunlight.
- Do not throw the battery into water or fire.
- Do not invert the two terminals when using the battery.
- Do not connect the positive and negative poles of the battery to the conductors.

- Do not strike, throw, or step on the battery.
- Do not disassemble the battery without the manufacturer's permission and guidance.
- Do not mix batteries of different capacities and brands;

Reminder:

- It is recommended to fully charge the battery every month to correct the battery SOC.
- When the battery is over discharged, please charge the battery in a timely manner (≤ 2 days).
- Please use a dedicated lithium battery charger to charge the battery.
- Please stop using the battery when it emits odor, heat, deformation, or any abnormalities occur
- Please place the battery away from children or pets.
- If the battery pack electrolyte leaks, please avoid contact with liquids or leaked gases. If the battery pack electrolyte leaks, please take the following steps immediately:
 - ① Inhalation of gas: Evacuate personnel from the contaminated area and seek medical attention as soon as possible.
 - ② Eye contact: Rinse eyes with water for 15 minutes and seek medical attention as soon as possible.
 - ③ Skin contact: Thoroughly rinse the exposed area with soap and water to ensure there are no chemicals or soap residues on it, and seek medical assistance as soon as possible.
 - ④ Swallowing: Try to induce vomiting and seek medical attention as soon as possible.
 - ⑤ Fire: Please use carbon dioxide fire extinguishers instead of liquid fire extinguishers to extinguish the fire.