

# DE50F4

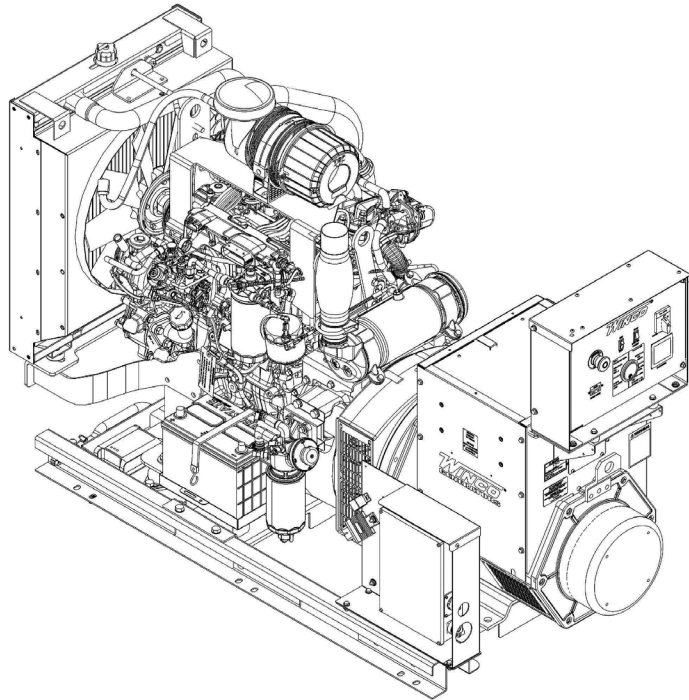

Designed, engineered, and manufactured in our facility located in Le Center, Minnesota, equipped with modern engineering, fabrication and assembly capabilities.

### Full Load Tested

Every generator is 100% load tested in-house.

### Key Start

The key start assembly can easily be rotated to three sides of the unit. Allowing the unit to be installed in a convenient position according to your specs.

### FPT Tier IV Engine

We think a little more engine is key for long life and quick responses to load changes. There isn't Urea or a need to shutdown for regens with this FPT F5 series engine with DOC-PMCAT.



VOLTS	PF	STANDBY			PRIME		
		WATTS	KVA	AMPS	WATTS	KVA	AMPS
120/240 1-PH	1.0	45,000	45.0	187	40,500	40.5	168
120/208 3-PH	0.8	47,000	60.0	166	43,200	54.0	150
120/240 3-PH	0.8	47,000	60.0	144	43,200	54.0	130
277/480 3-PH	0.8	47,000	60.0	72	43,200	54.0	65
346/600 3-PH	0.8	47,000	60.0	58	43,200	54.0	52

MOTOR STARTING (CODE G)	20 HP
DBA @ 7 METERS FULL LOAD	-
TOTAL HARMONIC DISTORTION	< 5%
MAIN CIRCUIT BREAKER	CUSTOMER SUPPLIED
120/240 1-PH	160-230A
120/208 3-PH	150-200A
120/240 3-PH	130-180A
277/480 3-PH	60-90A
346/600 3-PH	50-70A
BONDED NEUTRAL	YES

REQUIRED BATTERY <sup>(1)</sup>	GROUP 24 650 CCA
FORKLIFT POCKETS	STANDARD
ASSEMBLED IN	USA
EPA APPROVED	TIER IV
CARB APPROVED	TIER IV
TÜV CERTIFICATION	
CSA	YES
UL2200	YES
UNIT WARRANTY <sup>(2)</sup>	1 YEAR/2,000 HOURS

# ENGINE

ENGINE BRAND	FPT
ENGINE MODEL	F34TE1W.S550
ENGINE STARTER	12V ELECTRIC
ENGINE SPEED	1800 RPM
ENGINE CYLINDERS	4
ENGINE HP	50
FREQUENCY	60 HZ
ALTERNATOR	95 AMPS, 12V
FLYWHEEL	11.5"
ROTATION	CCW
ASPIRATION	TURBOCHARGED
BORE/STROKE	99 mm x 110 mm
DISPLACEMENT/TYPE	3.4L
EXHAUST FLOW	0.41 CFM

EXHAUST OUTLET	4"
RECOMMENDED OIL <sup>(3)</sup>	5W-40 SAE
OIL CAPACITY	8.5 QT
INJECTION PUMP	BOSCH CP4.1
GOVERNOR	ELECTRONIC
COMPRESSION RATIO	16.5:1
FAN TYPE	PUSHER
INTAKE AIR CONSUMPTION	0.36 CFM
COOLANT CAPACITY	5.1 GAL
RADIATOR COOLING AIR	6,865 CFM
STARTING AIDES	GLOW PLUGS
START TEMP NATURAL W/ AIDES	5° F
START TEMP W/ BLOCK HEATER <sup>(4)</sup>	-13° F

# FUEL

TYPE	ASTM D975 NO-2D DIESEL
OPTIONAL FUEL TANK <sup>(5)</sup>	47 GAL
CONTAINMENT	110%
TANK DIMENSIONS	70.5" x 30" x 18"
FULL LOAD RUN TIME <sup>(6)</sup>	14 HOURS

FUEL CONSUMPTION	GAL/HR
100%	4.16
75%	3.35
50%	2.20
25%	1.33

# GENERATOR END

GENERATOR END BRAND	STAMFORD
GENERATOR END MODEL	UCI224E
WINDING	311 - 12 LEAD
VOLTAGE REGULATION	AVR +/- 1%
AVR TYPE	AS440
TEMPERATURE RISE	125/40°C
TYPE	REVOLVING FIELD
BRUSHLESS	YES
SPEED	1800 RPM

ROTOR	2/3 PITCH
WINDINGS	100% COPPER
STATOR WINDING	DOUBLE LAYER CONCENTRIC
COUPLING	DIRECT/FLEXIBLE DISC
BEARINGS	SINGLE (MAINTENANCE FREE)
EFFICIENCY PEAK	89.6
INSULATION	CLASS H
INGRESS PROTECTION	IP23

# DERATES

ABOVE SEA LEVEL	
6,561 FT	10%
9,842 FT	20%

AMBIENT TEMPERATURE	
>104°F	3% EVERY 10°F

# ROCKER MANUAL START

## ENGINE

LOW OIL PRESSURE	SHUTDOWN
HIGH COOLANT TEMP	SHUTDOWN
OVER CRANK	SHUTDOWN
CAN ECU	DISPLAY/SHUTDOWN

## GENSET

VOLTAGE (L-L)	DISPLAY
---------------	---------

# OPTIONAL DSE 7310 MKII CONTROLLER

## ENGINE DISPLAY/PROTECTION

ENGINE RPM	YES
LOW OIL PRESSURE	YES
HIGH COOLANT TEMP	YES
LOW COOLANT	YES
OVER/UNDER SPEED	YES
OVER CRANK	YES
CAN ECU SHUTDOWN	YES

## GENSET DISPLAY/PROTECTION

VOLTAGE (L-N & L-L)	YES
OVER/UNDER VOLTAGE	YES
FREQUENCY	YES
OVER/UNDER FREQUENCY	YES
AMP DISPLAY/SHUTDOWN	YES
PHASE IMBALANCE	DISABLED
KW, KVA, KVARH DISPLAY	YES
KWH, KVAH, KVARH DISPLAY	YES
GENERATOR PHASE SEQUENCE	OPTIONAL

## ADDITIONAL DISPLAYS/PROTECTIONS

EXTERNAL E-STOP	YES
BATTERY VOLTAGE	YES
BATTERY OVER/UNDER VOLTAGE	YES

## COMMUNICATIONS

USB CONNECTABLE	YES
RS232/RS485	YES
NFPA ANNUNCIATOR	OPTIONAL
REMOTE DISPLAY PANEL	OPTIONAL
ETHERNET/MODEM	OPTIONAL

## ADDITIONAL FEATURES

AUDIBLE ALARM	YES
ENGINE EXERCISER	YES
MAINTENANCE INTERVAL TIMER	OPTIONAL
LOAD SHEDDING/DUMMY	OPTIONAL
CONFIGURABLE INPUTS	4 (EXPANDABLE)
CONFIGURABLE OUTPUTS	4 (EXPANDABLE)
EVENT LOG	250

# SHIPPING

SHIPPING DIMENSIONS (L x W x H)	89" x 43" x 72"
SHIP WEIGHT (Without Tank)	2,186 LBS
FREIGHT CLASS	70

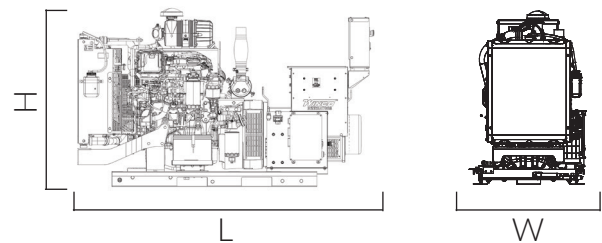

# OPTIONAL ACCESSORIES

BATTERY	GROUP 24 650 CCA
BLOCK HEATER	1,800 WATTS, 15 AMP
BATTERY CHARGER	5 AMP
DIGITAL CONTROLLER	DSE 7310 MKII

MIMIC PANEL	DSE2510
REMOTE MONITORING	DSE2548
SOLAR BATTERY CHARGER	10 AMP

## NOTES:

- (1) Batteries are not included.
  - (2) For more warranty information, see operator's manual.
  - (3) The recommended oil is for normal applications.  
See operator's manual for more oil recommendations.
  - (4) Block heater is not included.
  - (5) 47 Gallon composite tank does not conform to UL2200.
  - (6) Run time is estimated.
- Specifications are subject to change without notice.



Sales: 507-357-6821  
Service: 507-357-6831

