



## Specification Sheet

# Commercial Mobile Generator

## Onan QG 5500 EFI



### Features and Benefits

- EFI provides improved hot and cold start capability
- Quietest and lowest vibration generator set in its class
- Integrated housing design
- Enclosed muffler for ease of installation
- Self-diagnostic capability to simplify troubleshooting
- Runs two ACs
- Digital regulation for voltage stability as loads change
- Electronic governor for voltage stability and frequency control
- 2-year limited warranty

### Weight, Size and Sound Level

<b>Weight</b>	290 lbs	(132 kg)
<b>Length</b>	33.6 in	(853 mm)
<b>Width</b>	22.2 in	(563 mm)
<b>Height</b>	16.7 in	(425 mm)
<b>Sound</b>	66 dB(A)	Readings at 10 ft (3 m), typical, half load

- Typical installation will further reduce sound level.

### Models and Ratings

Model	Fuel	Hz	Watts	Voltage	Amps	P.F	Phase	Circuit breaker
<b>5.8HGJAD-2138+</b>	Gasoline	60	5500	120	45.8	1.0	1	2 Pole, 30A
<b>5.8HGJAD-2558+#</b>	Gasoline	60	5500	120/240	22.9	1.0	1	2 Pole, 30A
<b>5.8HGJAD-2138+</b>	Gasoline	60	5500	120/240	22.9	1.0	1	2 Pole, 30A
<b>5.8HGJAD-2138+</b>	Gasoline	60	5500	120/240	22.9	1.0	1	2 Pole, 30A

- All 60 Hz models operate at 2400 r/min
- Ratings apply up to 3000 ft (914 m) altitude, 85° F (29.4° C).
- Temperature: Power output decreases 1% for every 10° F (5.5° C) increase
- Altitude: Power output decreases 3.5% for every 1000 ft (305 m) increase
- Ratings are at intermittent power output.

+ EFI generator sets require a chassis-specific fuel system kit. See F-0832E

# Splined shaft

◆ Evaporative spec: All model year 2011 and later spark-ignited small off-road engines rated at equal to or less than 19 Kilowatts, and equipment utilizing such engines must meet the evaporative emission requirements as specified in Title 13, California Code of Regulations, Chapter 15, Article 1, 40 CFR Part 1054 §1054.112, and 40 CFR Part 1060. EVAP capable units are required when the genset is the only engine attached to the fuel tank. For applications where the vehicle propulsion engine is connected to the EVAP system and the genset is not connected to the EVAP system, EVAP capable units are not required.

\*Ambient is defined as the air temperature measured at the cooling air inlet to the set

## Standard Features

- Electronic fuel Injection (EFI) for clean, smooth running under all conditions
- Electronic governor
- Cummins OHV engine
- Pressurized thru flow cooling system
- 4-point mounting system with coil spring vibration isolators
- Universal mounting tray with structural capability to support the generator set in commercial mobile applications
- Integral USDA Forest Service-approved spark-arrestor muffler
- Integral control box
- Instant one-touch stop switch
- Electronic ignition
- Self-diagnostic capability
- Hour meter
- Battery charging - 5 A
- Remote disable/continuous stop
- Start and run without AC output - engine run only
- Enclosed muffler provides noise reduction and ease of installation
- Sound-attenuated housing
- Waterproof remote connector
- Heavy-duty solenoid shift starter
- Electric fuel pump, long-life fuel filter
- Spin-on, full-flow oil filter
- Low oil pressure protection
- Over/under speed protection
- Low power factor field over current protection
- Digital voltage regulation
- Hydraulic pump standard on some models
- 10 ft generator set output leads

## Engine Details

**Model:** Cummins OHV EH65V gasoline engine

**Design:** 4-cycle, OHV, 90-degree V-twin

**Cylinders:** 2

**Bore:** 80 mm

**Stroke:** 65 mm

**Displacement:** 39.8 in<sup>3</sup> (653 cm<sup>3</sup>)

**Compression Ratio:** 8:1

**Oil Capacity:** 2.0 qt (1.9 L) including filter

**Power (max):** At 2400 r/min 11.6 hp

**Cooling:** Centrifugal blower, generator set mounted for high effectiveness, pressurized system, vertical flow

**Cooling Air Volume:** 60 Hz: 500 ft<sup>3</sup>/min (14.2 m<sup>3</sup>/min) at 2400 r/min. Air flow includes engine, generator set and control cooling air flow

### Fuel System:

Replaceable dry element air cleaner

Gasoline side-draft throttle body.

- Remote mount electronic fuel pump with positive fuel shutoff (45 psi), maximum fuel lift 3 ft (0.9 m)
- Combustion air volume: 60 Hz: 17.2 ft<sup>3</sup>/min (0.53 m<sup>3</sup>/min) at 2400 r/min

**Starting System:** Remote, 12 V, negative ground; automotive type starter with steel pinion and ring gear, automatic start disconnect, connector for remote start cable, start-stop rocker switch mounted on set control

**Ignition System:** Electronic magneto type with resistor plugs

**Lubrication:** Full pressure positive displacement lube oil pump, spin-on, full-flow lube oil filter, low oil pressure shutdown, dipstick

**Cylinder Crankcase:** Alloy aluminum with iron cylinder liners cast into the block, aluminum oil base

**Cylinder Head:** Aluminum, OHV, removable

## Average Fuel Consumption

Gasoline	No load	Half load	Full load
<b>5.5HGJAD</b>	0.35 Gal/h (1.3 L/h)	0.60 Gal/h (2.3 L/h)	0.95 Gal/h (3.6 L/h)

## Alternator Details

**Design:** Cummins revolving field, AC, 2-pole self-excited, two bearing

**Insulation System and Temperature Rise:** Meets requirements of NEMA MG-1, 1.65 & 1.66 and CSA C22.2, Std. 100 Motors and Generators

**Cooling:** Direct drive centrifugal blower, cast aluminum housing for excellent heat transfer

**Rotor:** Laminated electrical steel assembly press-fitted to shaft, balanced; heavy insulated copper wire windings; optimized air gap for improved waveform and motor starting; Class 200 magnet wire

**Stator:** Laminated electrical steel assembly, skewed for improved waveform; Class 200 quadrature wire with 70% more insulation over comparable generator sets

**Excitation:** Capped, digital voltage regulation

**DC Brushes:** Electrographic; long life

**Bearings:** Double-sealed pre-lubricated ball bearings

## Generator Set Performance

### Hydraulic pump:

- Fixed displacement gear pump, 1.5 Gal/min at 2500 psi
- A generator set with a hydraulic pump is rated with the pump idle
- When using a non-Cummins pump supplied by the customer, the hydraulic pump shaft seals must be capable of operating in a temperature environment of 225° F to 250° F. Seal failure will result in equipment damage

<b>Frequency regulation</b>	No load/Full load	1.7%	<b>Frequency regulation</b>	Constant load	1.7%
<b>Voltage regulation</b>	No load/Full load	2.0%	<b>Voltage regulation</b>	Constant load	1.7%

## Basic Dimensions

Dimensions in (mm)

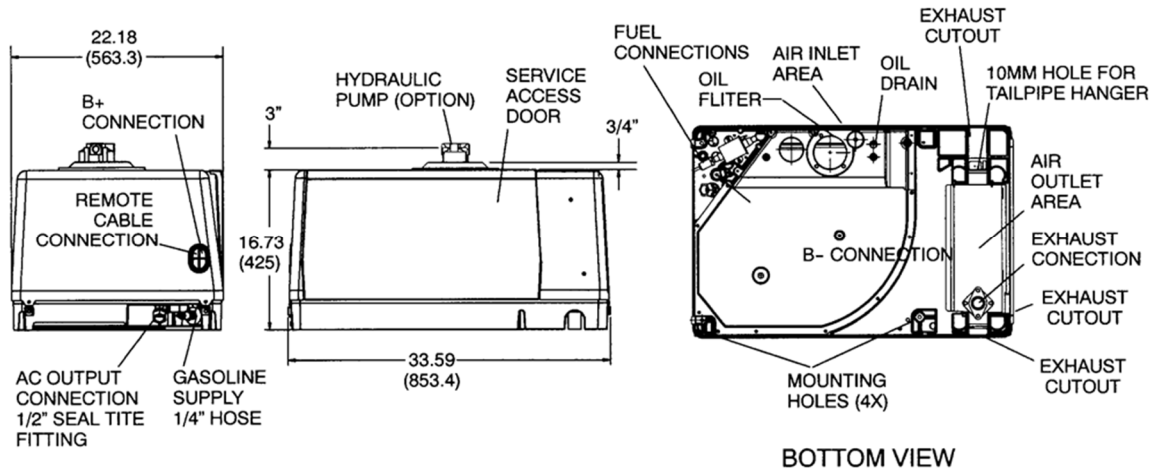

**Note:** This outline drawing is provided for general reference only and is not intended for design or installation. For more information see Operation and Installation manuals or obtain drawing 500-3449 and wiring diagram from your distributor/dealer.

## Accessories

- Remote control start/stop rocker switch (P/N 300-5331)
- Remote control with start/stop switch and hour meter (P/N 300-5332)
- Remote control with start/stop switch and DC voltmeter (P/N 300-5333)
- Remote control plug and wire harness 10 ft (P/N 338-3489-01), 30 ft (P/N 338-3489-02)
- Remote harness (P/N 300-4946) pigtail harness to connect to sealed remote connector
- Under floor mounting kit (P/N 405-6699)
- Installation template (P/N 539-2057)
- Tailpipe kit 22 in (P/N 155-3481-01), 26 in (P/N 155-3481-02)
- Exhaust tube, straight with flanged end 3 in (P/N 155-2610), 7 in (P/N 155-2424), 12.5 in (P/N 155-2610-01)
- Exhaust elbow, tight radius 90° to route exhaust through cutouts (P/N 155-3439)
- EFI generator sets require a chassis-specific fuel system kit. See F-0832E,

## Testing for RV Application

- Tested at extremes of temperature -20 °F (-29 °C) to 120 °F (49 °C) for starting and operation
- Tested installed
- Tested with commercial loads
- Tested in high humidity conditions
- Tested in salt spray conditions
- Tested in heavy airborne dust conditions
- Field test program
- 60 Hz models meet applicable U.S. EPA and California emissions standards.
- This generator set was designed and manufactured in facilities certified to ISO 9001
- CSA certified for CSA C22.2 std 100 and std 14



## Warranty Policy

The limited warranty covers any failures of the product resulting from a defect in material or factory workmanship under normal use and service for 2 years from warranty start date or 2,000 hours, whichever occurs first. Parts and labor will be covered for warrantable failures except routine maintenance during two years warranty coverage period.

## After Sale Support

### Largest Distributor/Dealer Support Network:

Cummins generator sets are supported by the largest and best trained worldwide authorized distributor/dealer network in the industry. This network of knowledgeable Cummins distributor/dealers will help you select and install the right generator set and accessories to meet the requirements of your specific application. This same network offers a complete selection of commonly used generator set maintenance parts, accessories and products plus manuals and specification sheets. They can answer your questions regarding proper operation, maintenance schedules and more.

**Manuals:** Operation and installation manuals ship with the generator set. To obtain additional copies or other manuals for this model, see your Cummins sales or service representatives and request the following manual numbers: Operator (A035D007), Installation (A035D003), Parts (983-0202), Service (A035D011).

To easily locate the nearest Cummins distributor/dealer in your area, or for more information, contact us at 1-800-CUMMINS, or [www.power.cummins.com](http://www.power.cummins.com)

<b>!</b>	<b>WARNING:</b>
Do not use this generator set on a boat. Such use may violate U.S. Coast Guard regulations, and can result in severe personal injury or death from fire, explosion, electrocution, or carbon monoxide poisoning.	

<b>!</b>	<b>WARNING:</b>
Back feed to a utility system can cause electrocution and/or property damage. Do not connect to any building electrical except through an approved device or after building main breaker is open.	

Contact your distributor/dealer for more information.



Cummins Inc.  
Box 3005  
Columbus, IN 47202-3005  
U.S.A  
1-800-CUMMINS™ (1-800-286-6467)  
[cummins.com](http://cummins.com)

©2020 Cummins Inc. All rights reserved.  
Specifications are subject to change without notice. A-1442 (04/20)