

W145PTOS W150PTOS W165PTOS

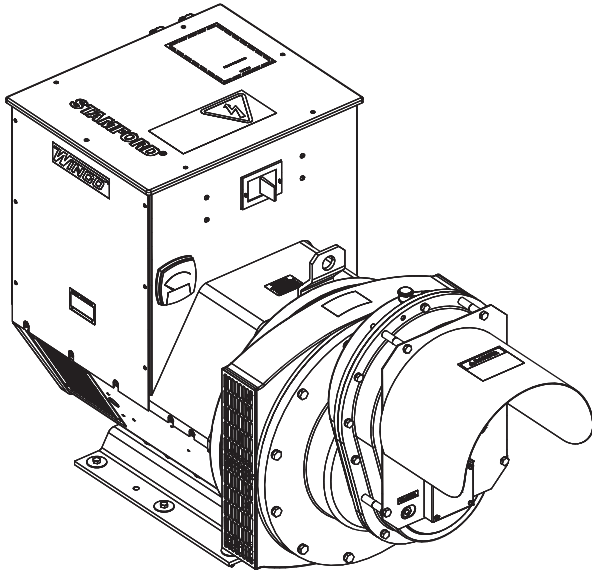

Designed, engineered, and manufactured in our facility located in Le Center, Minnesota, equipped with modern engineering, fabrication and assembly capabilities.

Rugged Design

Engineered and built tough with powder coat paint galvanealed steel.

Cast Iron Gearcase

Our own WINCO gearcases have proven their strength and durability for over 60 years and will keep doing so in the future.

Full Load Tested

Every generator is 100% load tested in-house.

STAMFORD

MODEL	VOLTAGE	STANDBY (125/40°C)			CONTINUOUS (105/40°C)		
		WATTS	AMPS 1.0 PF	AMPS 0.8 PF	WATTS	AMPS 1.0 PF	AMPS 0.8 PF
W150PTOS-3	120/240 1-PH	150,000	625	N/A	137,000	570	N/A
W145PTOS-4	120/208 3-PH	145,000	402	503	145,000	402	503
W145PTOS-17	120/240 3-PH	145,000	349	435	145,000	349	435
W165PTOS-18	277/480 3-PH	165,000	198	248	150,000	180	225
W165PTOS-21	346/600 3-PH	165,000	158	198	165,000	158	198

MOTOR STARTING (CODE G)

120/240 1-PH	75 HP
120/208 3-PH	70 HP
120/240 3-PH	70 HP
277/480 3-PH	70 HP
346/600 3-PH	70 HP

TOTAL HARMONIC DISTORTION < 5%

MAIN CIRCUIT BREAKER

120/240 1-PH	600A, 240V
120/208 3-PH	500A, 240V
120/240 3-PH	500A, 240V
277/480 3-PH	250A, 480V
346/600 3-PH	250A, 600V

BONDED NEUTRAL YES

120V RECEPTACLES⁽¹⁾ (1) NEMA 5-20 20A DUPLEX

240V RECEPTACLES⁽¹⁾ (1) NEMA 6-50 60A

FREQUENCY METER YES

GROUND LUG YES

FULL POWER PLUG INCLUDED

PTO INPUT SPEED 1000 RPM

INPUT SHAFT SIZE 1 3/4" 20-SPLINE

REQUIRED INPUT HP⁽²⁾

100PTOS-3	300
105PTOS-4	290
105PTOS-17	290
120PTOS-18	330
120PTOS-21	330

ASSEMBLED IN USA

UNIT WARRANTY⁽³⁾ 3 YEARS

GENERATOR END

GENERATOR END BRAND	STAMFORD
GENERATOR END MODEL	
SINGLE PHASE	UCI274C
THREE PHASE	UCI274D
WINDING	
240V 1-PH	06 - 4 LEAD
208/240/480V 3-PH	311 - 12 LEAD
600V 3-PH	17- 12 LEAD
VOLTAGE REGULATION	AVR +/-1%
AVR TYPE	AS440
TEMPERATURE RISE	
STANDBY	125/40°C
CONTINUOUS	105/40°C
BRUSHLESS	YES

SPEED	1800 RPM
STATOR	2/3 PITCH
WINDINGS	100% COPPER
STATOR WINDING	
SINGLE PHASE	SINGLE LAYER CONCENTRIC
THREE PHASE	DOUBLE LAYER CONCENTRIC
BEARINGS	SINGLE (MAINTENANCE FREE)
EFFICIENCY PEAK	
W145PTOS	84.9%
W150PTOS & W165PTOS	91.1%
INSULATION	CLASS H
INGRESS PROTECTION	IP23

GEARCASE OIL

OIL TYPE	SAE 85W-90-140
OIL CAPACITY	2.75 PINT

SHIPPING

SHIPPING DIMENSIONS (L x W x H)	55" x 29" x 36"
SHIP WEIGHT	
W145PTOS	1,482 LBS
W150PTOS	1,488 LBS
W165PTOS	1,516 LBS
FREIGHT CLASS	65

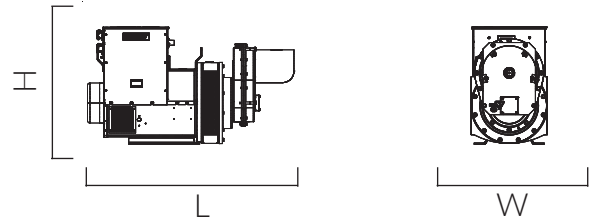

OPTIONAL ACCESSORIES

PTO SHAFT	1 3/4" 20-SPLINE
	1 3/4" 21 SPLINE

PTO TRAILER	TDM91
MANUAL TRANSFER SWITCH	VARIES

INSTALLATION DIMENSIONS

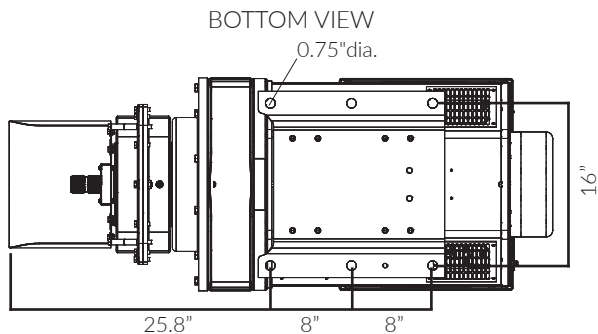

RECEPTACLE PANEL (1)

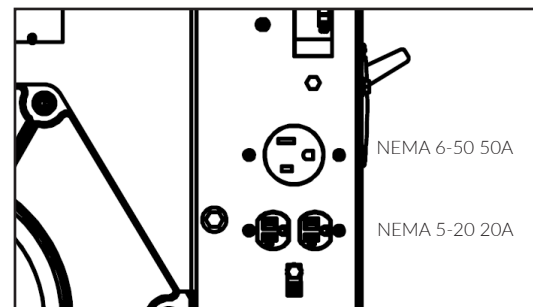

- NOTES:
- (1) 480V & 600V are hard wired only.
 - (2) Required HP at PTO of tractor for full rated power. Each 2 HP equals approximately 1kW of electric power.
 - (3) For more warranty information, see operator's manual.

Specifications are subject to change without notice.



Sales: 507-357-6821
Service: 507-357-6831

