



INSTALLATION MANUAL

SERVICE ENTRY WHOLE HOUSE AUTOMATIC TRANSFER SWITCH (ATS)

All fleX Controller® Models



ACTIVATE YOUR WARRANTY

by registering your product:
championpowerequipment.com

SERIAL NO.



or visit championpowerequipment.com

READ AND SAVE THIS MANUAL. This manual contains important safety precautions which should be read and understood before operating the product. Failure to do so could result in serious injury. This manual should remain with the product.
Specifications, descriptions and illustrations in this manual are as accurate as known at the time of publication, but are subject to change without notice.

TABLE OF CONTENTS

Introduction	3
Safety Definitions	3
Important Safety Instructions	4
Instructions for Champion Automatic Transfer Switch with fleX Controller® Module	4
Before Installation	4
Safety Labels	5
Safety Symbols	7
Controls and Features	8
Champion Automatic Transfer Switch with fleX Controller® Module - Model 201020 (100A)	8
Champion Automatic Transfer Switch with fleX Controller® Module - Models 201039 (200A) / 201355 (150A)	9
Safety and Dataplate Labels	10
Manual Switch Operation	11
Unpacking	12
Location and Mounting	12
Electrical Grommet(s)	12
Installation Wiring for ATS Utility Socket	12

Installation	13
Wiring the ATS	13
Battery Charger Wiring	14
Utility Sensing Fuse Block	14
Low Voltage Control Relays	14
Settings on the fleX Controller®	15
LEDs	16
Buttons	16
400A Installation	16
Primary ATS LEDs	19
Secondary ATS LEDs	19
Wi-Fi Setup Method	20
ATS and HSB Status Using WIFI	22
Connecting the Load Management Systems	22
Bond Mode (System Learning Mode)	22
Confirming Bond Mode	26
Load Teaching System	27
Full System Check	27
Specifications	29
Technical Specifications	29
Short-circuit withstand and closing ratings	29
Wire - Lug Rating - Torque	29
201020 ATS Wiring Diagram	30
201039 ATS Wiring Diagram	31
201355 ATS Wiring Diagram	32
Warranty	33

 FOR PARTS BREAKDOWN

Search by model number at
championpowerequipment.com

INTRODUCTION

Congratulations on your purchase of a Champion Power Equipment (CPE) product. CPE designs, builds, and supports all of our products to strict specifications and guidelines. With proper product knowledge, safe use, and regular maintenance, this product should bring years of satisfying service.

Every effort has been made to ensure the accuracy and completeness of the information in this manual at the time of publication, and we reserve the right to change, alter and/or improve the product and this document at any time without prior notice.

CPE highly values how our products are designed, manufactured, operated, and serviced as well as providing safety to the operator and those around the generator. Therefore, it is IMPORTANT to review this product manual and other product materials thoroughly and be fully aware and knowledgeable of the assembly, operation, dangers and maintenance of the product before use. Fully familiarize yourself, and make sure others who plan on operating the product fully familiarize themselves too, with the proper safety and operation procedures before each use. Please always exercise common sense and always err on the side of caution when operating the product to ensure no accident, property damage, or injury occurs. We want you to continue to use and be satisfied with your CPE product for years to come.

When contacting CPE about parts and/or service, you will need to supply the complete model and serial numbers of your product. Transcribe the information found on your product's nameplate label to the table below.

CPE TECHNICAL SUPPORT TEAM
1-877-338-0999
MODEL NUMBER
201020, 201355, 201039
SERIAL NUMBER
DATE OF PURCHASE
PURCHASE LOCATION

SAFETY DEFINITIONS

The purpose of safety symbols is to attract your attention to possible dangers. The safety symbols, and their explanations, deserve your careful attention and understanding. The safety warnings do not by themselves eliminate any danger. The instructions or warnings they give are not substitutes for proper accident prevention measures.

DANGER

DANGER indicates a hazardous situation which, if not avoided, will result in death or serious injury.

WARNING

WARNING indicates a hazardous situation which, if not avoided, could result in death or serious injury.

CAUTION

CAUTION indicates a hazardous situation which, if not avoided, could result in minor or moderate injury.

NOTICE

NOTICE indicates information considered important, but not hazard-related (e.g., messages relating to property damage).

IMPORTANT SAFETY INSTRUCTIONS

WARNING

Cancer and Reproductive Harm - www.P65Warnings.ca.gov

Instructions for Champion Automatic Transfer Switch with flex Controller® Module

THE CHAMPION AUTOMATIC TRANSFER SWITCH WITH flex Controller® MODULE IS NOT FOR “DO-IT-YOURSELF” INSTALLATION. It must be installed by a qualified electrician thoroughly familiar with all applicable electrical and building codes.

This manual has been prepared for familiarizing servicing dealer/installer with the design, application, installation and servicing of the equipment.

Read the manual carefully and comply with all instructions.

This manual or a copy of this manual should remain with the switch. Every effort has been taken to make sure that the contents of this manual are accurate and current.

The manufacturer reserves the right to change, alter or otherwise improve this literature and the product at any time without prior notice and without any obligation or liability whatsoever.

The manufacturer cannot anticipate every possible circumstance that might involve a hazard.

The warnings in this manual, tags and decals affixed to the unit are, therefore, not all-inclusive. If using a procedure, work method or operating technique the manufacturer does not specifically recommend follow all codes to ensure safety for personnel.

Many accidents are caused by failing to follow simple and fundamental rules, codes and precautions. Before installing, operating or servicing this equipment, read the SAFETY RULES carefully.

The publications that cover the safe use of ATS and installation are the following NFPA 70, NFPA 70E, UL 1008 and UL 67. It is important to refer to the latest version of any standard/code to ensure correct and current information. All installations must comply with local municipal, state and national codes.

Before Installation

WARNING

Per OSHA 3120 Publication; “lockout/tagout” refers to specific practices and procedures to safeguard individuals from the unexpected energization or startup of machinery and equipment, or the release of hazardous energy during installation, service or maintenance activities.

DANGER

Be certain that the power from the utility is turned off and all backup sources are locked out before starting this procedure. Failure to do so could result in serious injury or death. Be aware, automatic start generators will start upon loss of utility mains power unless locked in the “off” position.

Check and confirm that the flex Controller® is in the “OFF” position. It is recommended to pull the control module fuse located on the front panel and turn the circuit breaker to the OFF position.

This generator has ON/OFF switches that when turned off, will shut down the HSB (if running) and deactivate the flex Controller® preventing future starts. These switches should be used in instances where the HSB needs to stay off regardless of utility power presence. When either switch is in the OFF position, the HSB will not exercise or start for any reason.





CAUTION



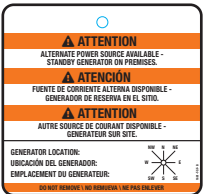
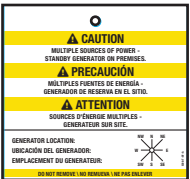

Consult with your Local municipal, State and National electrical codes for proper mandatory wiring methods.

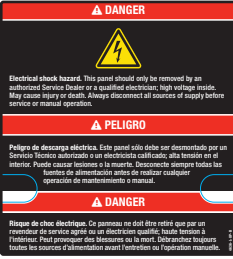
Safety Labels

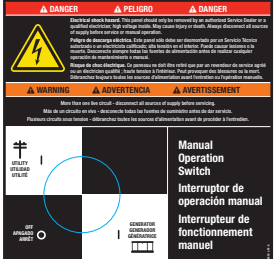
These labels warn you of potential hazards that can cause serious injury. Read them carefully.

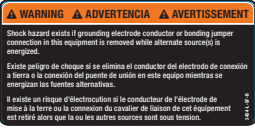
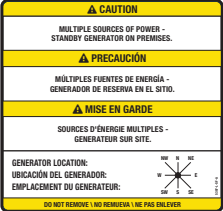

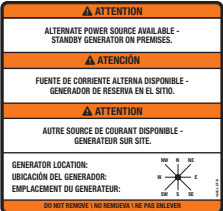
If a label comes off or becomes hard to read, contact Technical Support Team for possible replacement.

	HANGTAG/LABEL	DESCRIPTION	PART NUMBER
1		Alternate Power Source	1681-T-SF (1 per unit) Loose in IM bag.
2		Multiple Sources of Power	5398-T-SF (1 per unit) Loose in IM bag.
3		Caution. Overcurrent device.	1943-L-PR
4		Danger. Electrocutation shock hazard.	4640-L-SF
5		Danger. Electrocutation shock hazard.	4636-L-OP
6		Danger. Electrocutation shock hazard.	4656-L-SF
7		Danger. Electrocutation shock hazard.	4635-L-SF

	HANGTAG/LABEL	DESCRIPTION	PART NUMBER
8	 <p>WARNING ADVERTENCIA AVERTISSEMENT</p> <p>Check hazard exists if grounding electrode conductor or bonding jumper connection in this equipment is removed while alternate source(s) is energized.</p> <p>Cuando peligro de choque si se elimina el conductor del electrodo de conexión a tierra o la conexión del puente de unión en este equipo mientras se energizan las fuentes alternativas.</p> <p>Il existe un risque d'électrocution si le conducteur de l'électrode de mise à la terre ou la connexion du cavalier de liaison de cet équipement est retiré alors que la ou les autres sources sont sous tension.</p>	ATS Ground Hazard	3454-L-SF (1 per unit) Loose in IM bag.
9	 <p>CAUTION</p> <p>MULTIPLE SOURCES OF POWER - STANDBY GENERATOR ON PREMISES.</p> <p>PRECAUCIÓN</p> <p>MÚLTIPLES FUENTES DE ENERGÍA - GENERADOR DE RESERVA EN EL SITIO.</p> <p>MISE EN GARDE</p> <p>SOURCES D'ÉNERGIE MULTIPLES - GENERATEUR SUR SITE.</p> <p>GENERATOR LOCATION: UBICACIÓN DEL GENERADOR: EMPLACEMENT DU GENERATEUR:</p>  <p>DO NOT REMOVE / NO REMOVER / NE PAS OLEVER</p>	Multiple Sources of Power	5397-L-SF (2 per unit) Loose in IM bag.
10	 <p>ATTENTION</p> <p>ALTERNATE POWER SOURCE AVAILABLE - STANDBY GENERATOR ON PREMISES.</p> <p>ATENCIÓN</p> <p>FUENTE DE CORRIENTE ALTERNA DISPONIBLE - GENERADOR DE RESERVA EN EL SITIO.</p> <p>ATTENTION</p> <p>AUTRE SOURCE DE COURANT DISPONIBLE - GENERATEUR SUR SITE.</p> <p>GENERATOR LOCATION: UBICACIÓN DEL GENERADOR: EMPLACEMENT DU GENERATEUR:</p>  <p>DO NOT REMOVE / NO REMOVER / NE PAS OLEVER</p>	Alternate Power Source	4642-L-SF (2 per unit) Loose in IM bag.

Safety Symbols

Some of the following symbols may be used on this product. Please study them and learn their meaning. Proper interpretation of these symbols will allow you to more safely operate the product.

SYMBOL	MEANING
	Read Installation Manual. To reduce the risk of injury, user must read and understand installation manual before using this product.
	Ground. Consult with local electrician to determine grounding requirements before operation.
	Electric Shock. Improper connections can create an electrocution hazard.

CONTROLS AND FEATURES

Read this installation manual before installing your transfer switch. Familiarize yourself with the location and function of the controls and features. Save this manual for future reference.

Champion Automatic Transfer Switch with flex Controller® Module - Model 201020 (100A)

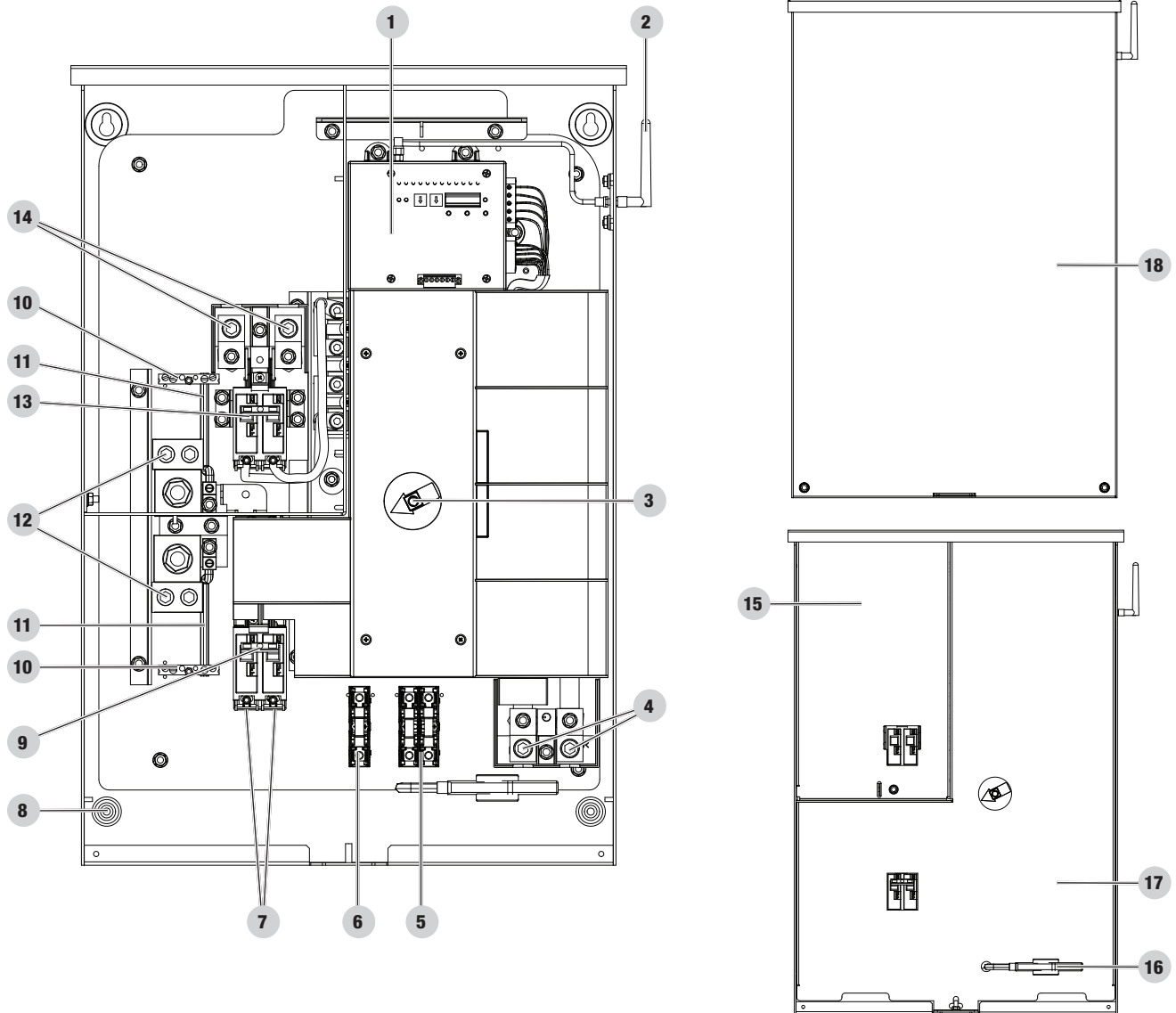

- | | |
|---|--|
| 1. flex Controller® | 11. Ground Bond Wire |
| 2. Antenna | 12. Neutral Bar |
| 3. Manual Operation Switch | 13. Utility Circuit Breaker/ Utility Service Disconnect |
| 4. Load L1 and L2 Terminals (L1/L2) - under plastic cover | 14. Utility Supply L1 and L2 Terminals (U-L1/U-L2) - under plastic cover |
| 5. Two Wire Sensing Fuse Block | 15. Dead Front – Utility Lockout |
| 6. Battery Charger Fuse Block | 16. Manual Operation Switch Handle |
| 7. Generator Supply L1 and L2 Terminals (G-L1/G-L2) | 17. Dead Front |
| 8. Mounting Holes - 1 in each corner (4 Total) | 18. Front Cover |
| 9. Generator Circuit Breaker- 100A | |
| 10. Ground Bar | |

**Champion Automatic Transfer Switch with fleX Controller® Module -
Models 201039 (200A) / 201355 (150A)**

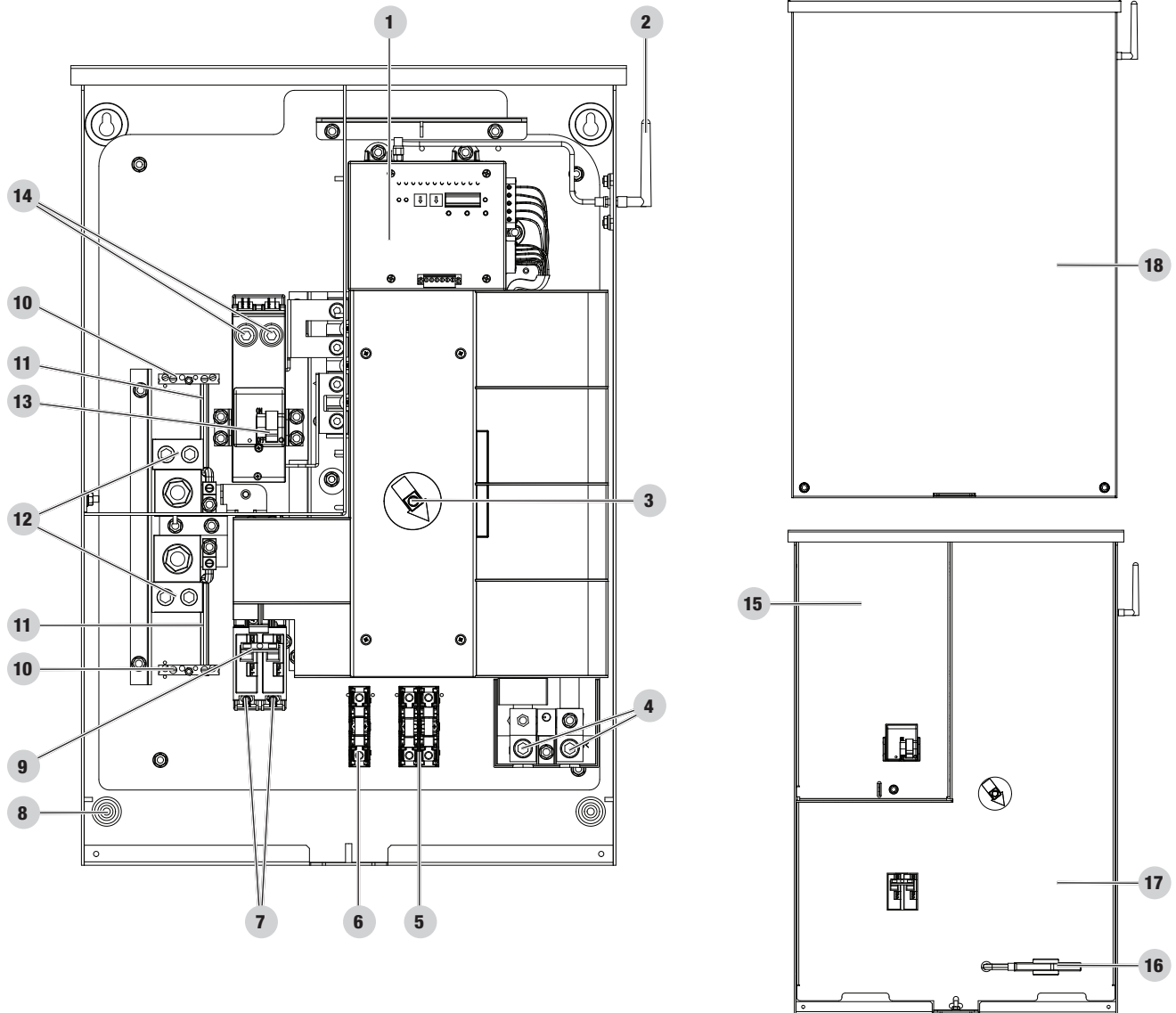

- | | |
|---|---|
| 1. fleX Controller® | 11. Ground Bond Wire |
| 2. Antenna | 12. Neutral Bar |
| 3. Manual Operation Switch | 13. Utility Circuit Breaker/ Utility Service Disconnect |
| 4. Load L1 and L2 Terminals (L1/L2) - under plastic cover | 14. Utility Supply L1 and L2 Terminals (U-L1/U-L2) |
| 5. Two Wire Sensing Fuse Block | 15. Dead Front – Utility Lockout |
| 6. Battery Charger Fuse Block | 16. Manual Operation Switch Handle and Storage |
| 7. Generator Supply L1 and L2 Terminals (G-L1/G-L2) | 17. Dead Front |
| 8. Mounting Holes - 1 in each corner (4 Total) | 18. Front Cover |
| 9. Generator Circuit Breaker- 201039 (100A) / 201355 (100A) | |
| 10. Ground Bar | |

Safety and Dataplate Labels

These labels warn you of potential hazards that can cause serious injury. Read them carefully.

If a label comes off or becomes hard to read, contact Technical Support Team for possible replacement.

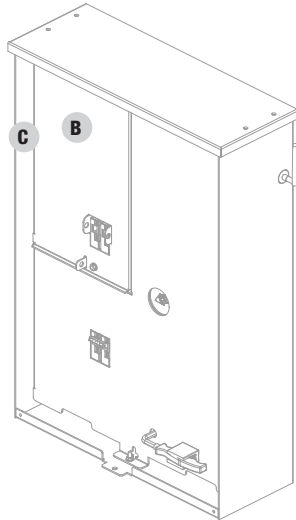

Back

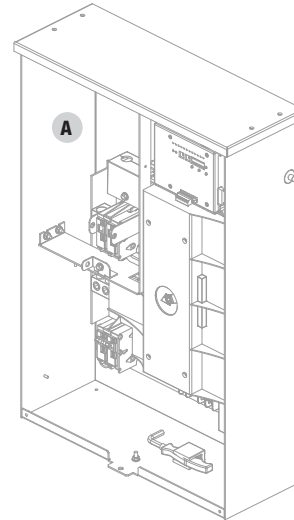

Inside

	LABEL	DESCRIPTION
A		FCC
B		WiFi SSID and password
C		201039 Dataplate
		201355 Dataplate
		201020 Dataplate

MANUAL SWITCH OPERATION

flex Automatic Transfer Switch (ATS) has the ability to switch manually between generator or utility as required. The ATS has a storage position (16) for a manual operation switch handle that allows the transfer between generator, OFF, and utility. In the event of manual transfer need, adjust the transfer switch manually by removing the manual operation switch handle (16) and inserting into the keyed center of the switch to rotate.

1. Remove Manual Operation Switch Handle, and insert the handle into the center switch key way.
2. Move to either Generator, Off, or Utility.

Generator - move the switch down, once an audible click is heard, move fully so the red arrow points fully in the generator zone.

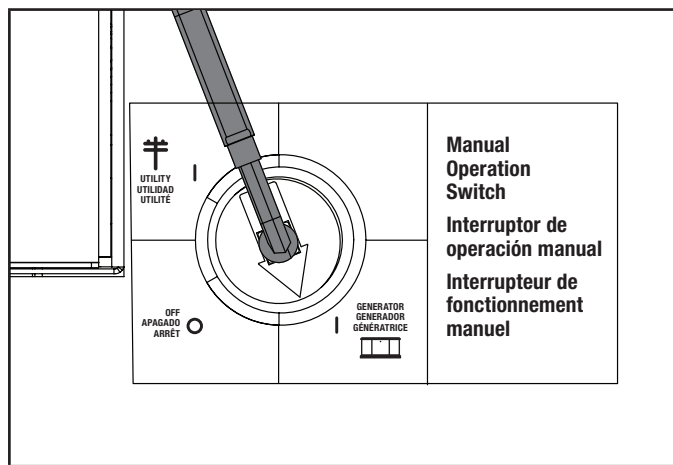

Off - move through the switch position into Off, until an audible click is heard, move so the red arrow points fully in the OFF zone.

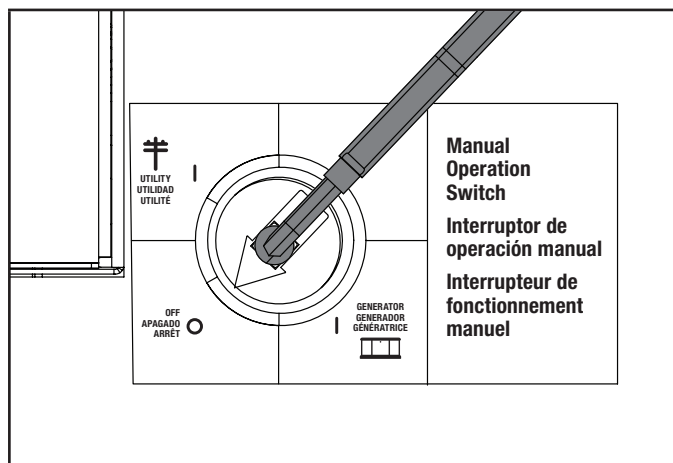

Utility - move the switch up, once the audible click is heard, move fully so the arrow points fully in the utility zone.

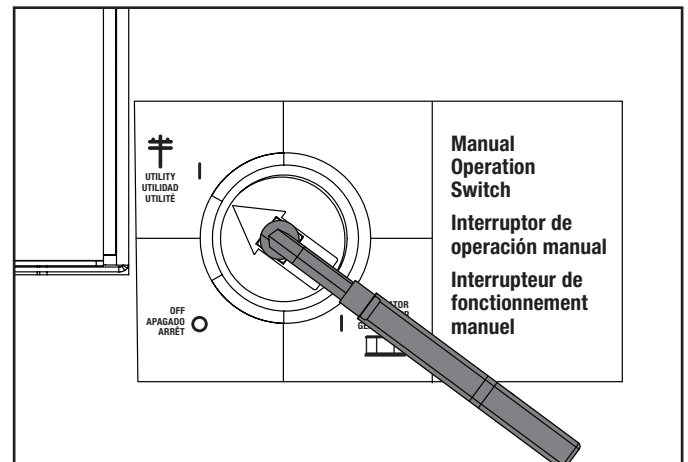

UNPACKING

1. Use care when unpacking to avoid damaging transfer switch components.
2. Allow the ATS to acclimate to room temperature for a minimum of 24 hours before unpacking to prevent condensation on the electrical apparatus.
3. Use a wet/dry vacuum cleaner or a dry cloth to remove dirt and packing material that may have accumulated in the transfer switch or any of its components during storage.
4. Do not use compressed air to clean the switch, cleaning with compressed air can cause debris to lodge in the components and damage the switch per the ATS manufacturers specifications.
5. Retain the ATS manual with or near the ATS for future reference.

TOOLS REQUIRED	NOT INCLUDED
5/16 in. Hex Wrench	Mounting Hardware
	Line Voltage Wire
1/4 in. Flat Screwdriver	Conduit
	Fittings

Location and Mounting

Install the ATS as close as possible to utility meter socket. Wires will run between the ATS and main distribution panel, proper installation and conduit are required by code. Mount the ATS vertically to a rigid supporting structure. To prevent the ATS or enclosure box from distortion, level all mounting points; use washers behind the mounting holes (outside the enclosure, between enclosure and supporting structure), see following image. The recommended fasteners are 1/4" lag screws. Always follow local code.

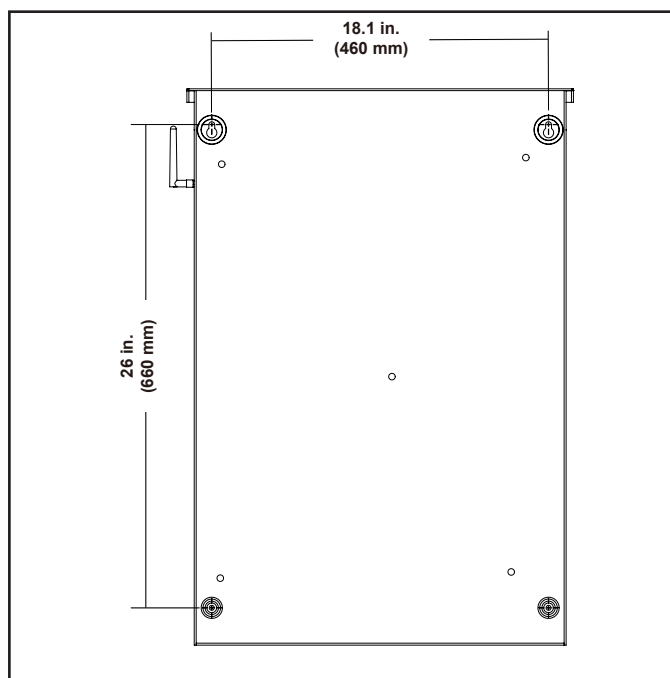

Electrical Grommet(s)

Grommets can be used in any enclosure knockout for NEMA 1 installations. Grommets can only be used in the bottom enclosure knockouts for NEMA 3R installations, when installed outside.

Installation Wiring for ATS Utility Socket

⚠ WARNING

The manufacturer recommends that a licensed electrician or an individual with complete knowledge of electricity perform these procedures.

Always be certain that the power from the main panel is turned "OFF" and all backup sources are locked out prior to removal of the cover or removal of any wiring of the utility main electrical distribution panel.

Be aware, automatic start generators will start upon loss of utility main power unless locked in the "OFF" position.

Failure to do so could result in serious injury or death.

⚠ CAUTION

Consult with your Local municipal, State and National electrical codes for proper mandatory wiring methods.

Conductor sizes must be adequate to handle the maximum current to which they will be subjected. The installation must comply fully with all applicable codes, standards and regulations. Conductors must be properly supported, of approved insulation materials, protected by approved conduit and with the correct wire gauge size in accordance with all applicable codes. Before connecting wire cables to terminals, remove any surface oxides from the cable ends with a wire brush. All power cables must enter the enclosure through the enclosure knockouts.

1. Determine where the flexible, liquid tight conduit will pass through the building from the inside to outside. When you are certain that there is adequate clearance on each side of the wall, drill a small pilot hole through the wall to mark the location. Drill an appropriate sized hole through the sheathing and siding.
2. In compliance with all local electrical codes, route the conduit along ceiling/floor joists and wall studs to the location where the conduit will pass through the wall to the exterior of the house. Once the conduit is pulled through the wall and in proper position to attach to the HSB generator, place silicone caulk around the conduit on both side of the hole, inside and outside.
3. Mount the ATS near the Utility meter socket.

INSTALLATION

Wiring the ATS

NOTICE

The flex ATS controls the automatic startup and shutdown of the flex HSB using Power Line Communication (PLC). The PLC system utilizes the L1 and L2 power wires that run between the ATS and HSB for communication. As a result, there are no wires that need to be run between the ATS and HSB besides the power wires (L1, L2, N, G) and battery charger wires.

1. Have authorized utility personnel pull the utility meter from the meter socket.

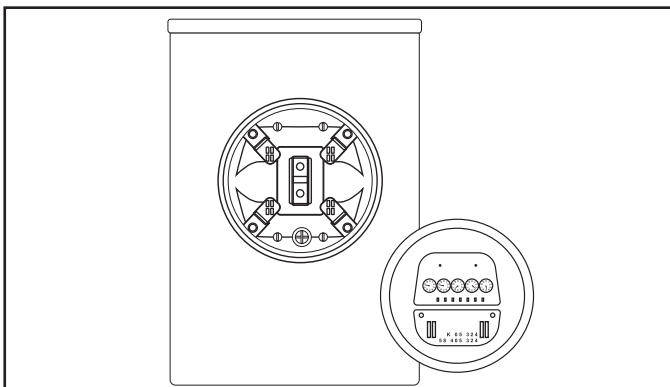

2. Remove front cover and dead front of ATS.
3. Connect Utility (U-L1 / U-L2) to ATS Utility supply terminals (14). Torque to 275 in-lbs.
4. Connect Utility N to Neutral lug (12). Torque to 275 in-lbs.
5. Connect earth GROUND to GROUND bar (10). Torque to 35-45 in-lbs. NOTE: GROUND and NEUTRAL bonded in this panel.

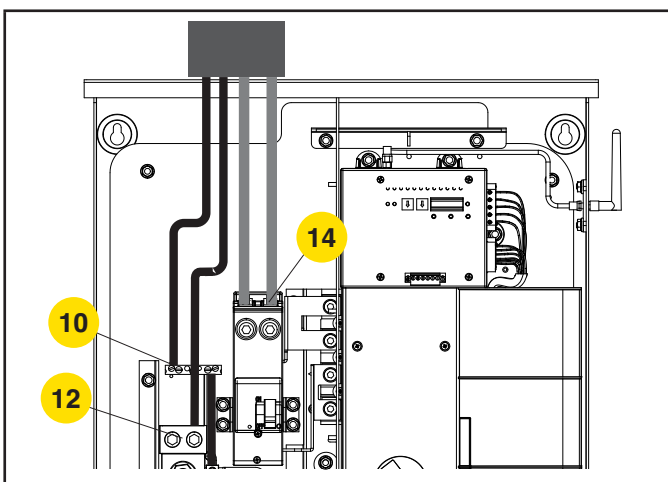

6. Connect Generator G-L1 / G-L2 to Generator supplier terminals (7). Torque to 45-50 in-lbs.
7. Connect Generator Neutral to neutral bar (12). Torque to 275 in-lbs.
8. Connect Generator GROUND to GROUND bar (10). Torque to 35-45 in-lbs. NOTE: GROUND and NEUTRAL bonded in this panel.

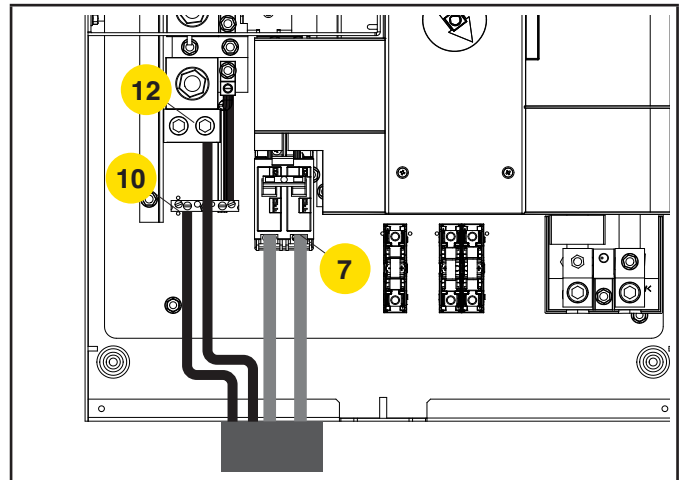

9. Connect Load bars L1 and L2 to distribution panel (4). Torque to 275 in-lbs.
10. Pull NEUTRAL from ATS to distribution panel (12). Torque to 275 in-lbs.
11. Pull GROUND (⊥) from ATS to distribution panel (10). Torque to 35-45 in-lbs.

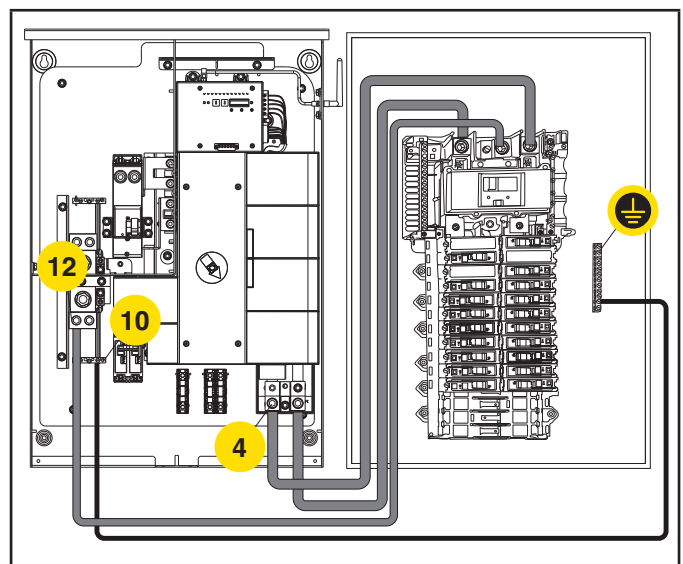

CAUTION

Remove bond from distribution panel if installed.

Battery Charger Wiring

The fleX Controller® HSB contains a 24V battery charger that is powered by 120V AC. The battery charger receives 120V AC power from the fleX Controller® ATS using the single fuse block located in center of the ATS.

1. Run two wires from the ATS to the HSB for the battery charger circuit.

The battery charger circuit is 120V AC, 10 amp maximum. Wires need to be sized accordingly.

Wiring can run in the same conduit as the L1, L2, Neutral and Ground wires from the previous section provided:

- 1a. Battery charger wire has an insulation rating equal to or greater than 264VAC.
- 1b. Battery charger wire is suitable for outdoor installation.
- 1c. Allowed by local code and meets NFPA 70.
2. ATS Connections for battery charger.
 - 2a. L1 - Bottom terminal of the fuse block in the ATS (6).
 - 2b. Neutral - Neutral block (12).

See picture below for location of fuse block and neutral block.

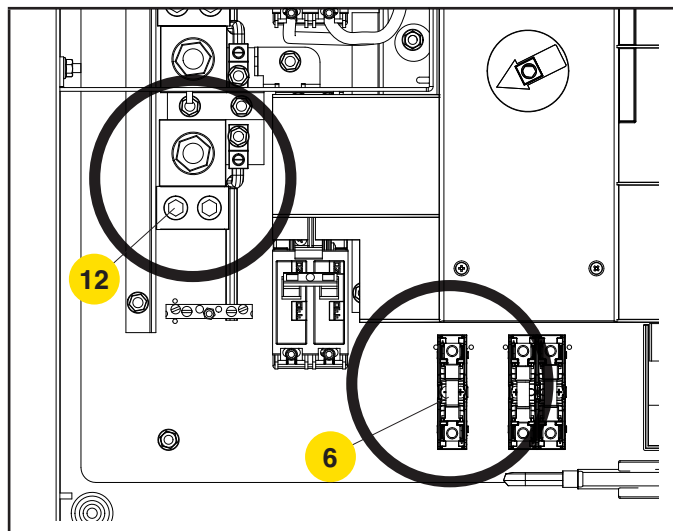

3. HSB Connection for battery terminals

3a. The terminal block is prewired by the factory to the charger L and N. A 120 VAC circuit must be installed for battery charging from the ATS or another 120VAC circuit. Refer to fleX Controller® HSB installation manual for more information.

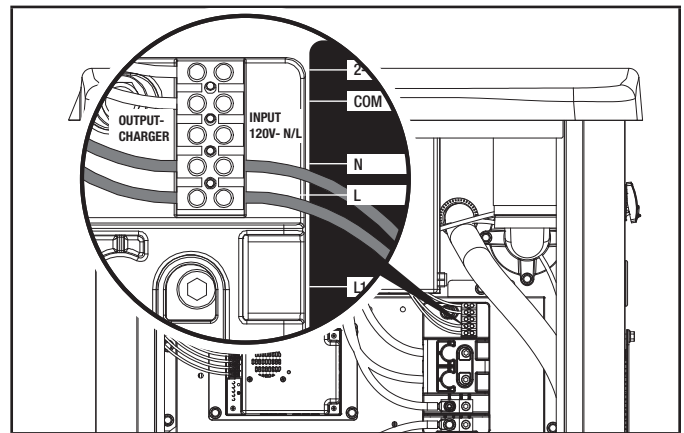

Utility Sensing Fuse Block

The utility sensing fuse block is not used in a typical installation. The fuse block is only used when connecting the Champion fleX ATS to a non-Champion HSB that monitors utility voltage to control automatic generator start/stop. The potential voltage between the two fuses is 240V AC.

Do not use the utility sensing block for the battery charging circuit. The battery charging fuse block is located next to the utility sensing fuse block.

Low Voltage Control Relays

The fleX Controller® ATS has two low voltage relays that can be used to manage the load of air conditioners or other devices that utilize low voltage controls. The ATS's two low voltage relays are called AC1 and AC2 and are found on the fleX Controller® as shown in the picture below.

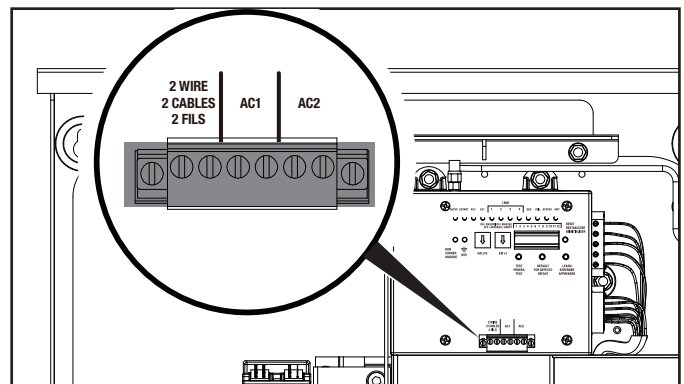

CONNECTING TO AC1 AND AC2

For air conditioner or other low voltage controls, route your low voltage wiring into the ATS using code appropriate conduit and fittings. Connect the wiring to pin 1 and pin 2 of either AC1 or AC2 as shown in the previous diagram.

Settings on the flex Controller®

1. On the ATS flex Controller®, set the two circular pots that are located to the left of the DIP switches to match the rated power output of the generator for your fuel type.

1st pot (left pot) is 10's value, 2nd pot (right pot) is 1's value, do not go over generator rating. If wattage rating of generator falls between settings choose the next lower value; e.g. generator rating is 22,000W, set pots to 2 and 2 or if wattage is not even 1000, set to the smaller value, e.g 12,500W, set pots to 1 and 2.

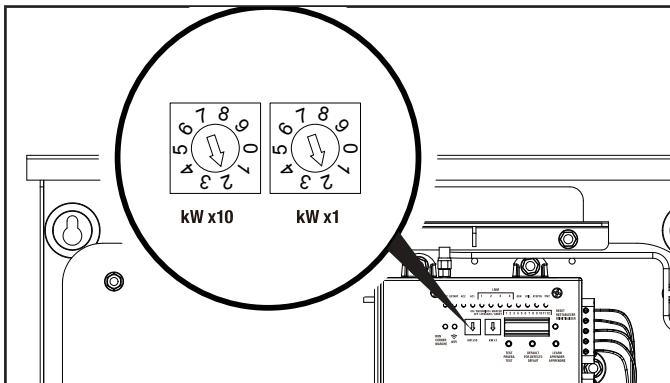

NOTICE

All DIP switches are set to ON by default from the factory except for switch #9 which is set to OFF.

2. Verify the DIP switches are set for your installation. Adjust as needed.

DIP SWITCH SETTINGS

Switch 1. Load Module 1 Lockout

- **On**= Load Module 1 is being managed. Load Module 1 is the lowest priority of the 4 load modules. This load will be turned off first as the ATS manages the home's load.
- **Off**= Load module 1 will stay off during HSB power.

Switch 2. Load Module 2 Lockout

- **On**= Load Module 2 is being managed.
- **Off**= Load module 2 will stay off during HSB power.

Switch 3. Load Module 3 Lockout

- **On**= Load Module 3 is being managed.
- **Off**= Load module 3 will stay off during HSB power.

Switch 4. Load Module 4 Lockout

- **On**= Load Module 4 is being managed. Load Module 4 is the highest priority of the 4 load modules. This load will be turned off last as the ATS manages the homes load.
- **Off**= Load module 4 will stay off during HSB power.

Switch 5. Frequency Protection.

- **On**= All managed loads will be turned off when if the HSB frequency drops below 58 Hz.
- **Off**= All managed loads will be turned off when if the HSB frequency drops below 57 Hz.

Switch 6. Secondary ATS Bond Mode

- **On**= Bond mode ON
- **Off**= Bond mode OFF

Switch 7. Power Management

- **On**= ATS is managing the home's load.
- **Off**= ATS has disabled power management.

Switch 8. PLC vs. Two Wire Communication

- **On**= ATS will control HSB startup and shutdown through PLC. This is the preferred method of communication however it requires the HSB to be an flex controlled HSB.
- **Off**= ATS will control the start of the HSB using the 2 Wire Relay.

Switch 9. Test HSB with Load

- **On**= Test occurs with load.
- **Off**= Test occurs without load.

Switch 10. Primary/Secondary

- **On**= This ATS is the primary or only ATS. <- most common.
- **Off**= This ATS is being controlled by a different flex Controller® ATS. Used for installations that require two ATS boxes (i.e. 400A installations). When off, low voltage AC1/AC2 or LMM connections can be made from either primary or secondary ATS. Low voltage AC1/AC2 or LMM connections can be made from either primary or secondary ATS. All secondary ATS AC1/AC2 or LMM connections are controlled by the primary ATS during generator operation. Primary ATS DIP switch 6 must be ON.

Switch 11. Exercise Test

- **On**= Exercise tests will occur per the schedule that is programmed into the flex Controller®.
- **Off**= Exercise tests are disabled.

Switch 12. Time delay for HSB to accept load.

- **On**= 45 seconds.
 - **Off**= 7 seconds.
3. Have authorized utility personnel reconnect the utility meter to the meter socket.
 4. Verify voltage at utility circuit breaker.
 5. Turn on utility circuit breaker.
 6. ATS flex Controller® module will begin boot up process. Allow ATS flex Controller® module to fully boot up (approximately 6 minutes).

7. Home should be fully powered at this point.

LEDs

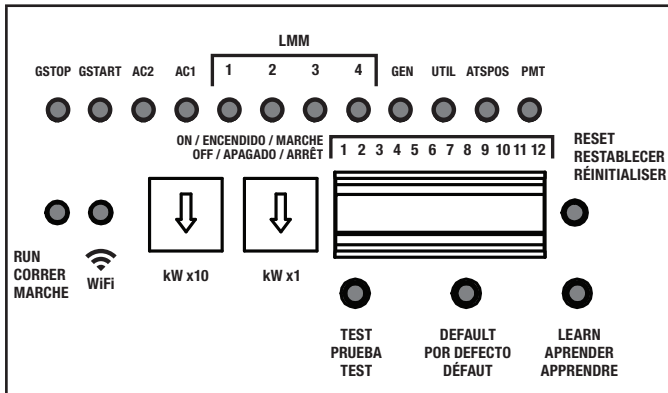

LED	Function	Off	Red	Green
GSTOP	Generator is stopped	Did not stop	Reset	Off
GSTART	Generator is running	Off	Test mode	Running
AC1	Air conditioner 1	Off	Generator	Utility
AC2	Air conditioner 2	Off	Generator	Utility
LMM1	Load Management Module 1	Off	Generator	Utility
LMM2	Load Management Module 2	Off	Generator	Utility
LMM3	Load Management Module 3	Off	Generator	Utility
LMM4	Load Management Module 4	Off	Generator	Utility
GEN	Generator condition	Off	Fault	Normal
UTIL	Utility	Off	Fault	Normal
ATSP0S	ATS position	Off	Generator	Utility
PMT	Power management	Off	Generator	Utility
RUN	flex Controller is powered	Off	Fault	Normal
Wi-Fi	Wireless Connectivity	Off	Not connected	Connected

Buttons

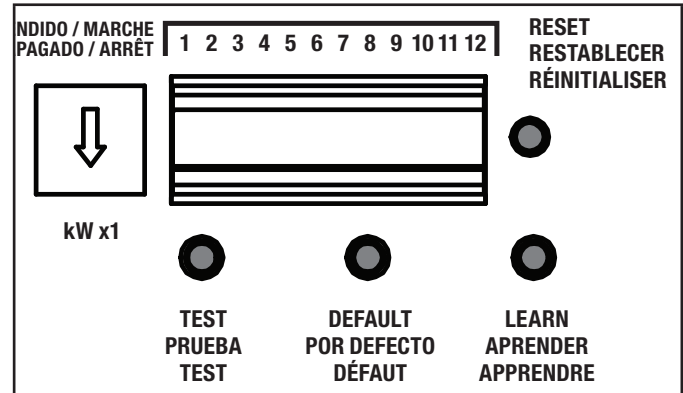

TEST – Simulates a power outage by ignoring the utility signal. The generator starts, and the ATS transfers house loads to the generator; DIP 9 must be ON for transfer. This is a 15-minute test cycle. At the end of the test cycle, if utility power is available, the cycle ends, the ATS transfers back to the utility, and the generator continues running for a 60-second cool down. If the cycle needs to be canceled, the TEST button can be pressed again to cancel. In this case, the ATS transfers back to the utility, and the generator runs a 60-second cool down. See the HSB Installation Manual, “HSB Tests Under Load” section, for the proper procedure.

DEFAULT – Resets all stored variables to factory specifications. The button must be held for at least 14 seconds. **NOTE: The BOND and LEARN process must be performed again, as in the initial setup.**

LEARN – Runs the BOND MODE process for system setup. BOND MODE allows the flex Controller to identify all system components—HSB, ATS, and/or LMM. The ATS must bond to all devices connected to the system to establish communication links required for normal operation, including the HSB and any LMMs, if available or applicable. See the “BOND MODE” steps in this manual for the proper procedure.

RESET – Initiates a shutdown of the ATS flex Controller and performs a hard reset; the action is immediate. This button is recessed to prevent accidental contact. Use a small, pointed object to actuate. The HSB must be removed from AUTO mode before performing this step, or it will start and run. This step can be performed without shutting off the utility service or turning off the utility breaker. After a full reboot of the ATS controller (approximately 6 minutes), the HSB can be returned to AUTO mode.

400A Installation

The following instructions are for installing two (2) 200A ATSs, allowing 400A service.

Primary ATS installed and connected to primary distribution panel as shown in the Installation Manual for the flex Controller® Automatic Transfer Switch (ATS), in “Wiring the ATS.”

Secondary ATS installed and connected to secondary distribution panel as shown below.

Models affected

- 201202
- 201039

HSB output (L1, L2, N, G) must be brought to a junction box (customer supplied) and split to supply both primary ATS and secondary ATS.

⚠ WARNING

Have only qualified personnel who are familiar with applicable codes, standards and regulations install and service the generator. ALWAYS comply with local, state, province, or territory and national electrical and building codes when installing the generator. NEVER alter the recommended installation in a way that would render the unit noncompliant with these codes. ALWAYS comply with regulations that Occupational Safety and Health Administration (OSHA) has established. ENSURE the generator is installed following the manufacturer's instructions.

⚠ DANGER

Gaseous fuels such as NG and LPG are highly explosive. Even the slightest spark can ignite such fuels and cause an explosion, which could cause burns, fire or explosion resulting in serious injury, property damage or even death. NO leakage is permitted.

⚠ WARNING

ALWAYS prevent the generator from starting while the covers are open. The generator may crank and start at any time without notice. Follow these steps in order:

1. Pull fuse from flex Controller® panel and secure with tape to the panel.
2. Disconnect the NEGATIVE, NEG or (-) battery cable first, and then remove the POSITIVE, POS or (+) battery cable.

To return the generator to service, follow these steps in order:

1. Connect the POSITIVE, POS or (+) battery cable first, and then connect the NEGATIVE, NEG or (-) battery cable.
2. Remove taped fuse from the panel and reinstall into the flex Controller®

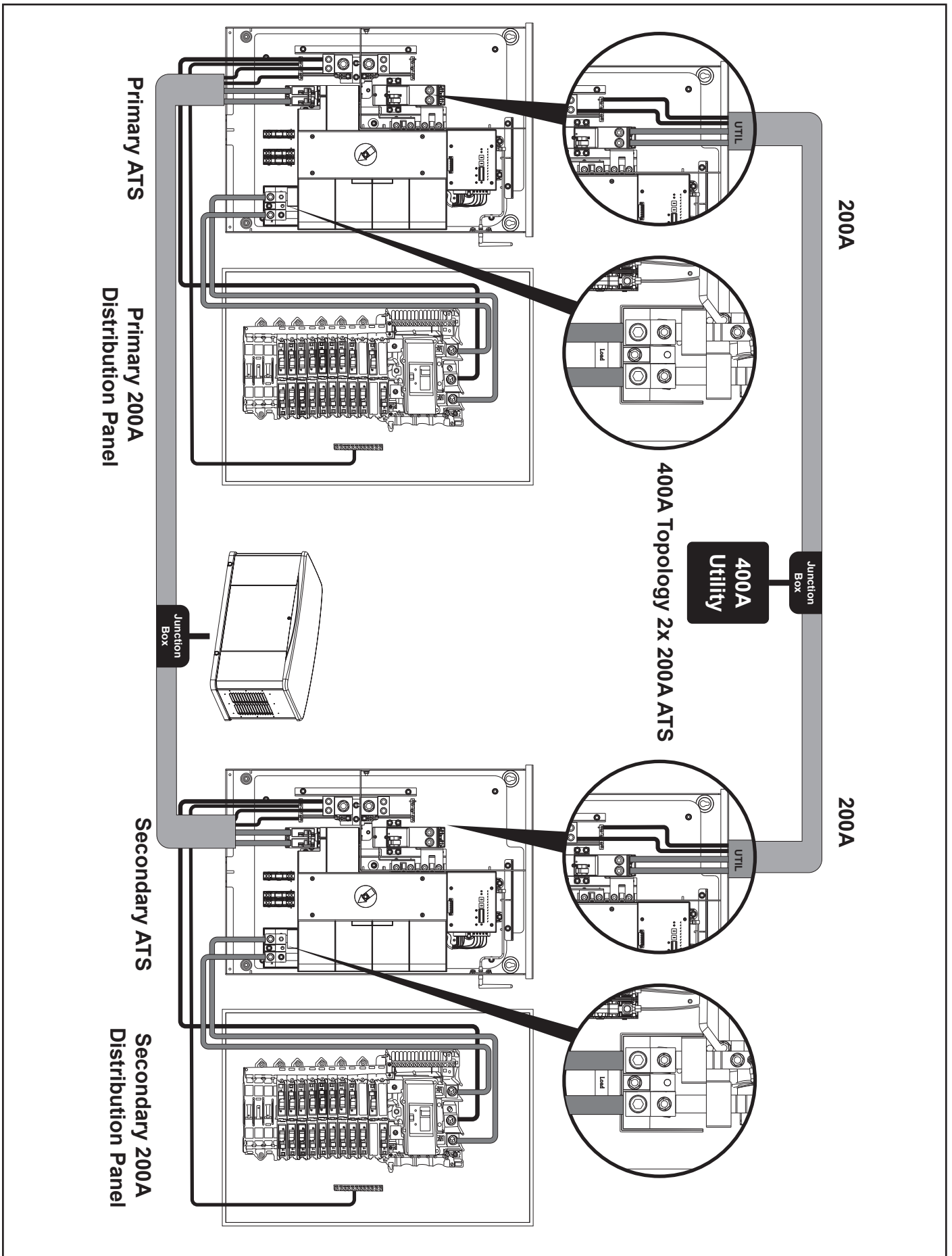

Primary ATS LEDs

1 - 8, 10 - 12 DIP switches are in "ON" position.

9 DIP switch is in the "OFF" position.

The LEDs will illuminate after utility power is supplied.

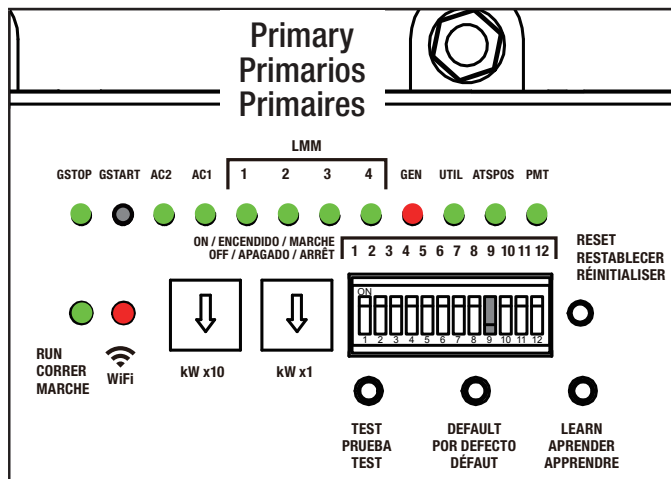

The LEDs shown pertain only to flex Controller® Load Management Modules (LMM).

Both LMM 1 through 4 (LMM1-4), GSTOP/ GSTART, and AC1/AC2 are not illuminated. This is normal and will occur when DIP switch 10 is in the OFF (Secondary ATS) position.

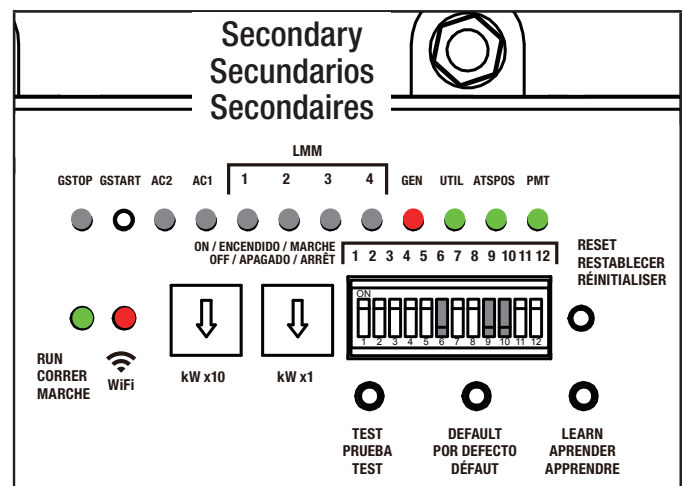

Secondary ATS LEDs

1 - 5, 7, 8 11 & 12 DIP switches are in "ON" position.

6, 9, 10 DIP switches are in the "OFF" position.

The LEDs will illuminate after utility power is supplied.

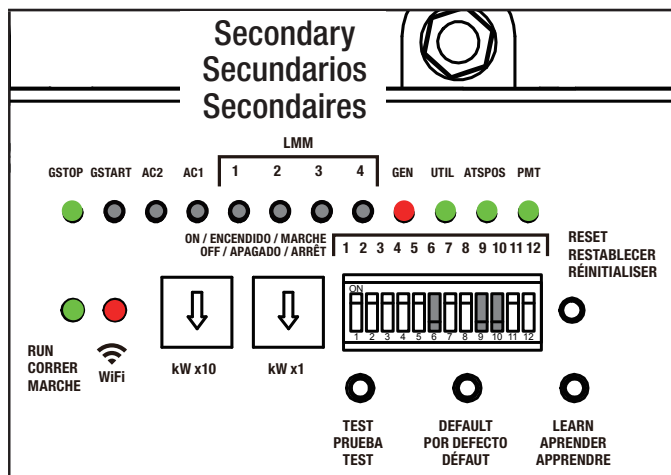

For support, see *Settings* on the *flex Controller®* section.

LMM modules can be attached to either primary or secondary distribution panel circuits but will be controlled only by primary ATS. LMM priority is determined by primary ATS and loads will be controlled as required per the settings input to primary ATS.

Primary ATS kW setting must match HSB rating. Primary ATS will communicate with secondary ATS to determine total load usage and determine need to activate LMM modules (if applicable).

When performing LEARN function for loads on LMMs; both primary and secondary ATS need to be active, but only the primary ATS is required to LEARN.

HSB is fully controlled by primary ATS. Starting and stopping along with exercise requirement commands are sent by primary ATS.

Wi-Fi connection should be made at install time to both primary and secondary ATS units to set day, date, time variables. Secondary ATS does not need exercise day, date, time set although it will not affect any operation if set.

HSB battery charge connection (120VAC) can come from either primary or secondary ATS or primary or secondary distribution panel. The connection should be fused with no greater than 15A regardless of source.

Low voltage AC1/AC2 or LMM connections can be made from either primary or secondary ATS. All secondary ATS AC1/AC2 or LMM connections are controlled by the primary ATS during generator operation.

Wi-Fi Setup Method

1. Use a Wi-Fi enabled device (laptop, smart phone, tablet, etc.) in near proximity to the ATS.
2. Search and connect to network name (SSID) "Champion ####" where #### will match the last four digits of the serial number that is printed on the control board.

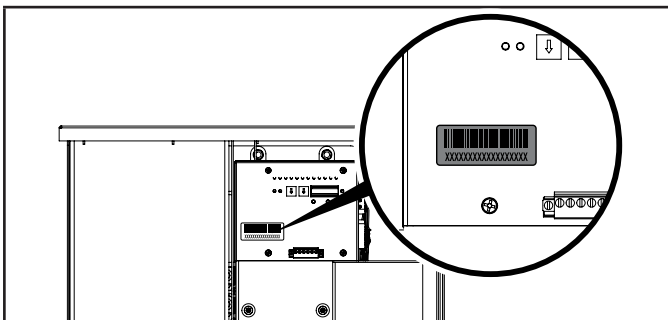

2a. The password for the network is located on a label on the dead front of the ATS.

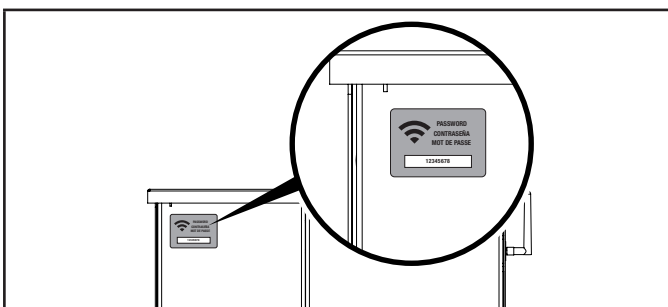

NOTICE

During the setup your device will disconnect from the internet. The Champion Wi-Fi is a direct connection between your device (laptop, smart phone, tablet, etc.) and the ATS, and it does not connect to the internet. Some Android devices may show the following screen – Choose "Connect only this time."



Internet may not be available.

If you want to connect this network without internet access, you can connect only this time or you can set your phone to always connect to it even if internet isn't available.

You can change this in Settings > Connections > Wi-fi > ADVANCED > Switch to mobile data > Network exceptions

[Connect only this time](#)
[Allow switch](#)
[Stay connected](#)

3. After connecting Wi-Fi, open your device's web browser. In the browser address change the address to 192.168.0.90 and begin search. This will direct your browser to the Champion flex Controller® Home Standby Generator Settings page located on the ATS. If your device's web browser does not load the Champion flex Controller® Home Standby Generator Settings Page but rather stays connected to the internet, turn off mobile data on the device (if applicable) and make sure the device is not connected to any other networks.

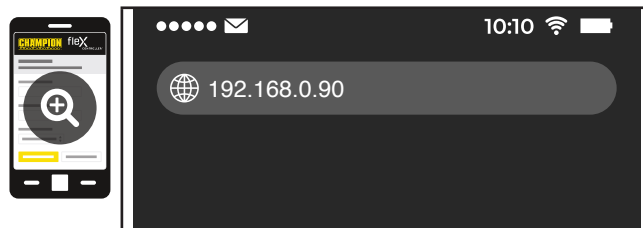

4. On the Champion flex Controller® Home Standby Generator Settings Page, set the date and time. Use either the dropdown boxes or the "USE THIS DEVICE DATE & TIME" button to set the time and date.

USE DEVICE DATE & TIME ⌄

Date:

Time:

CONFIRM DATE & TIME >

- Confirm and apply the settings before continuing. If you do not apply immediately, the clock will be later than actual. Unsaved changes are highlighted.

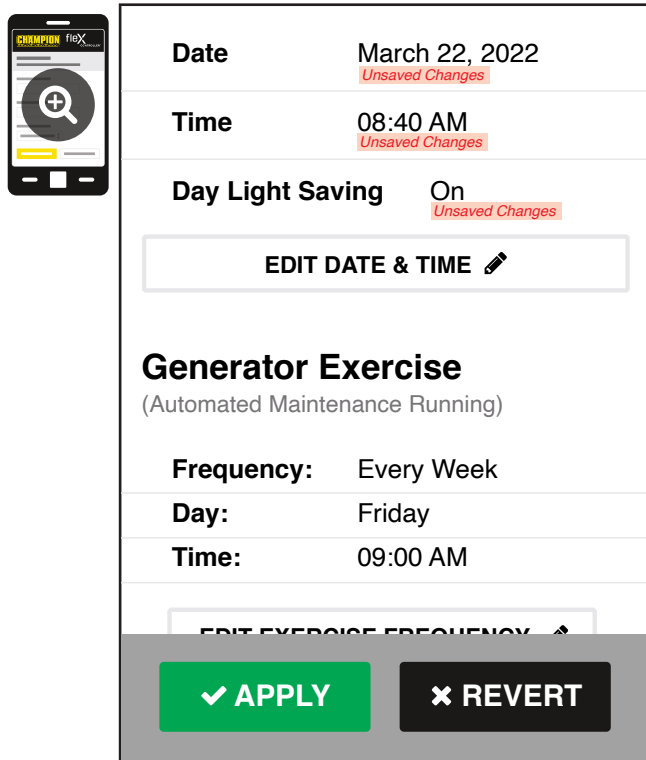

- Some operating systems will require additional steps to confirm update, accept all pop-up windows until progress bar is seen on screen.

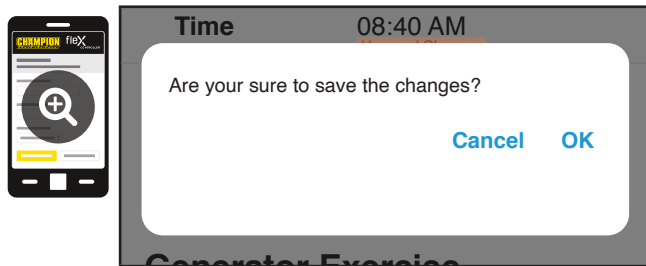

- Set the HSB exercise frequency and schedule.

NOTE: Exercise duration is system set at 15 minutes. The duration is not adjustable. The fleX Controller® must be in the AUTO mode in order to exercise.

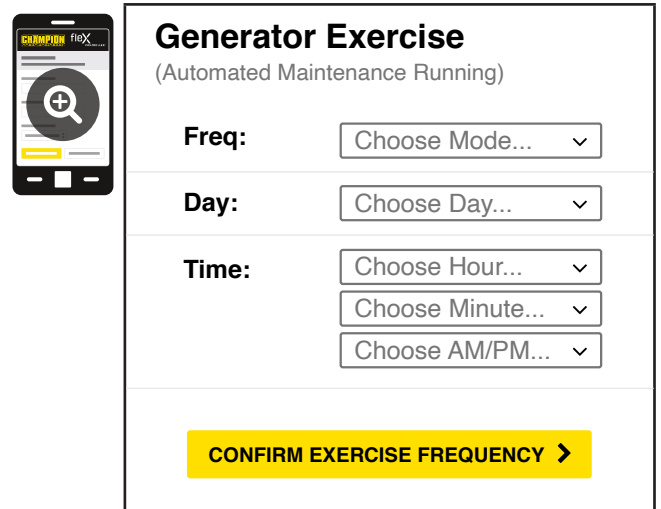

- Confirm and apply the settings before continuing. Unsaved changes are highlighted.

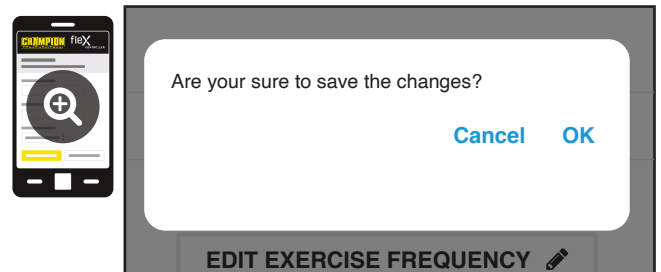
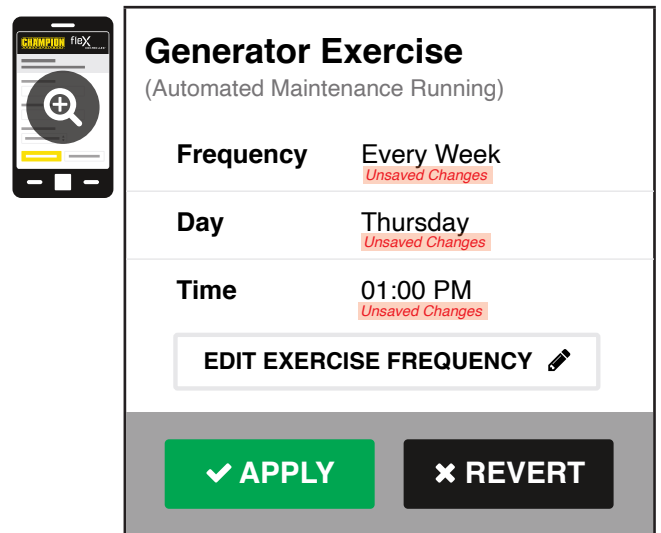

- Wireless network settings are not used at this time. The default values (shown below) should not be adjusted. Adjustment of this factory settings will require a certified electrician to correct.

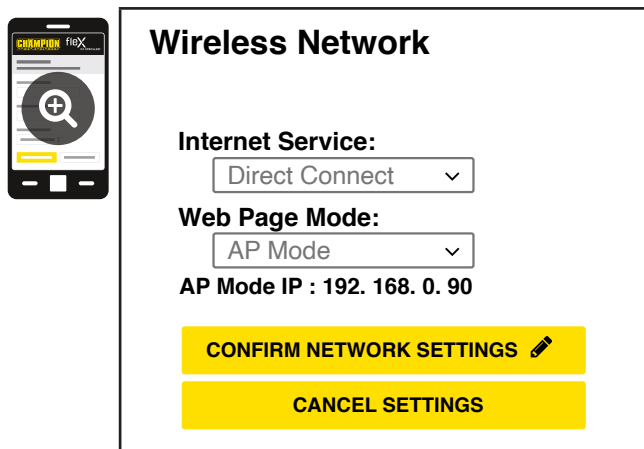

- The time, date, and exercise information have now been setup for the flex ATS and HSB. You can close your browser and disconnect from the ATS Wi-Fi, or skip to step 2 in the next section “ATS and HSB STATUS USING WIFI”.

ATS and HSB Status Using WIFI

- Using a WIFI enabled device, connect to the “Champion HSB” WIFI network following steps 1, 2, and 3 from WIFI Setup Method.
- After loading the Home Standby Generator Settings page, locate and click the icon at the bottom right corner of the page.
- You are now viewing the ATS and HSB status page. Items such as voltage, frequency, current, etc. can all be viewed for both utility and HSB power. All of the information is live. There are three tabs located at the top of the page. ATS, GEN, and LMM. Each tab will display the status for the Transfer Switch, Home Standby Generator, or Load Management Module(s) respectively.
- When finished viewing the status of the ATS, Generator, and LMM, close your browser and disconnect from the WIFI.

Connecting the Load Management Systems

If one or more LMM’s are being installed on the home, install them per the installation instructions included with the LMM before continuing.

BOND MODE (SYSTEM LEARNING MODE)

The BOND MODE MUST be completed between the HSB and ATS to operate as designed. Anytime you add or remove a flex device (e.g. when you add a new LMM or replace any control parts like the flex Controller in the HSB) you must go through BOND MODE for the entire system.

There are three methodologies for connecting the flex generator (HSB), flex automatic transfer switch (ATS) and flex load management module (LMM). One includes connecting a non-flex HSB to flex ATS and LMM. Please note the options and follow those instructions. Most common is option A.

- Complete Champion system (HSB, 1 ATS, LMMs)** – use this method if installing 1 ATS with the system. All 3 or more are part of the flex system.
- Complete Champion system (HSB, 2 ATS, LMMs)** – use this method if installing 2 ATS with the system. All 3 or more are part of the flex system.
- Partial Champion system (non-flex HSB, 1 ATS, LMMs)** – use this method if installing a non-flex HSB with two-wire start - only the ATS or LMMs or more are part of the flex system.
- A two-wire connection here refers to a signal circuit that runs between the flex Controller® ATS and the non-flex HSB. When installed in this configuration, the non-flex HSB will turn on and off based on the signal it is receiving from the flex ATS. The two-wire signal from the flex Controller® ATS is connected to 2-wire (START) and COM (Ground) to a non-flex HSB. Refer to wiring diagram of the non-flex HSB on how to create the circuit.
 - Complete Champion system (HSB, 1 ATS, LMMs)**
 - Confirm the generator (HSB), automatic transfer switch (ATS) and load management module (LMM) are wired correctly.
 - Confirm the ATS flex Controller two circular pots that are located to the left of the DIP switches match the rated power output of the generator for your fuel type.
 - To begin programming, disable AUTO by pressing OFF. The screen should show OFF, then press and hold OK for 3 seconds to enter SETTINGS.

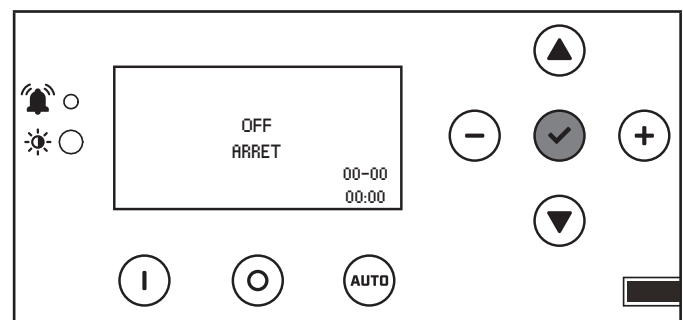

4. Click + until you reach USER SETTINGS.

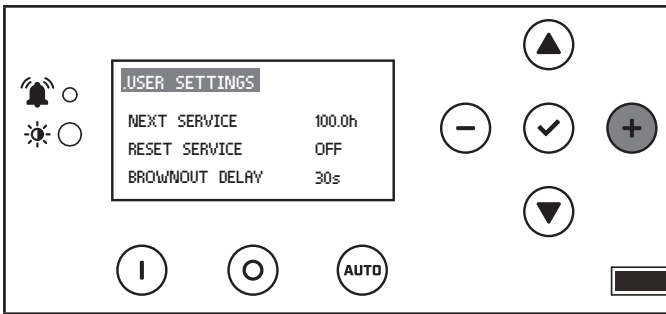

5. Scroll down until you reach BOND MODE. Press OK to select, cursor will move to the right. Then use a combination of up/down to adjust ON. Press OK to finish.

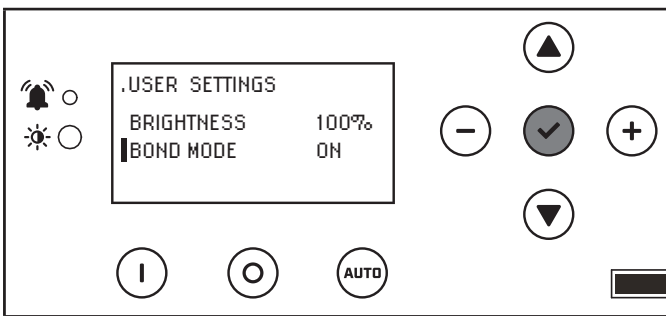

6. After BOND MODE is adjusted, use up/down to return to USER SETTINGS and hold OK for 3 seconds to exit.

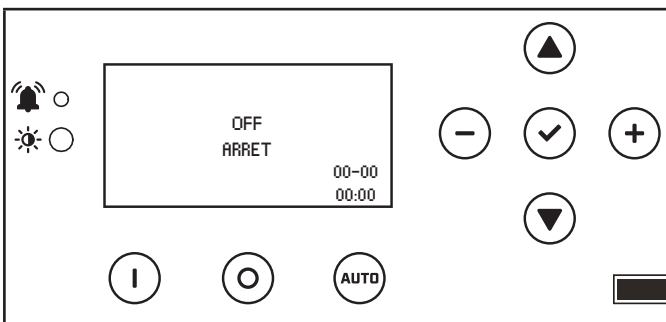

7. On the ATS, turn the utility breaker "OFF" and the generator circuit breaker "ON"

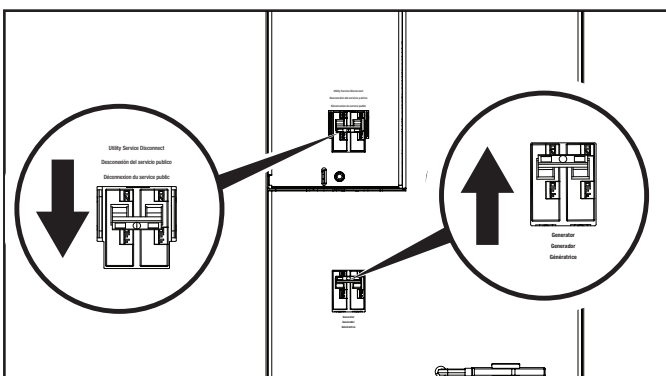

8. Set the flex Controller® in the MANUAL or AUTO mode. The HSB will crank and start.

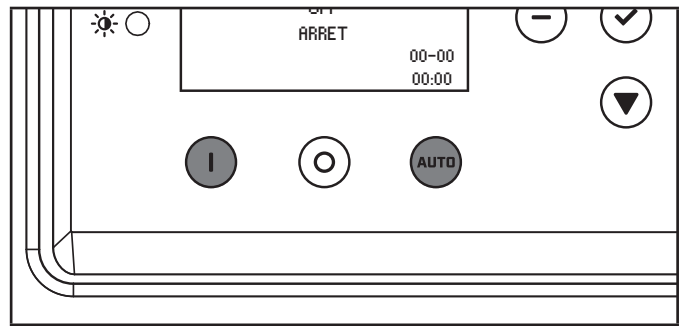

9. If you are not installing an LMM, skip to step 13.

10. After the ATS switches to generator power, and the LMMs are powered by the generator (LEDs 1-4 will be red), use a small flat head screwdriver to adjust the LMM DIP switches 3 and 4 to the "ON" position.

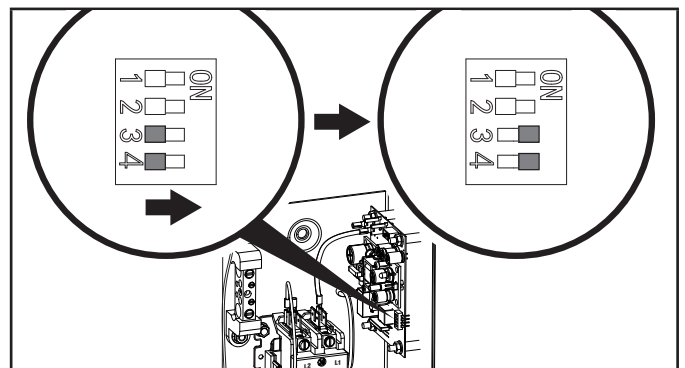

NOTICE

If the LMM DIP switches 3 and 4 are already in "ON" move the to "OFF" for 1 second, then move back to "ON."

11. At this point, the HSB and LMM are now in BOND MODE and ready to bond to the ATS. If there is more than one LMM, move all DIP switches 3 and 4 to the "ON" position.

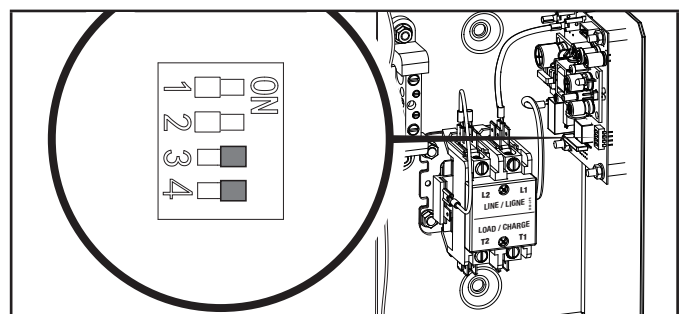

12. After the BOND MODE is activated, the Flex LMM will exit the BOND MODE automatically, but the DIP switches 3 and 4 still need to be moved to "OFF" manually once the process is complete: LMM LEDs 1-4 are ON.

13. Press and hold “LEARN” button of ATS for about 8 seconds or until you see the lights flash green, thereby entering SYSTEM LEARNING MODE. The ATS will send its UUID code information to the HSB (and LMMs if applicable) to bond them together. LEDs on ATS will blink to start process (and LMM 1-4 if applicable) will be ON when process is complete. This may take up to 15 minutes.

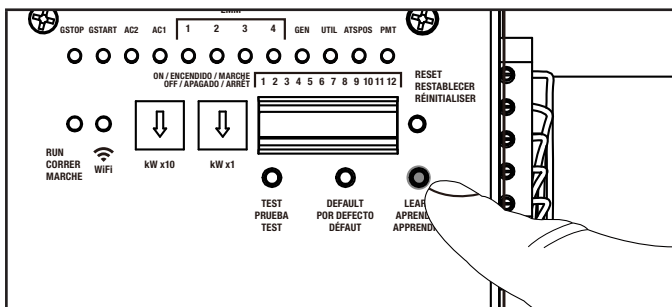

14. flex Controller® LEDs will flash multiple times green red indicating learn is complete. See CONFIRMING BOND MODE section to verify.

B. Complete Champion system (HSB, 2 ATS, LMMs)

1. Confirm the generator (HSB), automatic transfer switch (ATS) and load management module (LMM) are wired correctly.
2. Confirm the ATS flex Controller two circular pots that are located to the left of the DIP switches match the rated power output of the generator for your fuel type.
3. To begin programming, disable AUTO by pressing OFF. The screen should show OFF, then press and hold OK for 3 seconds to enter SETTINGS.

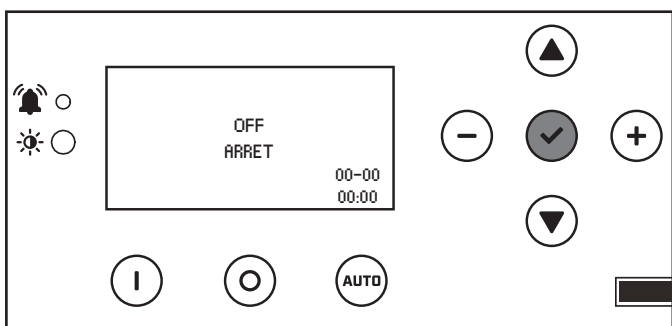

4. Click + until you reach USER SETTINGS.

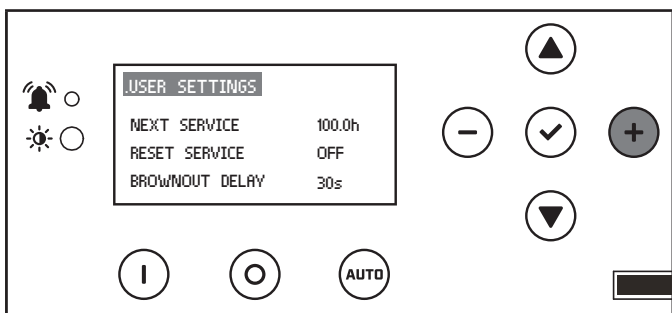

5. Scroll down until you reach BOND MODE. Press OK to select, cursor will move to the right. Then use a combination of up/down to adjust ON. Press OK to finish.

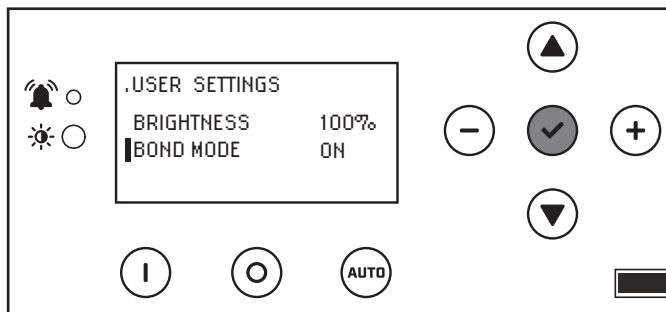

6. After BOND MODE is adjusted, use up/down to return to USER SETTINGS and hold OK for 3 seconds to exit.

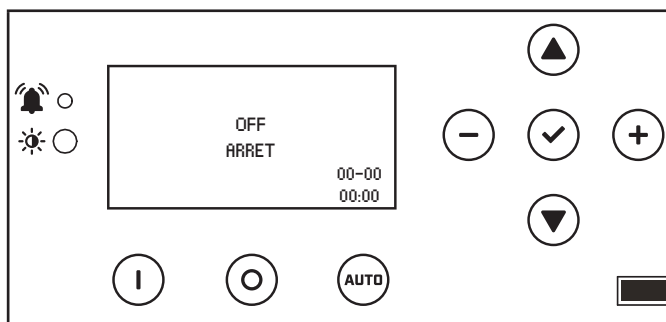

7. On the ATS, turn the utility breaker “OFF” and the generator circuit breaker “ON”

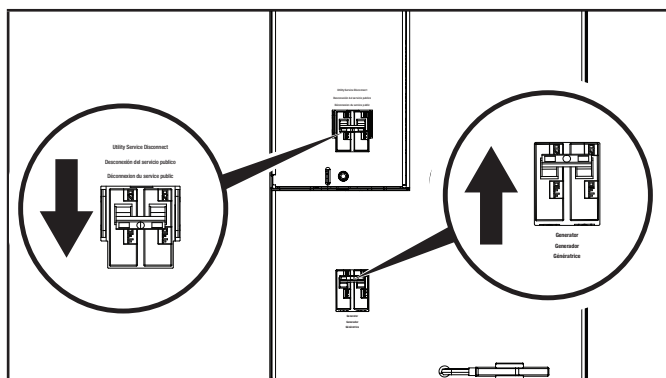

8. Set the flex Controller® in the MANUAL or AUTO mode. The HSB will crank and start.

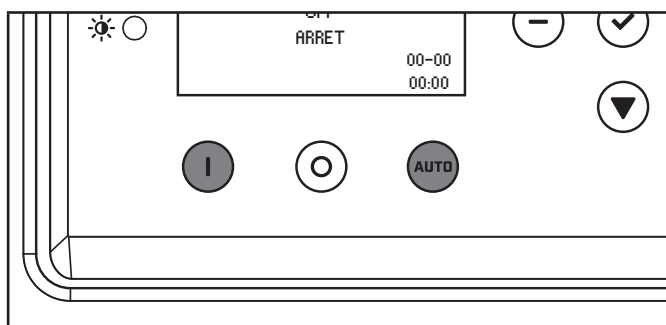

9. After BOTH (primary and secondary) ATS switch to generator power, and the LMMs are powered by the generator, use a small flat head screwdriver to adjust the LMM DIP switches 3 and 4 in “ON” position. Do this for all the LMMs in service.

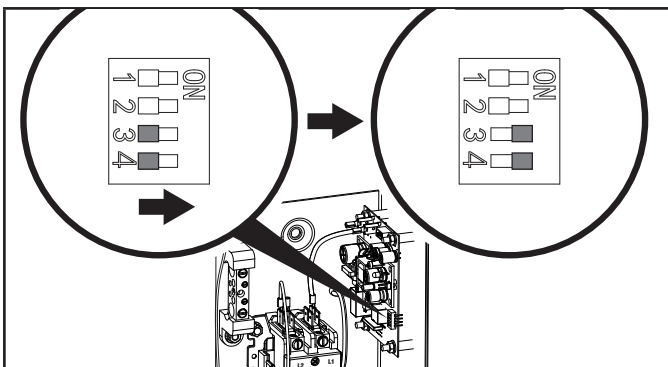

NOTICE
If the LMM DIP switches 3 and 4 are already in “ON” move the to “OFF” for 1 second, then move back to “ON.”

10. At this point, the LMM is now in BOND MODE and ready to bond to the ATS.

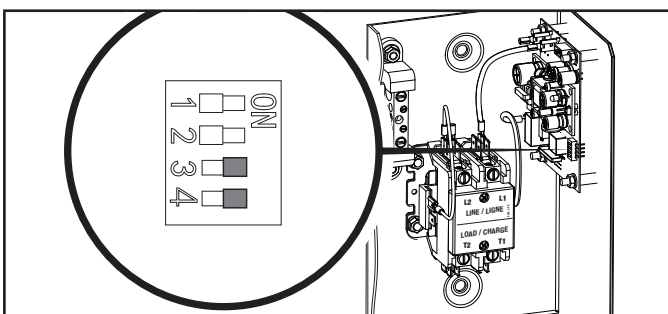

11. If there are more than one LMM, move each DIP switch 3 and 4 to “ON.”

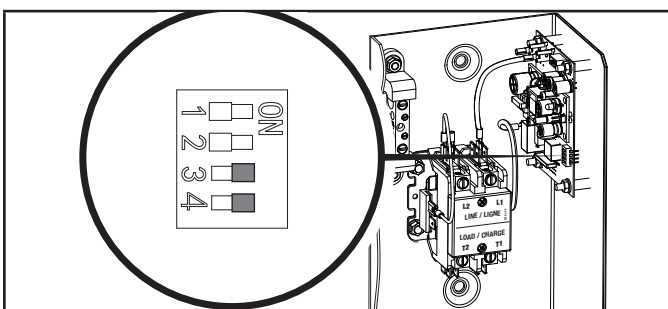

12. After the BOND MODE is activated, the Flex LMM will exit the Bond Mode automatically, but the DIP switches 3 and 4 still need to be moved to “OFF” manually after the process is complete (LEDs 1-4 are lit on the ATS flex Controller).

13. Adjust the secondary ATS DIP switch 6 to “OFF.” The secondary ATS is now in BOND MODE, and ready to be bonded to the primary ATS.

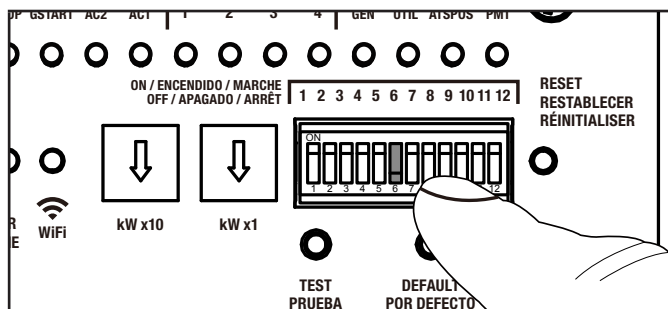

14. Press and hold “LEARN” button of ATS for about 8 seconds or until you see the lights flash green, thereby entering SYSTEM LEARNING MODE. The ATS will send its UUID code information to the HSB (and LMMs if applicable) to bond them together. LEDs on ATS will blink to start process (and LMM 1-4 if applicable) will be ON when process is complete. This may take up to 15 minutes.

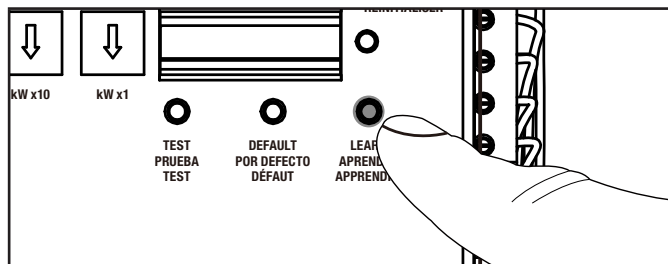

15. flex Controller® LEDs will flash multiple times green red indicating learn is complete. See CONFIRMING BOND MODE section to verify.

C. Partial Champion system (non-flex HSB, 1 ATS, LMMs)

1. Confirm the non-flex generator (HSB), automatic transfer switch (ATS) and load management module (LMM) are wired correctly.
2. Confirm the ATS flex Controller two circular pots that are located to the left of the DIP switches match the rated power output of the generator for your fuel type.
3. Power on the non-flex HSB controller and put in STOP mode. See HSB instruction manual for more details.
4. On the flex ATS, turn the utility breaker “OFF” and the generator circuit breaker “ON”

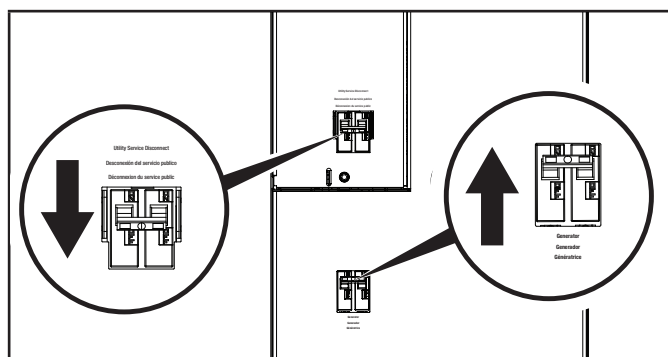

- Set the non-flex HSB controller in the MANUAL or AUTO mode. The HSB will crank and start. See HSB instruction manual for more details.
- After the ATS switches to generator power, and the LMMs are powered by the generator (LEDs 1-4 will be red), use a small flat head screwdriver to adjust the LMM DIP switches 3 and 4 in "ON" position..

- After the BOND MODE is activated, the Flex LMM will exit the Bond Mode automatically, but the DIP switches 3 and 4 still need to be moved to "OFF" manually.
- Press and hold "LEARN" button on the ATS for about 8 seconds, thereby entering SYSTEM LEARNING MODE. The ATS will send its UUID code information to the HSB (and LMMs if applicable) to bond them together. LEDs on ATS will blink to start process (and LMM 1-4 if applicable) will be ON when process is complete. This may take up to 15 minutes.

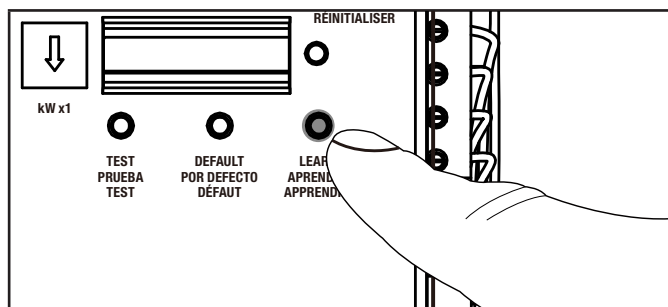
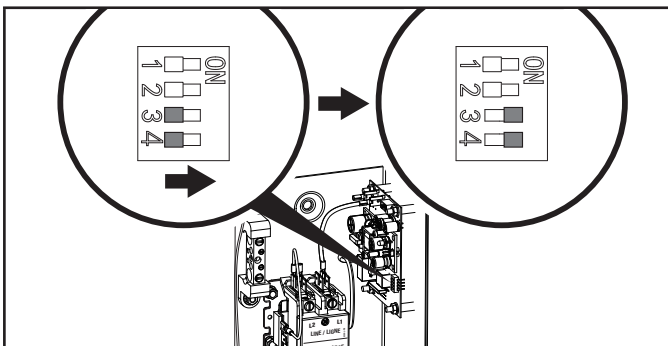

NOTICE
If the LMM DIP switches 3 and 4 are already in "ON" move the to "OFF" for 1 second, then move back to "ON."

- At this point, the LMM is now in BOND MODE and ready to bond to the ATS.

- flex Controller® LEDs will flash multiple times green red indicated learn is complete. See CONFIRMING BOND MODE section to verify.

CONFIRMING BOND MODE

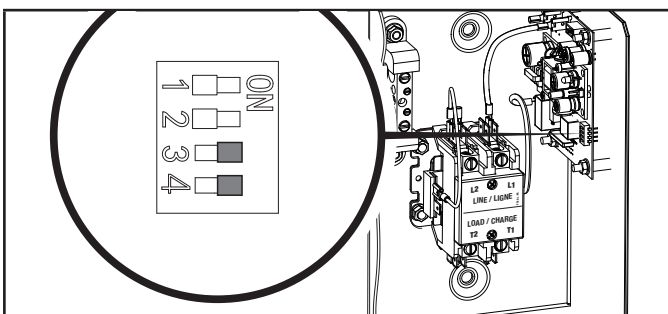

- Complete Champion system (HSB, 1 ATS, LMMs)** – check BOND MODE per below.
- Complete Champion system (HSB, 2 ATS, LMMs)** – check BOND MODE per below.
- Partial Champion system (non-flex HSB, 1 ATS, LMMs)** – unable to check BOND MODE.

- If there are more than one LMM, move each DIP switch 3 and 4 to "ON."

- As soon as you Press and hold "LEARN" button of ATS for about 8 seconds, thereby entering SYSTEM LEARNING MODE, the HSB flex Controller will display power direction icons. If BOND MODE was not successful, the HSB flex Controller® will remain OFF.

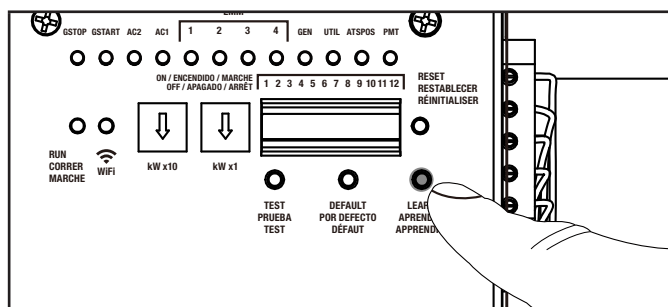
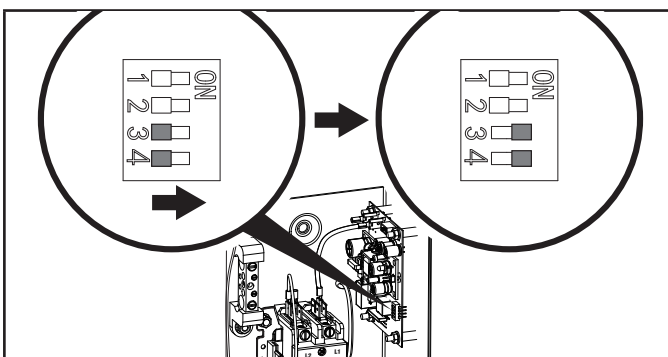

Successful BOND

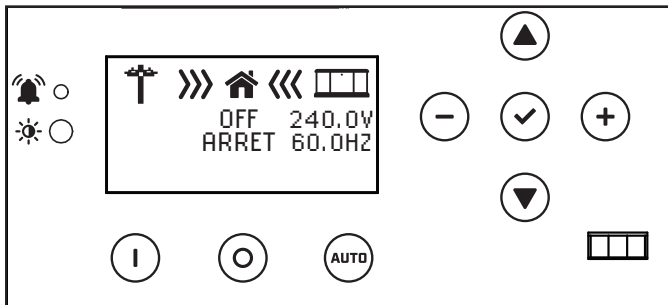

Unsuccessful BOND

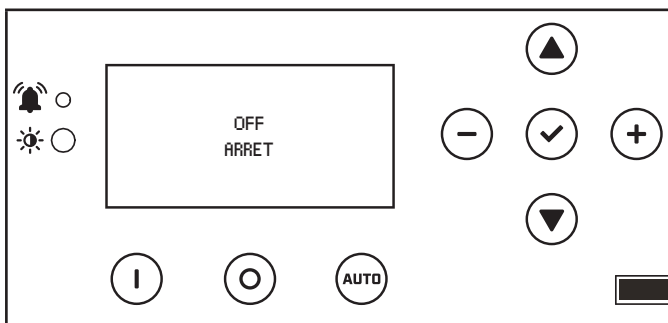

- Alternatively, you can confirm through Wi-Fi provided the ATS is connected per “Wi-Fi Setup Method” in this manual. Once you have confirmed the ATS is connected to Wi-Fi, and you have successfully negotiated setup, search and connect to network name (SSID) “Champion #####” where ##### will match the last four digits of the serial number that is printed on the control board. After connecting to Wi-Fi, open your device’s web browser. In the browser address change the address to 192.168.0.90 and begin search. This will direct your browser to the Champion flex Controller® Home Standby Generator Settings page located on the ATS.

Navigate to the LMM page and you will note each LMM registers 0 kW as shown



ATS	GEN	LMM	Event
Revision			
LMM Relay0 Demand:	0.00kW		
LMM Relay1 Demand:	0.00kW		
LMM Relay0 Demand:	0.00kW		
LMM Relay3 Demand:	0.00kW		
Load AC1 Demand:	0.00kW		
Load AC2 Demand:	0.00kW		

LOAD TEACHING SYSTEM

After installation and wiring are complete teach the ATS which loads are attached by the following procedure. Teaching the system is only required if 1 or more LMM’s were installed OR if AC1 OR if AC2 is being used to manage loads.

- Turn flex Controller® ATS UTILITY circuit breaker to the OFF position. Generator will start and run automatically.
- Confirm managed loads are all operating.
- Press and hold the button marked “LEARN” for 8 seconds. ATS will turn off all loads, and then turn on one load at a time until all loads are turned on. Then, the ATS will shutoff all managed loads one at a time until all are OFF. The ATS will flash LEDs indicating function in process. LMM1-LMM4 LEDs are separated by about 15 seconds. A green flashing light indicates learning was successful. A red flashing light indicates an overload has occurred.
- After ATS has learned all loads the LMM units will be returned to normal operation.
- Installation configuration is now held in memory and will not be affected by power outage.
- Return UTILITY circuit breaker to the ON position. ATS will transfer load back to utility and generator will cool down and shut off.
- Repeat this process if LMM units are added or removed from the system.

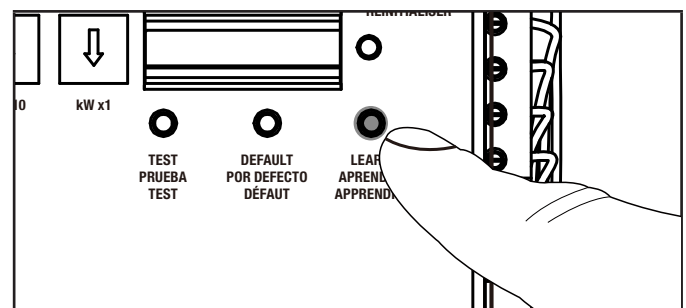

Full System Check

- Please ensure BOND MODE has been completed before final system check.
- Open Utility breaker for full system test, close breaker after confirming all systems working.
- After Utility breaker opens engine will start automatically.
- flex ATS will reboot on Generator power and control switching of latching relays.
- Home is now powered by Generator. If Load Management modules (LMM) have been installed, please allow 5 minutes for LMM and AC1/AC2 to become active.
- Perform Load Learning through ATS panel at this time. LMM units will be dropped and reacquired in order.

7. Close Utility breaker. The ATS will transfer back to Utility and Generator will begin shutdown cycle.
8. System is now fully functional.
9. Put the fleX Controller® to the previous position (either MANUAL or AUTO for example). Confirm utility power is active, utility side relay is closed, and home is receiving power.
10. Return to HSB and verify the controller is in "AUTO" mode. Confirm icons indicate Utility power is active, Utility side relay is closed, and home is receiving power.
11. Close and lock HSB hoods return keys to customer.

NEMA 1 – This type of enclosed ATS is for indoor installations only.

NEMA 3R – This type of enclosed ATS is similar to the indoor box, except that it is a weatherproof enclosure and required for exterior installations by code. The enclosure only has knockouts on the bottom side for the enclosure, requires water tight fasteners/ grommets when installed outside per code. This enclosure can also be used inside.

SPECIFICATIONS

Model	201020	201355	201039
Service Rating	Service Entry Rating		
Enclosure Style	Type 3R Outdoor*		
Maximum Amps	100	150	200
Nominal Volts	120/240		
Transition Type	Open transition, break before make		
ETL Listed - Conforms to	CSA Std. C22.2 NO. 100 UL Std. NO. 1008		
Load Management Circuits	4		
Length	29.9 in. (76 cm)	29.9 in. (76 cm)	29.9 in. (76 cm)
Width	20.8 in. (52.8 cm)	20.8 in. (52.8 cm)	20.8 in. (52.8 cm)
Height	8 in. (20.3 cm)	8 in. (20.3 cm)	8 in. (20.3 cm)
Weight	62 lb. (28.2 kg)	62 lb. (28.3 kg)	62 lb. (28.3 kg)

Technical Specifications

- 22kAIC, no short-time current rating.
- Suitable for use in accordance with Article 702 of the National Electric Code, NFPA 70.
- Suitable for use as service equipment NORMAL source only. Additional disconnect must be readily available for the alternate source unless the alternate source is an accessible generator and can be readily shut down.
- Suitable for control of motors, electrical discharge lamps, tungsten filament lamps, and electrical heating equipment where the sum of the motor full load ampere rating and the ampere rating of other loads does not exceed the ampere rating of the switch. Tungsten load not to exceed 30% of the switch rating.
- Continuous load not to exceed 80% of switch rating.
- Wiring to generator must be enclosed in conduit.

Short-circuit withstand and closing ratings

- This transfer switch is suitable for use in a circuit capable of delivering the short circuit for the maximum voltage as marked below:

	Short-Circuit current (RMS symmetrical amps X 1000)	Volts (Volts AC maximum)
Utility	22	240
Generator	10	240

Wire - Lug Rating - Torque

	Load	Neutral	Ground	Utility
AWG (gauge)	min 1 – max 000			See circuit breaker markings.
Lug Rating	250-14 AL9CU	350-6 AL9CU	1/0-14 AL9CU	
Torque (lbf-in/Nm)	275 / 31			

Type 3R Outdoor – This type of enclosed ATS is a weatherproof enclosure and required for exterior installations by code. The enclosure has knockouts on the bottom and side, and requires water tight connections when installed outside per code. This enclosure can also be used inside.

201020 ATS Wiring Diagram

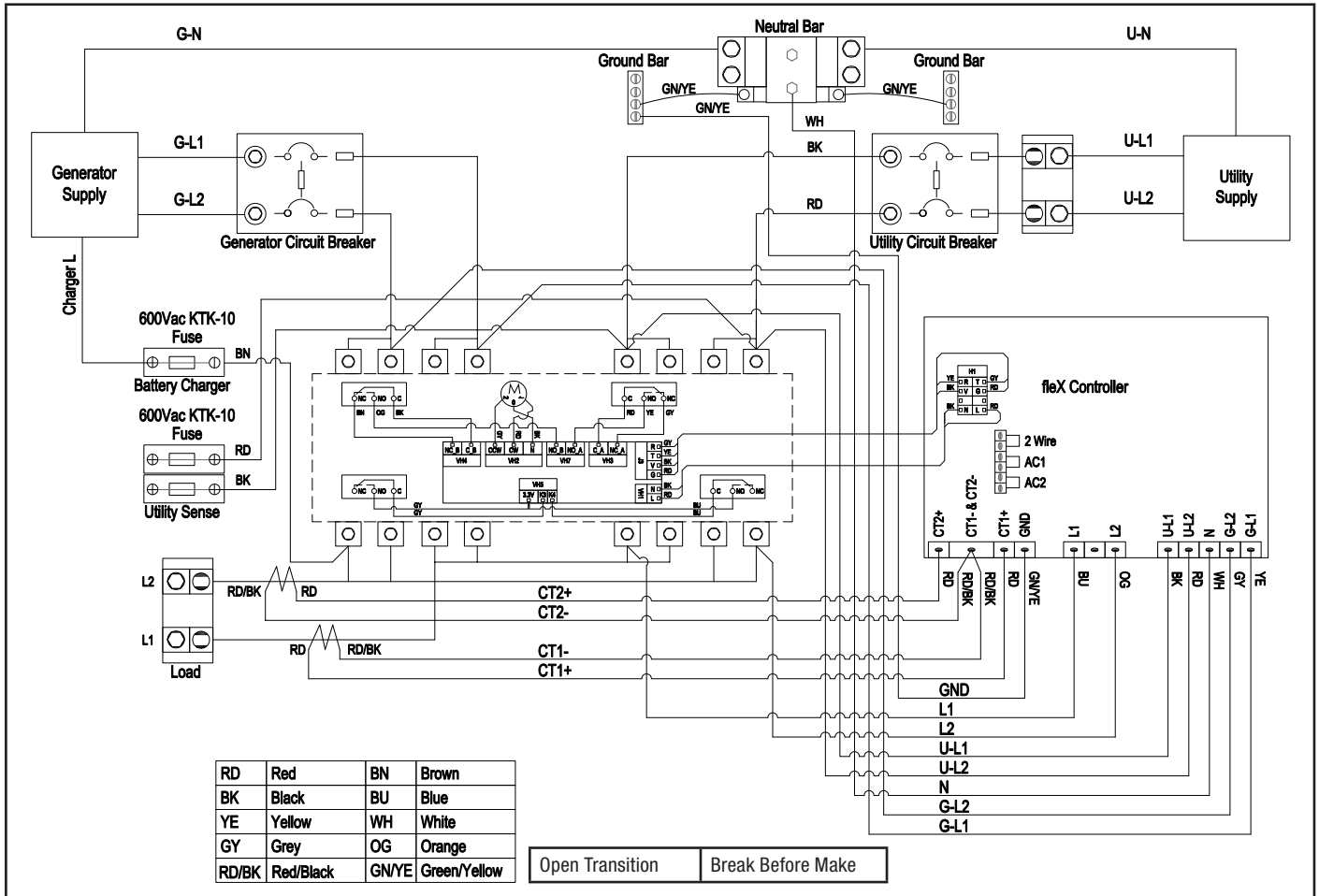

201039 ATS Wiring Diagram

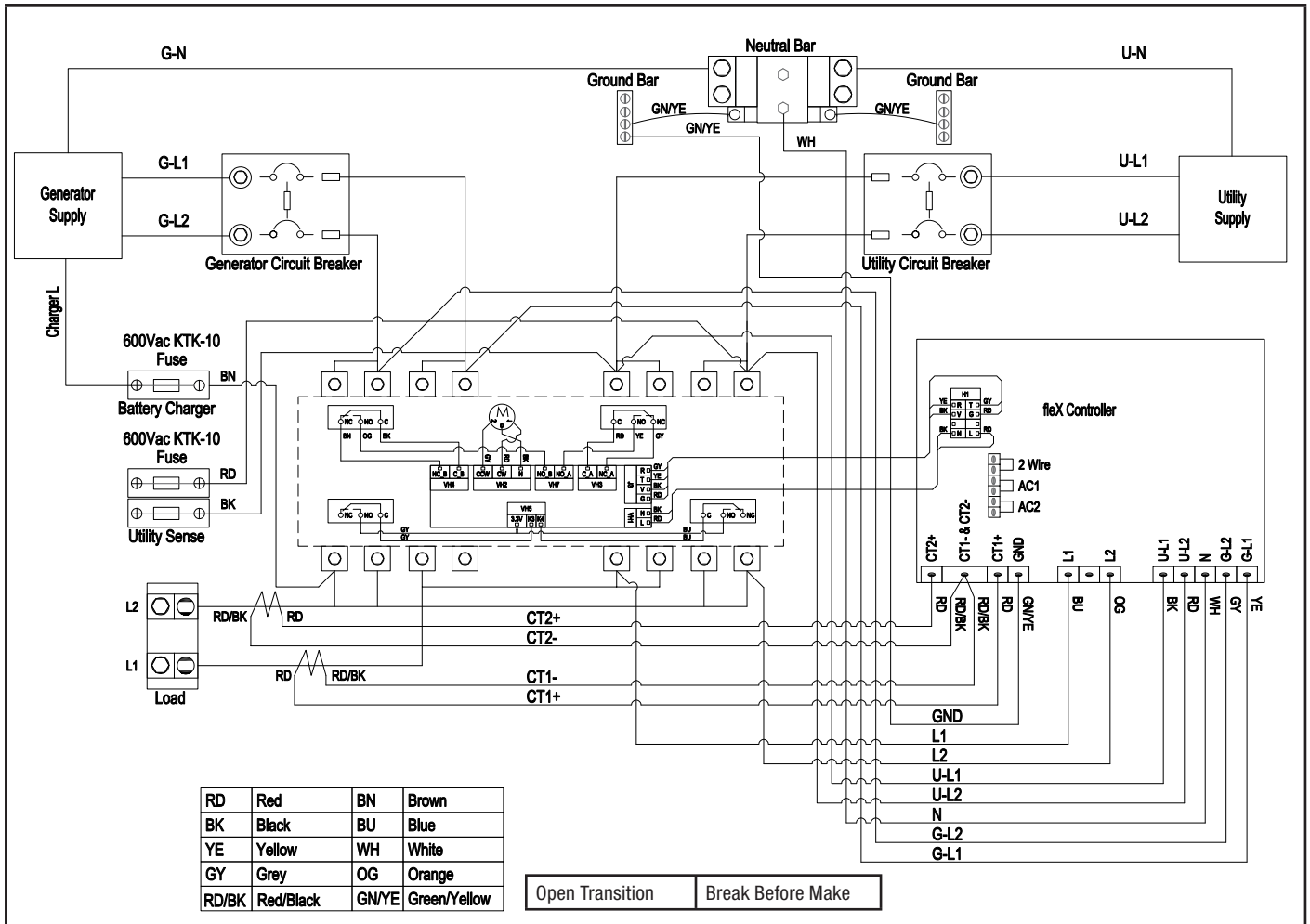

201355 ATS Wiring Diagram

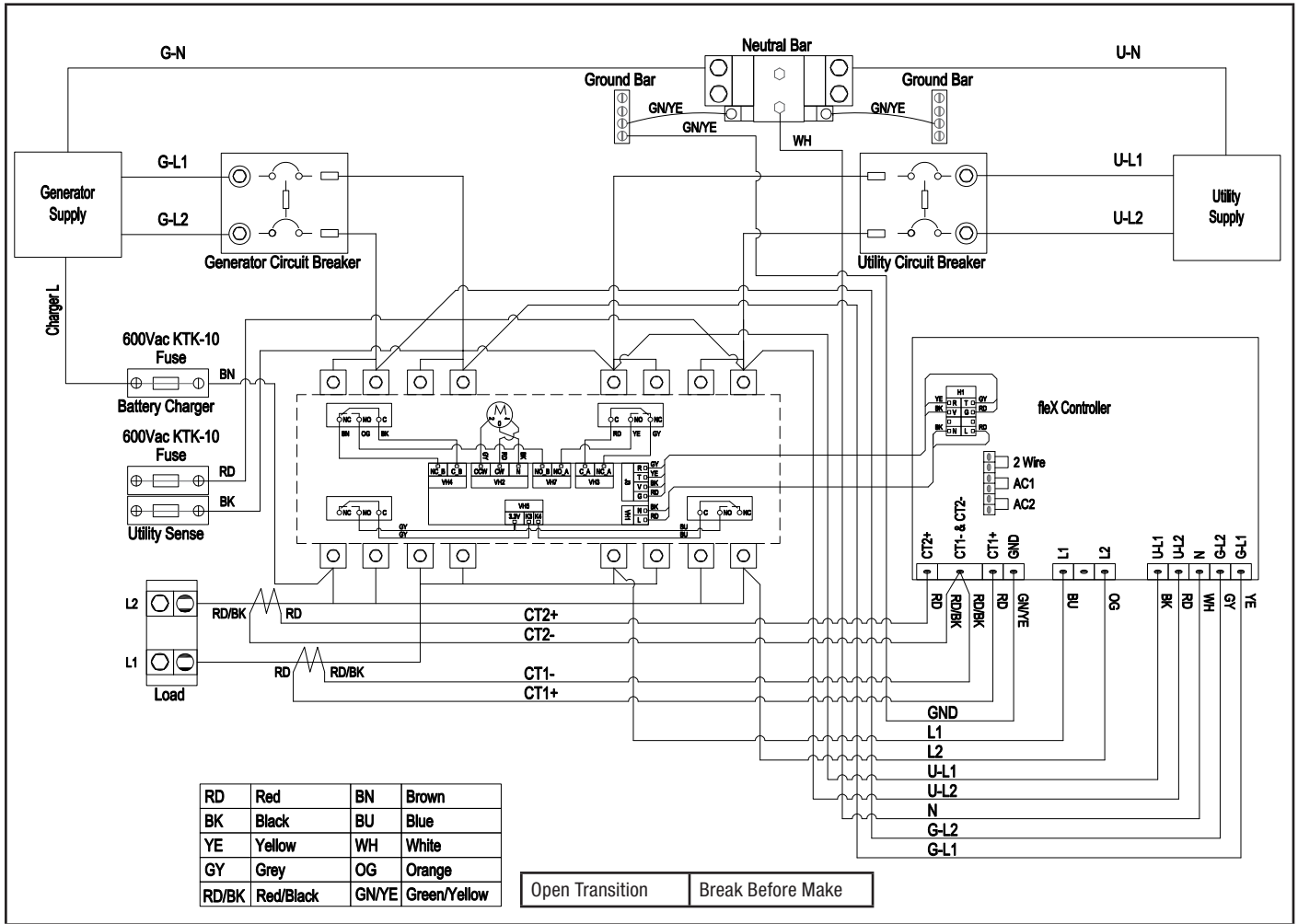

WARRANTY

Each Champion transfer switch or accessory is guaranteed against mechanical or electrical failure due to manufacturing defects for a period of **24 months** following shipment from the factory. The manufacturer's responsibility during this warranty period is limited to repair or replacement, free of charge, of products proving defective under normal use or service when returned to the factory, transportation charges prepaid. Guarantee is void on products that have been subjected to improper installation, misuse, alteration, abuse or unauthorized repair. The manufacturer makes no warranty with respect to the fitness of any goods for a user's particular application and assumes no responsibility for proper selection and installation of its products. This warranty is in lieu of all other warranties, expressed or implied, and limits the manufacturer's liability for damages to the cost of the product. This warranty gives you specific legal rights, and you may have other rights, which vary from state to state.

WARRANTY*

CHAMPION POWER EQUIPMENT
2 YEAR LIMITED WARRANTY

Warranty Qualifications

To register your product for warranty and FREE lifetime call center technical support please visit:

<https://www.championpowerequipment.com/register>

To complete registration you will need to include a copy of the purchase receipt as proof of original purchase. Proof of purchase is required for warranty service. Please register within ten (10) days from date of purchase.

Repair/Replacement Warranty

CPE warrants to the original purchaser that the mechanical and electrical components will be free of defects in material and workmanship for a period of two years (parts and labor) from the original date of purchase and 180 days (parts and labor) for commercial and industrial use. Transportation charges on product submitted for repair or replacement under this warranty are the sole responsibility of the purchaser. This warranty only applies to the original purchaser and is not transferable.

Do Not Return The Unit To The Place Of Purchase

Contact CPE's Technical Service and CPE will troubleshoot any issue via phone or e-mail. If the problem is not corrected by this method, CPE will, at its option, authorize evaluation, repair or replacement of the defective part or component at a CPE Service Center. CPE will provide you with a case number for warranty service. Please keep it for future reference. Repairs or replacements without prior authorization, or at an unauthorized repair facility, will not be covered by this warranty.

Warranty Exclusions

This warranty does not cover the following repairs and equipment:

Normal Wear

Products with mechanical and electrical components need periodic parts and service to perform well. This warranty does not cover repair when normal use has exhausted the life of a part or the equipment as a whole.

Installation, Use and Maintenance

This warranty will not apply to parts and/or labor if the product is deemed to have been misused, neglected, involved in an accident, abused, loaded beyond the product's limits, modified, installed improperly or connected incorrectly to any electrical component. Normal maintenance is not covered by this warranty and is not required to be performed at a facility or by a person authorized by CPE.

Other Exclusions

This warranty excludes:

- Cosmetic defects such as paint, decals, etc.
- Wear items such as filter elements, o-rings, etc.
- Accessory parts such as storage covers.
- Failures due to acts of God and other force majeure events beyond the manufacturer's control.
- Problems caused by parts that are not original Champion Power Equipment parts.

Limits of Implied Warranty and Consequential Damage

Champion Power Equipment disclaims any obligation to cover any loss of time, use of this product, freight, or any incidental or consequential claim by anyone from using this product. THIS WARRANTY IS IN LIEU OF ALL OTHER WARRANTIES, EXPRESS OR IMPLIED, INCLUDING WARRANTIES OF MERCHANTABILITY OR FITNESS FOR A PARTICULAR PURPOSE.

A unit provided as an exchange will be subject to the warranty of the original unit. The length of the warranty governing the exchanged unit will remain calculated by reference to the purchase date of the original unit.

This warranty gives you certain legal rights which may change from state to state or province to province. Your state or province may also have other rights you may be entitled to that are not listed within this warranty.

Contact Information

Address

Champion Power Equipment, Inc.
6370 S Pioneer Way, Unit 101
Las Vegas, NV 89113 USA
www.championpowerequipment.com

Customer Service

Toll Free: 1-877-338-0999
info@championpowerequipment.com
Fax no.: 1-562-236-9429

Technical Service

Toll Free: 1-877-338-0999
tech@championpowerequipment.com
24/7 Tech Support: 1-562-204-1188