



OPERATOR'S MANUAL

MODEL #201202
22-kW HOME STANDBY GENERATOR
WITH flex CONTROLLER™



ACTIVATE YOUR WARRANTY

by registering your product:
championpowerequipment.com

SERIAL NO.



Intertek



1-877-338-0999

or visit championpowerequipment.com

SAVE THESE INSTRUCTIONS. This manual contains important safety precautions which should be read and understood before operating the product. Failure to do so could result in serious injury. This manual should remain with the product.

Specifications, descriptions and illustrations in this manual are as accurate as known at the time of publication, but are subject to change without notice.

No part of this publication may be reproduced or used in any form by any means – graphic, electronic or mechanical, including photocopying, recording, taping or information storage and retrieval systems – without the written permission of Champion Power Equipment (CPE).

Have questions or need assistance?
Do not return this product to the store!

WE ARE HERE TO HELP!

Visit our website:

www.championpowerequipment.com

for more info:

- Product Info & Updates
- Product Registration
- Frequently Asked Questions
- Tech Bulletins

- or -

**Call our Customer Care Team Toll-Free at:
1-877-338-0999**

This manual must be used with Champion Power Equipment (CPE) manuals:

Installation Manual

Transfer Switch Manual

**We are always working to improve our products. Therefore, the enclosed product may differ slightly from the image on the cover.*

TABLE OF CONTENTS	
Introduction	4
Home Standby Generator	4
Safety	4
Safety Definitions	4
Important Safety Instructions	5
Carbon Monoxide Hazards	5
Installation Hazards	6
Before Starting	6
Operation Hazards	6
Accidental Starting	7
Electrical Shock Hazards	7
Fuel Safety	7
Burn Hazards	8
Entanglement Hazards	8
Battery Hazards	8
Safety Symbols	9
Safety Labels and Hang Tags	11
Safety label and Hang Tag locations	13
General Information	14
Component Identification - Home Standby (HSB) Generator	14
Component Identification - Engine	15
Operation Symbols	16
Control Panel	17
FCC Statement	17
Industry Canada: CAN ICES-002/NMB-002	17
Industry Canada: ICES-003/NMB-003	17
fleX Controller™	18
State	19
User Settings	20
Status Icons	22
Transfer Power Direction	23
Information Icons	23
Fault Icons	24
Fault Protection	28
Fault Code Reset	28
Wi-Fi Setup Method	29
ATS and HSB Status Using WIFI	31
Programming fleX Controller™	32
Setting System Time	34
Setting Exercise Time	35
Setting Brownout Delay	35
Setting Power Line Carrier (PLC)	36
Emission Requirements	37
Specifications	38
Fuel System	39
Battery Requirements	39
Battery Charging	40
Model and Serial Number	41
Operation	41
High Altitude	41
Enclosure and Access	41
Pre-Start Checklist	43
Turning OFF the Generator	43
Maintenance	43
Scheduled Maintenance Chart	43
Spark Plug Specifications	44
Oil Filter Specifications	44
Engine Oil	44
Changing the Engine Oil	44
Inspect and Clean Engine Air Cleaner	46
Spark Plug	46
Battery Maintenance	47
Resetting the Maintenance Hour Meter	47
Corrosion Protection	47
Maintenance After Submersion	47
Troubleshooting HSB	48
Additional Information	50
Surge Protection	50
Customer Familiarization Summary	50
HSB, ATS Model & Serial Reference ATS Back-up Circuits	51
Maintenance and Service Record	52

FOR PARTS BREAKDOWN

Search by model number at
championpowerequipment.com

INTRODUCTION

Congratulations on your purchase of a Champion Power Equipment (CPE) product. CPE designs, builds, and supports all of our products to strict specifications and guidelines. With proper product knowledge, safe use, and regular maintenance, this product should bring years of satisfying service.

Every effort has been made to ensure the accuracy and completeness of the information in this manual at the time of publication, and we reserve the right to change, alter and/or improve the product and this document at any time without prior notice.

CPE highly values how our products are designed, manufactured, operated, and serviced as well as providing safety to the operator and those around the generator. Therefore, it is **IMPORTANT** to review this product manual and other product materials thoroughly and be fully aware and knowledgeable of the assembly, operation, dangers and maintenance of the product before use. Fully familiarize yourself, and make sure others who plan on operating the product fully familiarize themselves too, with the proper safety and operation procedures before each use. Please always exercise common sense and always err on the side of caution when operating the product to ensure no accident, property damage, or injury occurs. We want you to continue to use and be satisfied with your CPE product for years to come.

When contacting CPE about parts and/or service, you will need to supply the complete model and serial numbers of your product. Transcribe the information found on your product's nameplate label to the table below

CPE TECHNICAL SUPPORT TEAM
1-877-338-0999
MODEL NUMBER
201202
SERIAL NUMBER
DATE OF PURCHASE
PURCHASE LOCATION

HOME STANDBY GENERATOR

This home standby generator is intended exclusively for outdoor installation. This generator will operate using either liquified petroleum gas (LPG) or natural gas (NG).

This generator is designed to supply typical home load such as:

Induction motors – sump pumps, refrigerators, air conditioners, furnaces

Electronic items – televisions, computers

Household lighting

Microwaves

This generator is not intended for use in critical life support applications.

Proper sizing of the generator is required to ensure safe operation of appliances. Some appliances require additional wattage to start and must be considered in the sizing of the generator.

SAFETY

Safety Definitions

The purpose of safety symbols is to attract your attention to possible dangers. The safety symbols, and their explanations, deserve your careful attention and understanding. The safety warnings do not by themselves eliminate any danger. The instructions or warnings they give are not substitutes for proper accident prevention measures.

DANGER

DANGER indicates a hazardous situation which, if not avoided, will result in death or serious injury.

WARNING

WARNING indicates a hazardous situation which, if not avoided, could result in death or serious injury.

CAUTION

CAUTION indicates a hazardous situation which, if not avoided, could result in minor or moderate injury.

NOTICE

NOTICE indicates information considered important, but not hazard-related (e.g., messages relating to property damage).

IMPORTANT SAFETY INSTRUCTIONS

⚠ WARNING

Cancer and Reproductive Harm – www.P65Warnings.ca.gov

Carbon Monoxide Hazards

⚠ DANGER

Generator exhaust contains carbon monoxide (CO), a colorless, odorless, poisonous gas. Breathing carbon monoxide (CO) will cause nausea, dizziness, fainting or death. If you start to feel dizzy or weak, get to fresh air immediately.

GENERATOR MUST BE INSTALLED AND OPERATED OUTDOORS ONLY.

Carbon monoxide (CO) poisoning symptoms include but are not limited to the following:

- Lightheadedness, dizziness, blurred vision
- Physical fatigue, weakness in joints and muscles
- Mental fatigue, sleepiness, inability to concentrate or speak clearly,
- Stomachache, vomiting, nausea

In the event of carbon monoxide (CO) poisoning:

- Seek fresh air immediately
- DO NOT sit, lie down or fall asleep.
- Alert others to the possibility of carbon monoxide (CO) poisoning.
- If the affected person does not improve within minutes of breathing fresh air, call 911 immediately for medical assistance.

⚠ DANGER

Carbon Monoxide (CO) is a colorless, odorless, poisonous gas. Breathing carbon monoxide will cause nausea, dizziness, fainting or death.

Generator must be installed and operated outdoors only.

NEVER allow exhaust fumes to enter a confined area through windows, doors, air intake vents or other openings of the building.

ALWAYS avoid breathing exhaust fumes when near an operating generator.

NEVER alter the generator or modify the exhaust system thereby creating noncompliance with Federal and State emissions regulations, local applicable codes, standards and laws.

NEVER allow blockage of the engine's air intake cooling ventilation system. Doing so can seriously affect performance and safe operation of the generator.

⚠ WARNING

Always install a battery-operated Carbon Monoxide (CO) detector on each level of any building or home dwelling adjacent to the generator location following the Carbon Monoxide (CO) detector manufacturer's installation instructions.

In many U.S. States and Canadian Provinces, it is required by law to have a Carbon Monoxide (CO) detector installed on each level of an occupied building or home dwelling.

The Carbon Monoxide (CO) detector is a device that detects elevated levels of poisonous Carbon Monoxide (CO) gas and will alert the occupants by flashing a visual light indicator and an audible alarm.

The Carbon Monoxide (CO) detector alarm will not sense smoke, fire, or any other poisonous gas other than carbon monoxide.

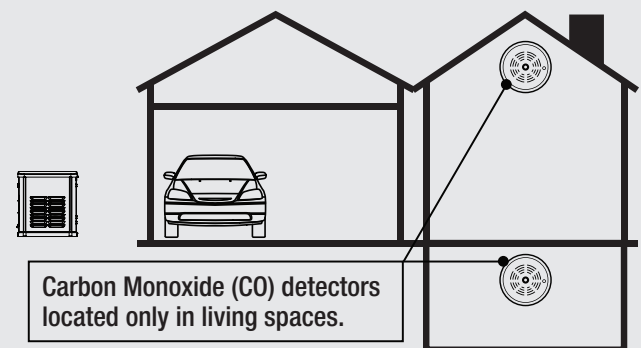

⚠ WARNING

Smoke alarms cannot detect Carbon Monoxide (CO) gas.

To better educate yourself about all carbon monoxide risks, go to www.takeyourgeneratoroutside.com

⚠ WARNING

Do not use generator for medical life support uses.

In case of emergency, call 911 immediately.

NEVER use this product to power life support devices or life support appliances.

Inform your electricity provider immediately if you or anyone in your household depends on electrical equipment to live.

Inform your electrical provider immediately if a loss of power would cause you or anyone in your household to experience a medical emergency.

Installation Hazards**⚠ WARNING**

Always have a qualified electrician or installation technician who are familiar with applicable safety codes, standards and regulations to install and service the generator.

ALWAYS comply with local, state and national electrical and building codes when installing the generator.

NEVER alter the recommended installation in a way that would render the unit non compliant with these codes.

ALWAYS comply with regulations that Occupational Safety and Health Administration (OSHA) has established.

ALWAYS follow the generator manufacturer's instructions.

Before Starting**⚠ WARNING**

Before operation, read and understand the features and controls of the generator, including the safety and maintenance sections of this manual.

The owner/operator is responsible for all periodic maintenance. Complete all scheduled maintenance in a timely manner.

Correct any issue before operating the generator.

The owner/operator is responsible for the safe operation of this generator.

If any portion of this manual is not understood, contact your Champion dealer for assistance before operating the generator.

For service or parts assistance, contact your Champion dealer if repairs are needed.

Operation Hazards**⚠ WARNING**

ALWAYS operate the generator following the manufacturer's instructions. Operating the generator improperly or neglecting maintenance can result in serious injury or possible death.

DO NOT allow children or unqualified persons to operate or service the generator.

NEVER operate the generator with the covers open. Only operate the generator with the covers closed and secured in place.

NEVER leave the generator covers unlocked.

NEVER work on the generator when physically or mentally fatigued. Remain alert at all times when working on the generator.

NEVER operate the generator while under the influence of alcohol or drugs.

NEVER climb or step on any part or components of the generator. Doing so may result in personal injury and cause damage to the exhaust system and/or create leakage to the fuel system.

Accidental Starting

⚠ WARNING

ALWAYS prevent the generator from starting while the covers are open. The generator may crank and start at any time without notice. Follow these steps in order:

1. Pull fuse from flex Controller™ panel and secure with tape to the panel.
2. Disconnect the NEGATIVE, NEG or (-) battery cable first, and then remove the POSITIVE, POS or (+) battery cable.

To return the generator to service, follow these steps in order:

1. Connect the POSITIVE, POS or (+) battery cable first, and then connect the NEGATIVE, NEG or (-) battery cable.
2. Remove taped fuse from the panel and reinstall into the flex Controller™.

Electrical Shock Hazards

⚠ WARNING

The generator produces dangerous voltage. Use extreme caution when near the generator while it is operating.

Avoid contact with bare wires, terminals and connections while the generator is operating.

ALWAYS stand on an insulated dry surface to reduce shock hazard if work must be done on an operating generator.

NEVER wear jewelry that can conduct electricity when working on the generator.

NEVER handle any kind of electrical device while hands or feet are wet, while standing in water or while barefoot.

Proper earth grounding of the frame and external electrical conductive components is required by the National Electrical Code (NEC). State and local codes for proper grounding may also apply.

Avoid direct contact with an electric shock victim. Immediately shut down the source of electrical power. If this is not possible, attempt to free the victim from the live conductor using a nonconducting item such as a dry board or rope. If the victim is unconscious, apply first aid and call 911 immediately.

Fuel Safety

⚠ DANGER

PROPANE AND NATURAL GAS ARE HIGHLY FLAMMABLE AND EXPLOSIVE.

Fire or explosion can cause severe burns or death.

Propane/LPG (liquified petroleum gas) and LPG Vapors:

- LPG is a hydrocarbon gas that exists in a liquified form and it's vapors are highly flammable and explosive.
- LPG and it's vapors are under pressure and can cause a fire or explosion if ignited.
- LPG vapors are heavier than air and will settle in low places while dissipating.
- LPG itself is odorless and tasteless. For safety, a chemical is added to give it an odor to help detect leaks quickly.
- If a leak is detected, IMMEDIATELY turn OFF the gas supply.
- In the event of an LPG fire and only when safe to do so, first close the regulator valve OFF and then use a dry powder extinguisher to put out the fire. This is because if a fire is extinguished before the regulator valve is closed OFF, then an explosion hazard condition could be created.
- Always keep the LPG cylinder in an upright position.
- LPG is a skin irritant and can cause severe cold burns similar to frostbite.
- Always wear proper protective gloves when connecting to and disconnecting from a propane bottle.
- Always keep LPG away from sparks, open flames, pilot lights, heat and other sources of ignition.

⚠ DANGER

NG (natural gas) and NG Vapors:

- NG vapors are highly flammable and explosive.
- NG vapors can cause a fire or explosion if ignited.
- NG itself is odorless and tasteless. For safety, a chemical is added to give it an odor to help detect leaks quickly.
- NG is lighter than air and will collect in higher areas.
- If a leak is detected, IMMEDIATELY turn OFF the gas supply.

⚠ DANGER

NEVER allow any flames or smoke near the fuel system.

Wipe up any oil spills immediately.

NEVER allow any combustible materials to be near the generator or to be left in the generator compartment.

ALWAYS keep the surrounding area near the generator clean and free of debris.

Be sure to properly purge the fuel lines and leak-test according to applicable codes before placing the generator in service.

Be sure to regularly inspect the fuel system for leaks. For safety, a chemical is added to Propane/LPG/NG to give it an odor to help detect leaks quickly. Never operate the generator if a fuel leak is present.

Install a fire extinguisher near the generator. Keep it properly charged and be familiar with its use. An ABC rated National Fire Protection extinguisher is appropriate for use on standby electric systems. Contact your local fire department with any questions concerning the fire extinguisher.

⚠ DANGER

NEVER place a gasoline container, gasoline tank, LPG cylinder or any combustible material in the path of the exhaust stream during operation of the generator.

⚠ WARNING

Never use a remote or external fuel supply tank or flexible fuel hose, or any other fuel component that is broken, cut, torn or damaged.

Burn Hazards**⚠ WARNING**

DO NOT touch hot surfaces.

ALWAYS avoid contact with hot exhaust components and gases. Running engines produce heat. Severe burns can occur on contact.

ALWAYS allow hot surfaces to cool to the touch.

Entanglement Hazards**⚠ WARNING**

Use extreme caution when near rotating parts. Rotating parts can entangle hands, feet, hair, clothing and/or accessories. Traumatic amputation or severe laceration can result.

Keep hands and feet away from rotating parts.

Tie up long hair and remove jewelry.

Operate equipment with guards in place.

DO NOT wear loose-fitting clothing, dangling drawstrings or items that could become caught.

Battery Hazards**⚠ WARNING**

Always read and comply with the battery manufacturer's recommendations for procedures concerning proper battery use and maintenance.



Batteries contain sulfuric acid and generate explosive mixtures of hydrogen and oxygen gases. Keep any device that may cause sparks or flames away from the battery to prevent explosion.





Always wear protective glasses or goggles and protective clothing when working with batteries. Always follow the battery manufacturer's instructions on safety, maintenance and installation procedures.

Safety Symbols

Some of the following symbols may be used on this product. Please study them and learn their meaning. Proper interpretation of these symbols will allow you to more safely operate the product.

SYMBOL	MEANING
	Read Operator's Manual. To reduce the risk of injury, user must read and understand operator's manual before using this product.
	Eye protection. Always wear eye protection with side shields marked to comply with ANSI Z87.1
	Wear personal protective equipment
	Safety alert symbol
	Asphyxiation hazard
	Electrical shock hazard
	Entanglement hazard
	Fire hazard
	Fire/Explosion. Fuel and its vapors are extremely flammable and explosive. Fire or explosion can cause severe burns or death.
	Hot Surface. To reduce the risk of injury or damage, avoid contact with any hot surface.

SYMBOL	MEANING
	Sever hazard (rotating blade)
	Crush hazard (top)
	Explosion Hazard. Battery gases are explosive. Keep sparks and flames away from the battery compartment.





SAFETY LABELS AND HANG TAGS

⚠ WARNING

DO NOT operate the generator if there are missing or badly worn safety labels. Safety labels must be legible to alert personnel of safety hazards.

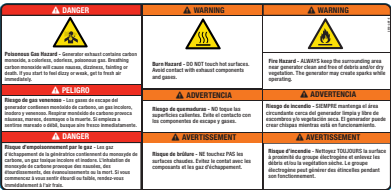
Replace any illegible or missing label immediately. Missing safety labels must be replaced in their original position before the generator is operated.

Labels

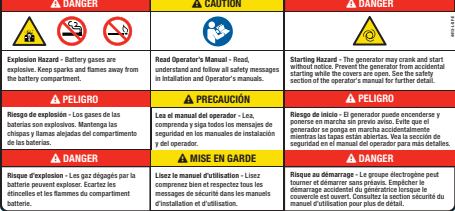
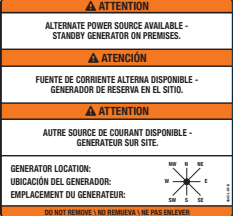
	LABEL	DESCRIPTION	PART NO.
A		Poison, Burn and Fire Warning	2510-L-SF
B		Burn Warning	2483-L-SF
C		Electrocution Warning	4647-L-SF
D		Burn Warning	2473-L-SF
E		Explosion Warning, Read OM, Starting Warning	4413-L-SF
F		Alternate Power Source	4642-L-SF

Hang Tags

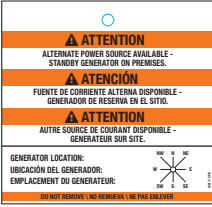
HANG TAG	DESCRIPTION	PART NO.
	<p>Alternate Power Source</p>	<p>1681-T-SF</p>

Safety label and Hang Tag locations

The safety labels have specific placement and must be replaced if they are unreadable, damaged or missing.

If a label comes off or becomes hard to read, contact Technical Support Team for possible replacement.

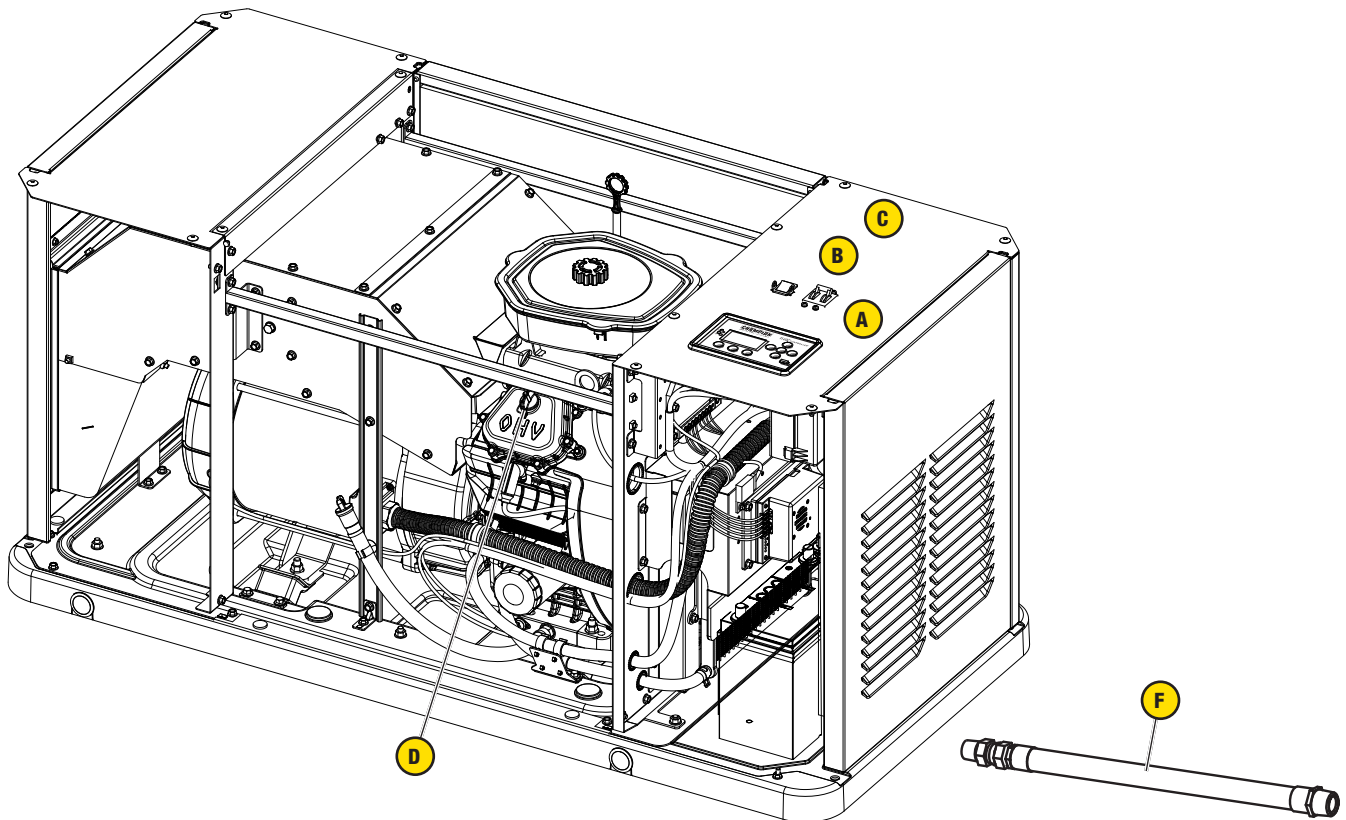

- A. Serial number location
- B. Dataplate
- C. NFPA 37 Compliance

- D. Oil hang tag
- E. Alternate Power Source Hang tag and Label (not shown – in the Operator's Manual bag)
- F. Flexible Fuel Line Hang tag

GENERAL INFORMATION

Component Identification - Home Standby (HSB) Generator

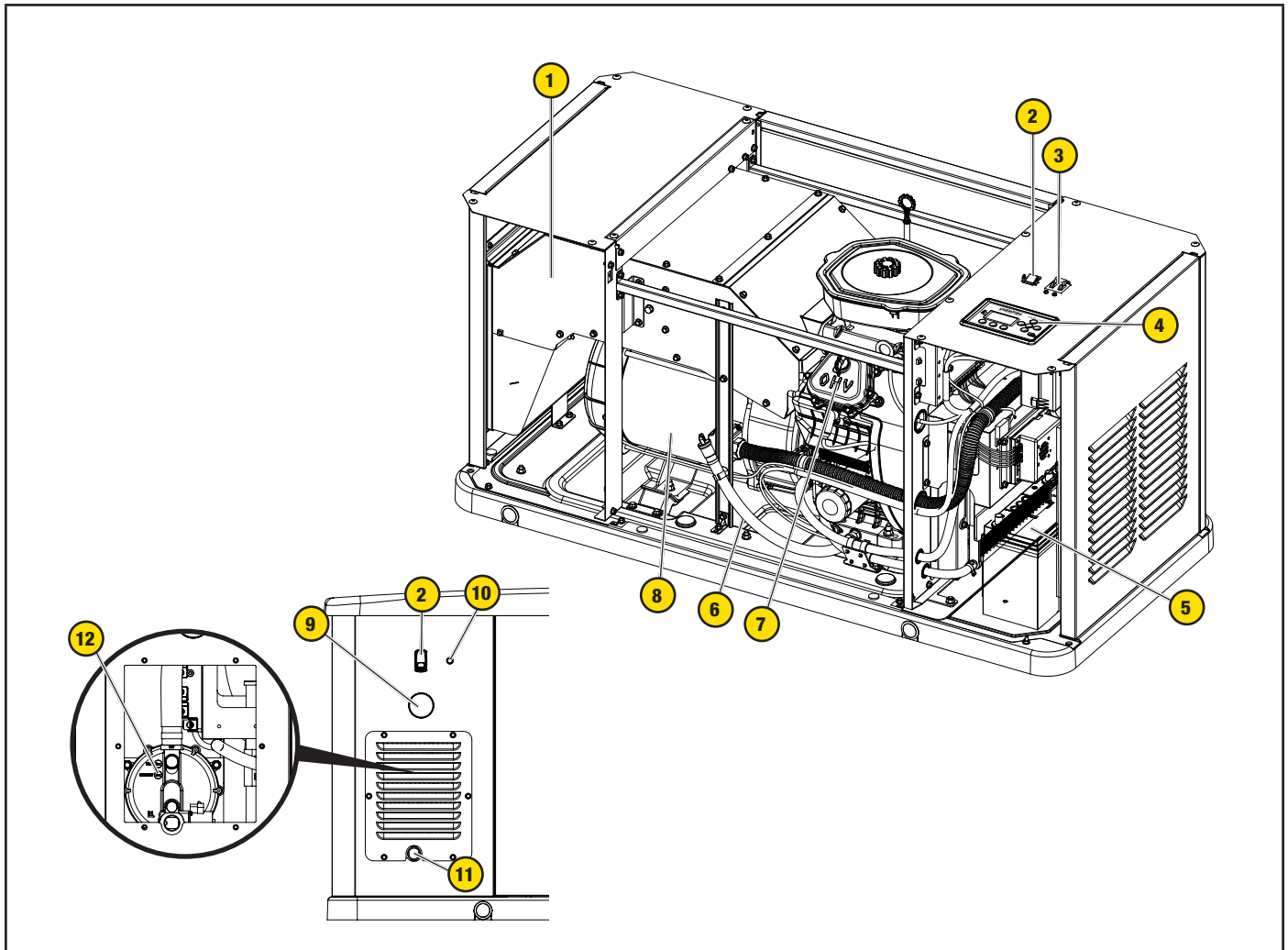

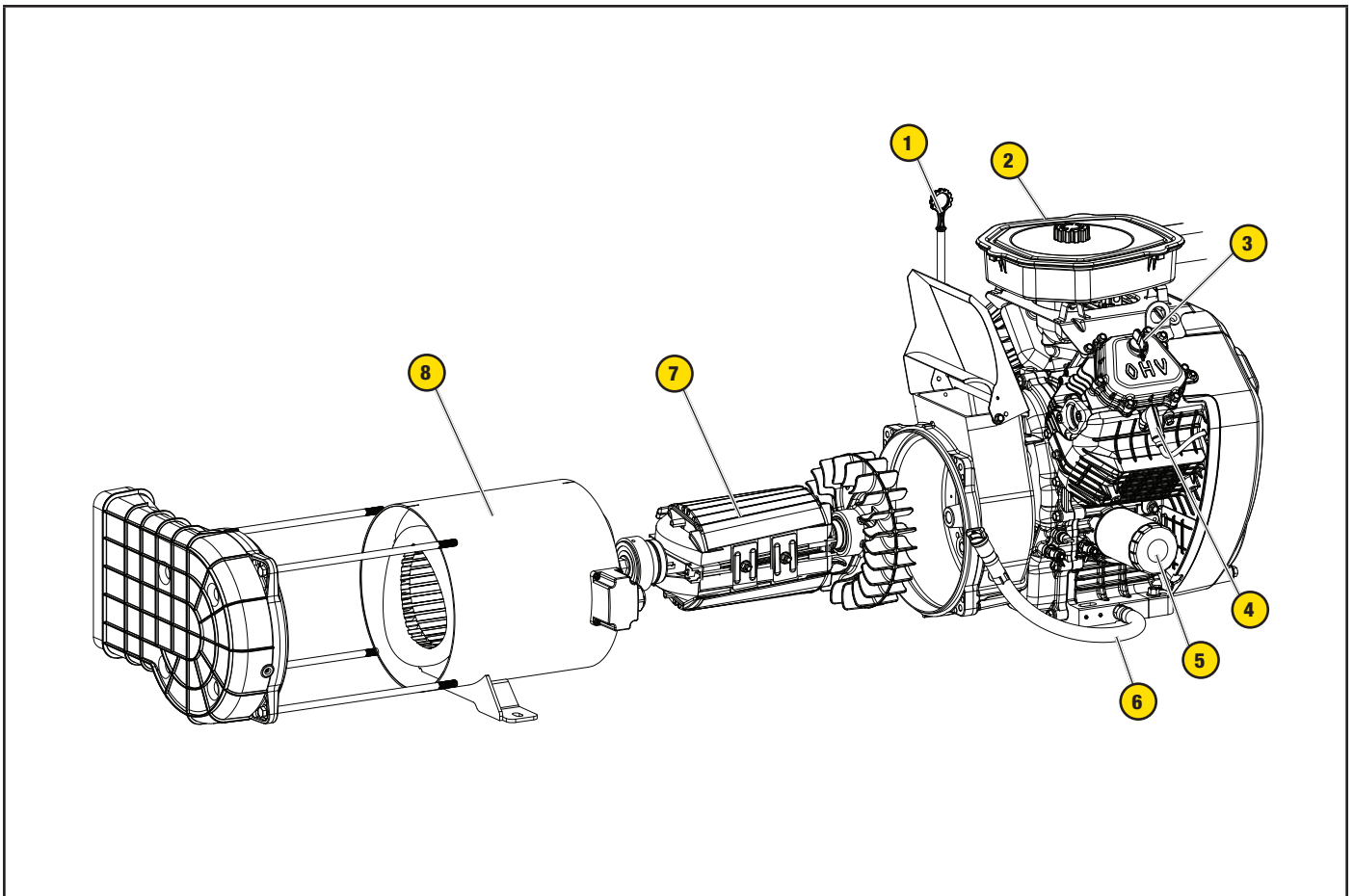

- | | |
|---|--------------------------|
| 1. Exhaust System | 7. Engine |
| 2. Generator ON/OFF | 8. Alternator |
| 3. Main Circuit Breaker | 9. Electric Conduit Caps |
| 4. flex Controller™ | 10. Exterior Warning LED |
| 5. Batteries (not included, side cover) | 11. Fuel Inlet |
| 6. Oil Drain Hose | 12. Fuel Regulator |

Component Identification - Engine

- | | |
|---|-------------------|
| 1. Engine Oil Dipstick | 5. Oil Filter |
| 2. Air Cleaner | 6. Oil Drain Hose |
| 3. Oil Cap | 7. Rotor Assembly |
| 4. Spark Plug (second on opposite side) | 8. Stator |

Operation Symbols

Some of the following symbols may be used on this product. Please study them and learn their meaning. Proper interpretation of these symbols will allow you to more safely operate the product.

SYMBOL	MEANING
	On
	Off
	Ground Terminal

Control Panel

MAIN CIRCUIT BREAKER

The 100-amp main circuit breaker protects the generator from circuit overload. The main circuit breaker controls total output of the generator. The main circuit breaker must be in the ON position for the fleX ATS to communicate with this standby generator.

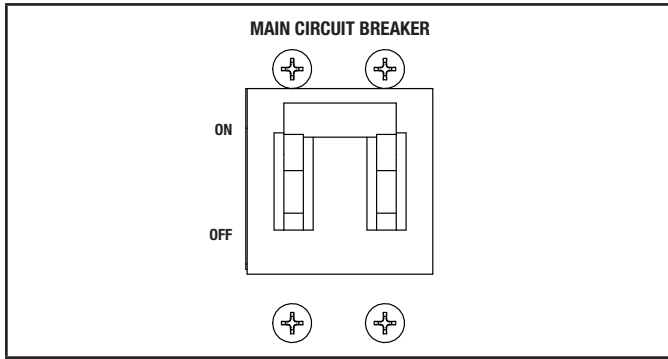

GENERATOR ON/OFF SWITCH

NOTICE

When maintenance or service work is performed on the generator or the home's electrical system, to prevent accidental startup pull out the fuse from the fleX Controller™ panel and disconnect the batteries.

This generator has ON/OFF switches that when turned off, will shut down the HSB (if running) and deactivate the fleX Controller™ preventing future starts. These switches should be used in instances where the HSB needs to stay off regardless of utility power presence. When either switch is in the OFF position, the HSB will not exercise or start for any reason.

When both of the switches are in the ON position, the fleX Controller™ will be energized and the HSB will be controlled by the programming of the fleX Controller™. Both switches need to be in the ON position in order for the HSB to operate in AUTO mode. Put the fleX Controller™ in AUTO mode.

NOTE: Both switches need to be in the ON position to place the fleX Controller™ in the AUTO mode and in order to exercise the HSB.

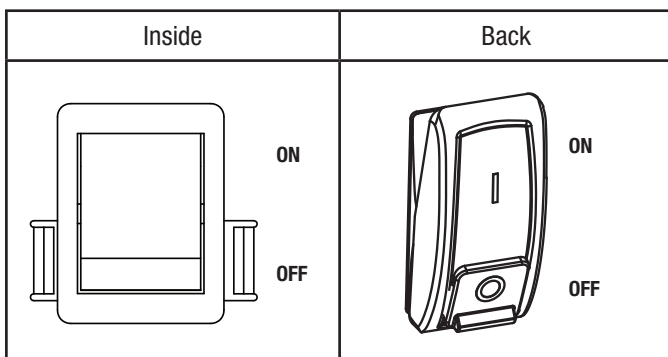

FCC Statement

1. This device complies with Part 15 of the FCC Rules. Operation is subject to the following two conditions:
 - 1a. This device may not cause harmful interference.
 - 1b. This device must accept any interference received, including interference that may cause undesired operation.
2. Changes or modifications not expressly approved by the party responsible for compliance could void the user's authority to operate the equipment.

NOTICE

This equipment has been tested and found to comply with the limits for a Class B digital device, pursuant to Part 15 of the FCC Rules. These limits are designed to provide reasonable protection against harmful interference in a residential installation. This equipment generates, uses and can radiate radio frequency energy and if not installed and used in accordance with the instructions, may cause harmful interference to radio communications.

Industry Canada: CAN ICES-002/NMB-002

This device complies with Industry Canada license - exempt RSS standard(s).

Operation is subject to the following two conditions:

1. This device may not cause interference, and
2. This device must accept any interference, including interference that may cause undesired operation of the device.

Industry Canada: ICES-003/NMB-003

This device complies with Industry Canada license - exempt RSS standard(s).

Operation is subject to the following two conditions:

1. This device may not cause interference, and
2. This device must accept any interference, including interference that may cause undesired operation of the device.

fleX Controller™

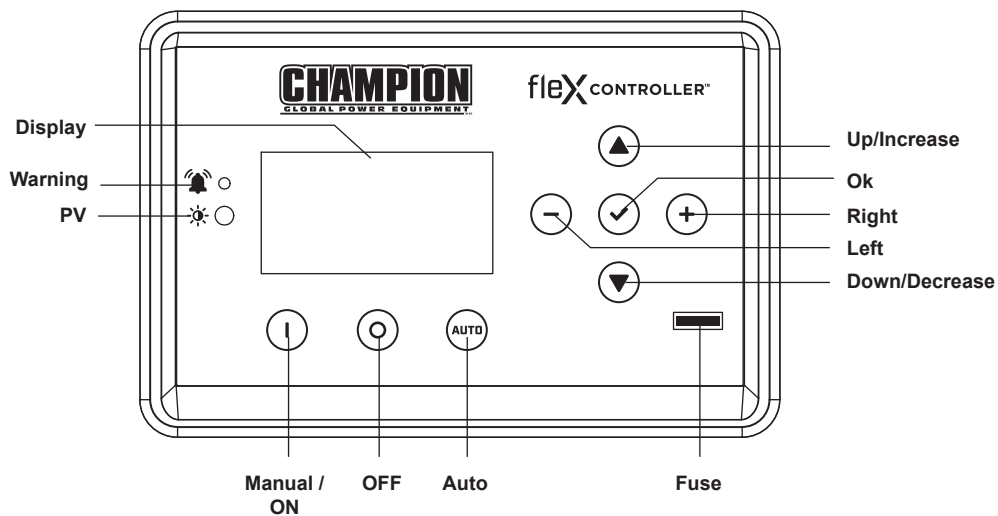

The fleX Controller™ provides real time monitoring, protection, information on the status and settings of the HSB.

Description	
Display	Shows settings and status of the HSB.
Warning	In all cases when the icon is RED, this is an indicator that the HSB has registered a fault and must be corrected. Only the “LOW BATTERY” and “MAINTENANCE” icons will not latch out or shut down the HSB. ALL other RED icon faults will latch out, shut down, disable starting and light the RED icon on the fleX Controller™ and the exterior warning LED on the backside of the HSB.
PV	Photovoltaic (PV) sensor that detects environment light level and adjusts the screen brightness automatically.
Manual/ON	Press to start the HSB in Manual mode. Allows verification that the HSB power delivery circuit is functional. The engine will start in manual mode. Safety procedures should be followed.
OFF	Press to stop the HSB in Manual or Auto mode. Closes and shuts down the engine signals. It prevents the automatic operation of the generator. OFF is required when all maintenance or service is being performed on or around the unit.
Auto	Press to put the HSB in Auto mode. When in Auto, this allows automatic delivery of power from the HSB when there is a utility power outage. With the controller in the Auto and the HSB not running (standby mode), this indicates the household is using utility power. Auto position is the standby ready position. The fleX Controller™ must be in the Auto mode in order to exercise.
Up/Increase	Moves up in the lists of the various settings or increases variables.
Down/Decrease	Moves down in the lists of the various settings or decreases variables.
Right	Moves right in the lists of the various settings.
Left	Moves left in the lists of the various settings.
Ok	Confirms programming the fleX Controller™. Press and hold to enter settings pages.
Fuse	Protects the fleX Controller™ and allow direct removal to keep the controller from engaging. Remove the fuse while all maintenance or service is being performed on or around the unit.

STATE

STATE variables in fleX Controller™. These are view-only, monitor variables.

Highlighted variables show up after the ATS is connected and powered.

TOP MENU	DESCRIPTION	ON SCREEN
STATE	BATTERY VOLTAGE	BATTERY VOLTS
	CURRENT EVENT RUN TIME	EVENT TIME
	GENERATOR TOTAL HOURS	TOTAL RUN TIME
	VERSION	VERSION
	SERIAL NUMBER	S/N
	SYSTEM OUTPUT L1 AMPS	AMPERAGE L1
	SYSTEM OUTPUT L2 AMPS	AMPERAGE L2
	PHASE VOLTAGE (UTILITY, L1-N)	UTILITY L1-N
	PHASE VOLTAGE (UTILITY, L2-N)	UTILITY L2-N
	LINE VOLTAGE (UTILITY, L1-L2)	UTILITY L1-L2
	UTILITY FREQUENCY	UTILITY Hz
	PHASE VOLTAGE (GEN, L1-N)	GENERATOR L1-N
	PHASE VOLTAGE (GEN, L2-N)	GENERATOR L2-N
	LINE VOLTAGE (GEN, L1-L2)	GENERATOR L1-L2
	GENERATOR FREQUENCY	GENERATOR Hz
	LOAD VOLTAGE (LOAD, L1-N)	LOAD L1-N
	LOAD VOLTAGE (LOAD, L2-N)	LOAD L2-N
	LOAD VOLTAGE (LOAD, L1-L2)	LOAD L1-L2
	LOAD POWER (LOAD, L1-N)	LOAD Power L1-N
	LOAD POWER (LOAD, L2-N)	LOAD Power L2-N
	LOAD POWER (LOAD, L1-L2)	LOAD Power L1L2
	LOAD1 POWER	LOAD1 Power
	LOAD2 POWER	LOAD2 Power
	LOAD3 POWER	LOAD3 Power
	LOAD4 POWER	LOAD4 Power
AC1 POWER	AC1 Power	
AC2 POWER	AC2 Power	

User Settings

USER variables in fleX Controller™.

Highlighted variables show up after the ATS is connected and powered. See Programming fleX Controller™ for more information on initial setup. Abbreviations may not match exact as shown on screen for units of measure. Follow the setting defaults for guidance.

For example, 60 seconds, would be shown as 60 sec. or 60s.



TOP MENU	DESCRIPTION	ON SCREEN	DEFAULT
USER SETTINGS	HOURS UNTIL MAINTENANCE IS REQUIRED	NEXT SERVICE	100.0h
	RESET SERVICE	RESET SERVICE	OFF
	ENGINE START DELAY AFTER UTILITY LOSS	BROWNOUT DELAY	30s
	ENGINE COOLING TIME	ENG COOL TIME	60s
	LANGUAGE	LANGUAGE	english
	SCREEN SLEEP TIME	SLEEP DELAY	600s
	SCREEN BRIGHTNESS	BRIGHTNESS	100%
	PLC COMMUNICATION ON/OFF	PLC COMM	ON
	BOND MODE	BOND MODE	OFF
	OVER THE AIR	OTA	
	SYSTEM TIME (year)	SYS year	2023
	SYSTEM TIME (month)	SYS month	12
	SYSTEM TIME (day)	SYS date	31
	SYSTEM TIME (hour)	SYS hour	0
	SYSTEM TIME (minute)	SYS minutes	0
	SYSTEM TIME (second)	SYS second	0
	SYSTEM TIME (week)	SYS week	6
	DAYLIGHT SAVINGS TIME	DST	OFF
	EXERCISE FREQUENCY	EXERCISE FREQ	None
	EXERCISE DAY OF WEEK	EXERCISE DAY	1
	EXERCISE START (hour)	EXER START H	0
EXERCISE START (minute)	EXER START M	0	
EXERCISE RUN TIME	EXERCISE TIME	15min	

TOP MENU	DESCRIPTION	ON SCREEN	DEFAULT
ATS PARAM	ATS WAITING TIME (UTILITY TO GENERATOR TO GENERATOR)	ATS SWITCH T UG	10s
	ATS WAITING TIME (GENERATOR TO UTILITY)	ATS SWITCH T GU	10s
	UTILITY OVER VOLTAGE	UTIL OVER VOLT	258V
	UTILITY UNDER VOLTAGE	UTIL UNDER VOLT	190V
	UTILITY OVER FREQUENCY TIME	UTIL OVER FREQ	66Hz
	UTILITY UNDER FREQUENCY TIME	UTIL UNDER FREQ	56Hz
	UTILITY OVER VOLTAGE TIME	UTIL OVER VOLT T	500ms
	UTILITY UNDER VOLTAGE TIME	UTIL UND VOLT T	10s
	UTILITY OVER FREQUENCY TIME	UTIL O FREQ T	1s
	UTILITY UNDER FREQUENCY TIME	UTIL U FREQ T	10s
	UTILITY LINE VOLTAGE	UTIL LINE VOLT	15V
	GENERATOR OVER VOLTAGE	GEN OVER VOLT	258V
	GENERATOR UNDER VOLTAGE	GEN UND VOLT	190V
	GENERATOR OVER FREQUENCY	GEN OVER FREQ	66Hz
	GENERATOR UNDER FREQUENCY	GEN UNDER FREQ	56Hz
	GENERATOR OVER VOLTAGE TIME	GEN OVER VOLT T	500ms
	GENERATOR UNDER VOLTAGE TIME	GEN UND VOLT T	10s
	GENERATOR OVER FREQ TIME	GEN O FREQ T	1s
	GENERATOR UNDER FREQ TIME	GEN U FREQ T	10s
	GENERATOR LINE VOLTAGE	GEN LINE VOLT	15V

Status Icons

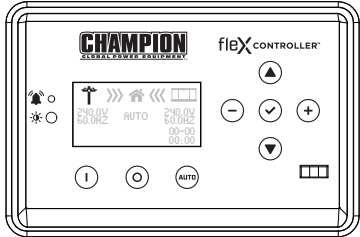
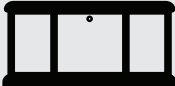
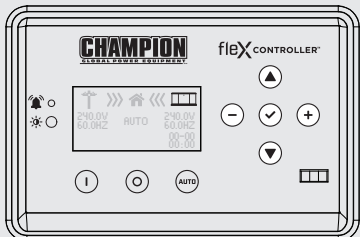

The fleX Controller™ displays status icons.

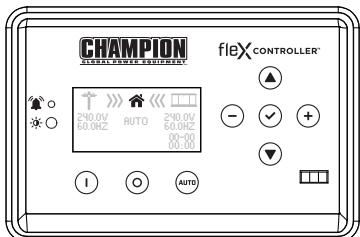
Utility, HSB, House Power

MODE	DESCRIPTION	
<p>Utility</p> 	<p>The utility pole icon indicates utility power.</p>	
<p>HSB</p> 	<p>The HSB icon indicates the generator is running.</p>	
<p>Home</p> 	<p>The home indicates your home is receiving power.</p>	

Transfer Power Direction

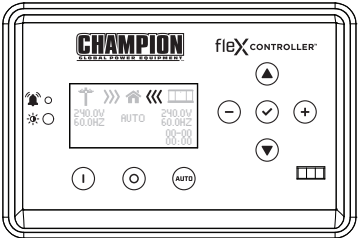
Show the direction of power from HSB or from utility.

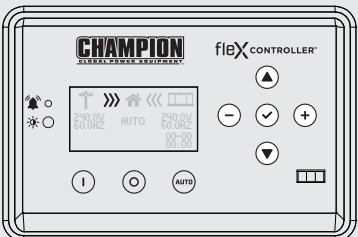
MODE	DESCRIPTION	
<p>HSB Supplying Power</p> 	<p>HSB is supplying power to the home.</p>	
<p>Utility Supplying Power</p> 	<p>Utility is supplying power to the home.</p>	



Information Icons

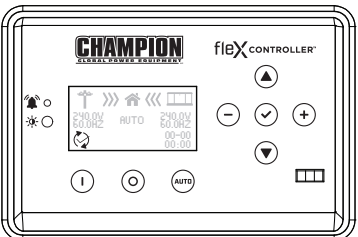

The flex Controller™ displays information icons.



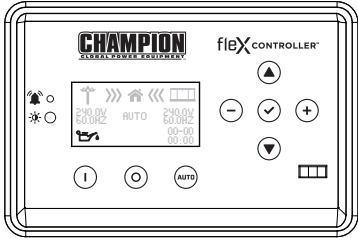

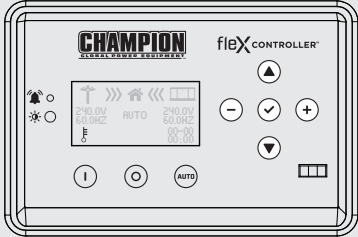

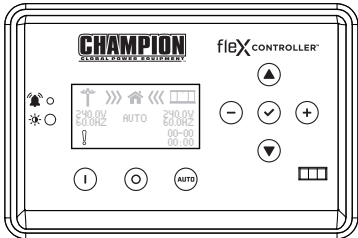
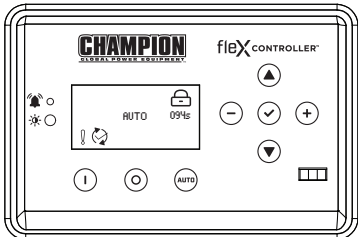
MODE	DESCRIPTION	
<p>Exercise</p> 	<p>The icon indicates when the HSB is performing the exercise period. Refer to “Setting Exercise Time” to establish the weekly exercise period. When the exercise period is complete the icon will turn off and the HSB will resume its standby monitoring. The flex Controller™ must be in the AUTO mode in order to exercise.</p>	

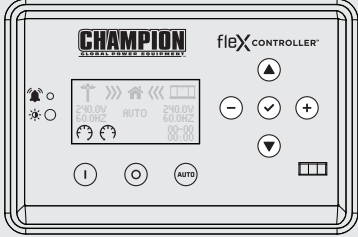

Fault Icons

The fleX Controller™ displays fault icons.

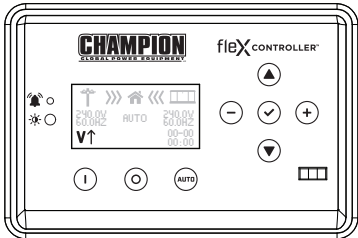
MODE	DESCRIPTION	
<p>Low Oil Pressure Shutdown</p> 	<p>The icon will be lit when the engine oil pressure drops below a safe operating level. When this fault is detected, the HSB will shut down and re-start will be disabled. The warning LED on the controller and exterior will be lit.</p> <p>Check the oil level. The oil level should be at the FULL mark, if necessary, add oil. DO NOT overfill. Inspect the unit for a possible oil leak, if a leak is discovered, contact Champion or your nearest Authorized Champion Dealer. Follow the FAULT CODE RESET instructions to clear the fault after service.</p>	
<p>High Engine Temperature</p> 	<p>The icon will be lit if the engine operating temperature exceeds the factory preset limits. If excessive operating temperature is detected, the HSB will shut down and re-start will be disabled. The warning LED on the controller and exterior will be lit.</p> <p>This failure could be the result of an excessive load or high ambient temperatures. Should this fault occur do the following:</p> <ol style="list-style-type: none"> 1. Open the enclosure doors to increase air flow through the HSB. 2. Check oil level and add oil if required. 3. Inspect the interior and exterior of the enclosure for debris, leaves, etc., and remove them to increase air flow around and inside the unit. 4. Once the engine temperature falls into the normal operating range, generally 30 minutes, follow the FAULT CODE RESET instructions to clear the fault after service. Then, put the fleX Controller™ in AUTO mode. 5. Close the enclosure doors and the unit is ready to run. 	

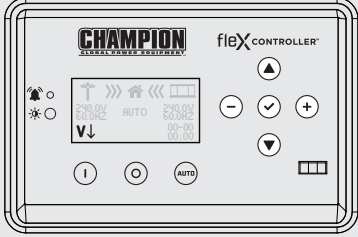
MODE	DESCRIPTION				
	<p>The icon will be lit if the HSB does not start. This prevents the HSB from damaging itself or other related components. When the fault is detected, the HSB will shut down and re-start will be disabled. The warning LED on the controller and exterior will be lit.</p> 				
	<p>STARTER CRANK CYCLE TIMES - If the HSB fails to start, the “OVER CRANK” icon will flash on the fleX Controller™ and a steady lit exterior warning LED on the backside of the HSB. Below outlines the crank cycle differences depending on the mode selected. Please note there is a 120 second lockout or rest period after the cycles for each mode listed to allow the starter to properly cool.</p> <p>Follow the FAULT CODE RESET instructions by pushing the OFF button to reset and clear the fault. Regardless of when you press OFF, you will need to allow the timer to count down to zero (0) before proceeding with another start procedure. The lockout time remaining is shown on the display below the lock icon.</p> 				
	Mode	ON (seconds)	OFF (seconds)	Cycles	Lockout (seconds)
<p>Over Crank</p> 	<p>AUTO The HSB is in the ready position. The fleX Controller™ must be in the AUTO mode in order to exercise.</p>	9	10	5	120
	<p>MAN The HSB will start in MANUAL mode.</p>	10	10	2	120
	<p>EXERCISE / TEST (PLC) The HSB is connected to a Champion Automatic Transfer Switch.</p>	8	30	3	120
	<p>EXERCISE / TEST (2-wire) The HSB is connected to a non-Champion Automatic Transfer Switch.</p>	9	10	5	120
	<p>This failure could also be the result of insufficient fuel supply. Check the in-line fuel shut off valves and make sure they are in the ON/ OPEN position. Position them in the correct position, follow the FAULT CODE RESET instructions to clear the fault after service.</p> <p>If they are in the correct position and the HSB shows a fault light again, it's recommended to perform a Manometer pressure check by an Authorized Champion Dealer or installer. This will make sure the correct amount of fuel is being delivered to the HSB when it starts.</p> <p>Insufficient battery output could result in poor cranking cycles, not permitting the engine starter to reach optimum starting RPM to start the engine. This can be verified by checking the Battery Charger icon, NO CHARGE. If this occurs, the individual battery voltages must be checked to determine if the batteries are properly charged or if they have failed. It is extremely important to follow all the cautions and warnings per the battery manufacturer concerning installation, service, maintenance and replacement procedures.</p>				

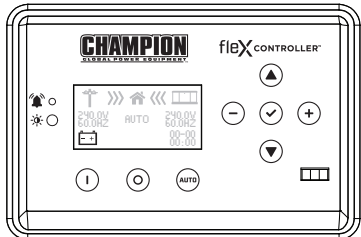
MODE	DESCRIPTION	
<p>Hz Over Speed</p>  <p>Under Speed</p> 	<p>The icon will be lit if the engine was operating above or below its preset speed limits. These limits are factory set to protect the HSB and the circuits connected to the generator output circuits. When this fault occurs, the HSB will shut down, light the warning icon, shut down and re-start will be disabled. The warning LED on the controller and exterior will be lit.</p> <p>When this fault occurs, the HSB will shut down, light the warning icon, shut down and re-start will be disabled. The warning LED on the controller and exterior will be lit.</p> <p>If this failure occurs, contact Champion or your Authorized Champion Dealer. The icon will remain lit until the failure has been corrected, the HSB will not attempt to transfer or run. Follow the FAULT CODE RESET instructions to clear the fault after service.</p>	
<p>Line Over Voltage</p> 	<p>This icon will be lit if the HSB generator output power exceeds preset limits of 258-290 VAC and lasts 0.5 seconds. Alternatively, if the greater than 290 VAC and lasts 0.03 seconds. Both cases occur if running for 6 seconds the condition occurs.</p> <p>When this fault occurs, the HSB will shut down, light the warning icon, shut down and re-start will be disabled. The warning LED on the controller and exterior will be lit. Check and adjust AVR. Set voltage to 240 VAC.</p> <p>If this failure occurs, contact Champion or your Authorized Champion Dealer. The icon will remain lit until the failure has been corrected, the HSB will not attempt to transfer or run. Follow the FAULT CODE RESET instructions to clear the fault after service.</p>	
<p>Line Under Voltage</p> 	<p>This icon will be lit if the HSB generator output power is below preset limits of 216 VAC and lasts 0.5 seconds. This will occur if running for 10 seconds the condition occurs.</p> <p>When this fault occurs, the HSB will shut down, light the warning icon, shut down and re-start will be disabled. The warning LED on the controller and exterior will be lit. Check and adjust AVR. Set voltage to 240 VAC.</p> <p>If this failure occurs, contact Champion or your Authorized Champion Dealer. The icon will remain lit until the failure has been corrected, the HSB will not attempt to transfer or run. Follow the FAULT CODE RESET instructions to clear the fault after service.</p>	

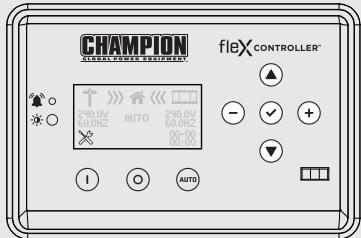
MODE	DESCRIPTION	
<p>Low Battery</p> 	<p>This icon will be lit if the battery voltage falls below 21.0 volts for at least 2 seconds while the engine is running. If the battery voltage rises above 22 volts, the icon will turn off. Battery voltage is NOT monitored when the engine is cranking, just when the engine is running. If the icon comes on it will not shut the HSB off, it will remain lit until the battery condition meets the required output.</p> <p>When this fault occurs, the HSB will not shut down, light the warning icon, the battery charging should be checked. The warning LED on the controller and exterior will be lit.</p> <p>The icon will remain lit until the failure has been corrected, the HSB will continue to transfer or run until voltage drop causes fuel cut solenoid to close. Follow the FAULT CODE RESET instructions to clear the fault after service.</p>	
<p>Maintenance</p> 	<p>This icon will be lit if the HSB requires maintenance.</p> <p>The maintenance hour NEXT SERVICE meter counts from 100 hours to 0. You need to reset when the hour meter reaches 0. Refer to the scheduled maintenance chart.</p> <p>The icon will remain lit until the failure has been corrected, the HSB will continue to transfer or run. Follow the RESET THE MAINTENANCE HOUR METER to clear the fault after service.</p>	

Fault Protection

In all cases when the icon is lit, this is an indicator that the HSB has registered a fault and must be corrected. Only the “LOW BATTERY” and “MAINTENANCE” icons will not latch out or shut down the HSB. ALL other icon faults will latch out, shut down, disable starting and light the icon on the fleX Controller™ and the exterior warning LED on the backside of the HSB.

Fault Code Reset

DESCRIPTION	
1	In the event a fault has occurred
2	Push OFF button to reset
3	Then AUTO

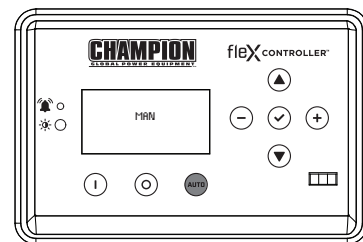
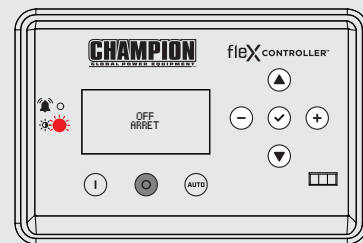
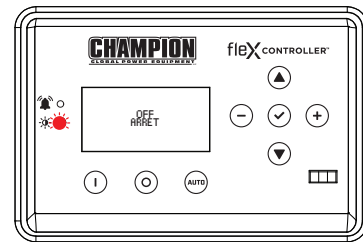

⚠ WARNING

All faults should be taken seriously and corrected before reset process is performed.

Wi-Fi Setup Method

1. Use a Wi-Fi enabled device (laptop, smart phone, tablet, etc.) in near proximity to the ATS.
2. Search and connect to network name (SSID) “Champion ####” where #### will match the last four digits of the serial number that is printed on the control board.

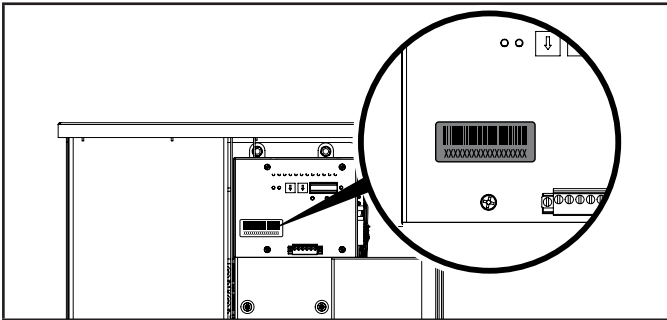

2a. The password for the network is located on a label on the dead front of the ATS.

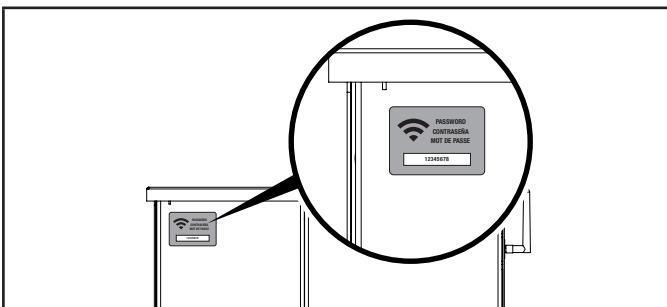

NOTICE

During the setup your device will disconnect from the internet. The Champion Wi-Fi is a direct connection between your device (laptop, smart phone, tablet, etc.) and the ATS, and it does not connect to the internet. Some Android devices may show the following screen – Choose “Connect only this time.”



Internet may not be available.

If you want to connect this network without internet access, you can connect only this time or you can set your phone to always connect to it even if internet isn't available.

You can change this in Settings > Connections > Wi-fi > ADVANCED > Switch to mobile data > Network exceptions

Connect only this time

Allow switch

Stay connected

3. After connecting Wi-Fi, open your device’s web browser. In the browser address change the address to 192.168.0.90 and begin search. This will direct your browser to the Champion flex Controller™ Home Standby Generator Settings page located on the ATS. If your device’s web browser does not load the Champion flex Controller™ Home Standby Generator Settings Page but rather stays connected to the internet, turn off mobile data on the device (if applicable) and make sure the device is not connected to any other networks.

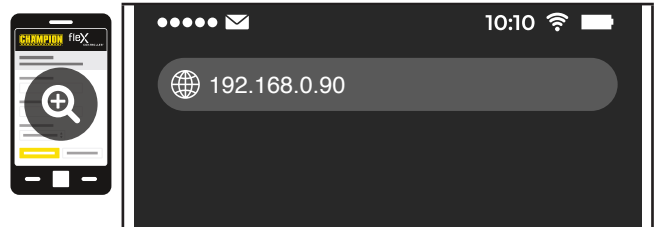

4. On the Champion flex Controller™ Home Standby Generator Settings Page, set the date and time. Use either the dropdown boxes or the “USE THIS DEVICE DATE & TIME” button to set the time and date.



USE DEVICE DATE & TIME

Date: Choose Month... Choose Date... Choose Year...

Time: Choose Hour... Choose Minute... Choose AM/PM...

CONFIRM DATE & TIME

- 5. Confirm and apply the settings before continuing. If you do not apply immediately, the clock will be later than actual. Unsaved changes are highlighted.



Date	March 22, 2022 <i>Unsaved Changes</i>
Time	08:40 AM <i>Unsaved Changes</i>
Day Light Saving	On <i>Unsaved Changes</i>

EDIT DATE & TIME ✎

Generator Exercise

(Automated Maintenance Running)

Frequency:	Every Week
Day:	Friday
Time:	09:00 AM

EDIT EXERCISE FREQUENCY ⬆

✓ APPLY **✗ REVERT**

- 6. Some operating systems will require additional steps to confirm update, accept all pop-up windows until progress bar is seen on screen.



Time 08:40 AM

Are you sure to save the changes?

Cancel **OK**



Saving...



- 7. Set the HSB exercise frequency and schedule.

NOTE: Exercise duration is system set at 15 minutes. The duration is not adjustable. The flex Controller™ must be in the AUTO mode in order to exercise.



Generator Exercise

(Automated Maintenance Running)

Freq:	Choose Mode... ▾
Day:	Choose Day... ▾
Time:	Choose Hour... ▾ Choose Minute... ▾ Choose AM/PM... ▾

CONFIRM EXERCISE FREQUENCY ➤

- 8. Confirm and apply the settings before continuing. Unsaved changes are highlighted.



Generator Exercise

(Automated Maintenance Running)

Frequency	Every Week <i>Unsaved Changes</i>
Day	Thursday <i>Unsaved Changes</i>
Time	01:00 PM <i>Unsaved Changes</i>

EDIT EXERCISE FREQUENCY ✎

✓ APPLY **✗ REVERT**



Are you sure to save the changes?

Cancel **OK**

EDIT EXERCISE FREQUENCY ✎

9. Wireless network settings are not used at this time. The default values (shown below) should not be adjusted. Adjustment of this factory settings will require a certified electrician to correct.



Wireless Network

Internet Service:

Web Page Mode:

AP Mode IP : 192. 168. 0. 90

CONFIRM NETWORK SETTINGS 

CANCEL SETTINGS

10. The time, date, and exercise information have now been setup for the fleX ATS and HSB. You can close your browser and disconnect from the ATS Wi-Fi, or skip to step 2 in the next section “ATS and HSB STATUS USING WIFI”.

ATS and HSB Status Using WIFI

1. Using a WIFI enabled device, connect to the “Champion HSB” WIFI network following steps 1, 2, and 3 from WIFI Setup Method.
2. After loading the Home Standby Generator Settings page, locate and click the  icon at the bottom right corner of the page.
3. You are now viewing the ATS and HSB status page. Items such as voltage, frequency, current, etc. can all be viewed for both utility and HSB power. All of the information is live. There are three tabs located at the top of the page. ATS, GEN, and LMM. Each tab will display the status for the Transfer Switch, Home Standby Generator, or Load Management Module(s) respectively.
4. When finished viewing the status of the ATS, Generator, and LMM, close your browser and disconnect from the WIFI.

Programming fleX Controller™

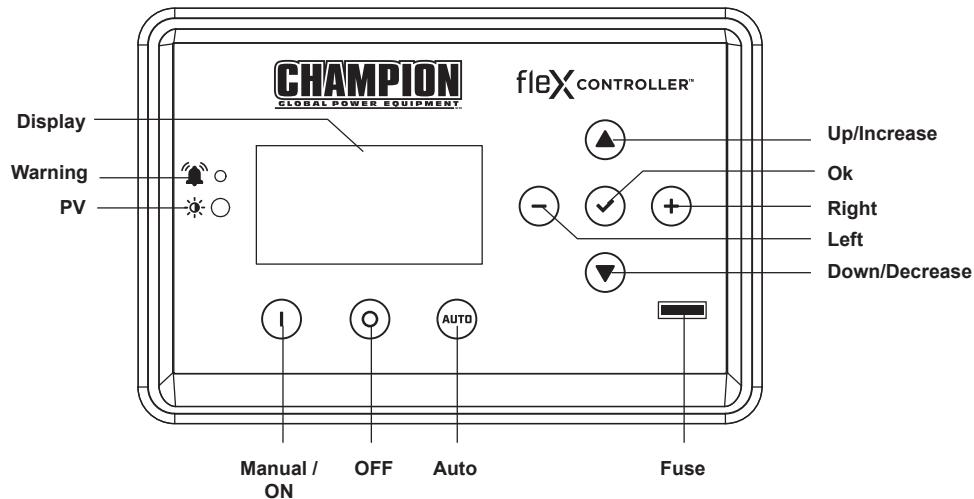

Explanation of USER SETTINGS for setting system and exercise time.

These variables show up after the ATS is connected and powered.

ON SCREEN		DESCRIPTION	DEFAULT VALUE	
1	Year	SYS year	Year – each digit can be adjusted (example 2023 would be 2023)	2023
2	Month	SYS month	January to December with 01-12	12
3	Date	SYS date	Day from 1 to 31	31
4	Hour	SYS hour	Hours in military time 0 - 23	0
5	Minutes	SYS minutes	Minutes from 0-59	0
6	Second	SYS second	Second from 0-59	0
7	Week	SYS week	Week day from 1 to 7 1= Monday 2= Tuesday 3= Wednesday 4= Thursday 5= Friday 6= Saturday 7= Sunday	6
8	Daylight Saving Time	DST	DST on “ON” or “OFF”	OFF
9	Exercise Frequency	EXERCISE FREQ.	Exercise frequency options include: None = no exercise 1x/MO = 1 time per month (12 times annually) 2x/MO = 2 times per month (24 times annually) 4x/MO = 4 times per month (48 times annually) 1x/WK = weekly (52 times annually)	None

ON SCREEN		DESCRIPTION	DEFAULT VALUE
10	Exercise Day	EXERCISE DAY Choose exercise day from 1 to 7 1= Monday 2= Tuesday 3= Wednesday 4= Thursday 5= Friday 6= Saturday 7= Sunday	1
11	Exercise Start Hour	EXER START H Hours in military time 0 - 23	0
12	Exercise Start Minutes	EXER START M Minutes from 0-59	0
13	Exercise Time Duration	EXERCISE TIME Exercise duration from 1-100 minutes	15min

Setting System Time

1. To begin programming, disable AUTO by pressing OFF. The screen should show OFF, then press and hold OK (checkmark icon) for 3 seconds.

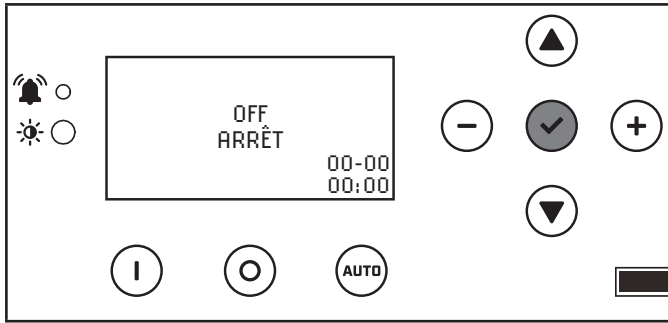

2. Click + until you reach USER SETTINGS. Click down once until the first menu item is highlighted.

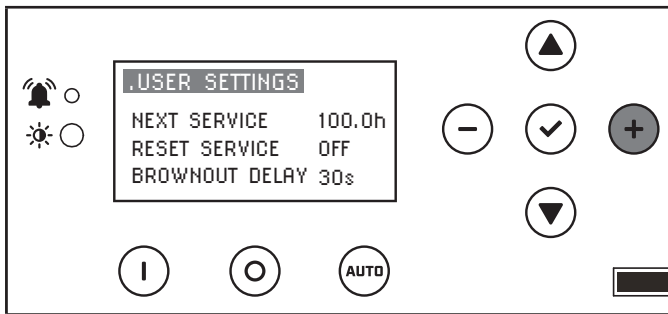

3. Scroll down until you reach date settings. Press OK, on the first setting to adjust year, then month – SYS year and SYS month. Then use a combination of up/down to adjust each digit of the year, then - /+ to move to the right or left and adjust the next digit. Press OK to return and scroll down to adjust month – SYS month - the same way.

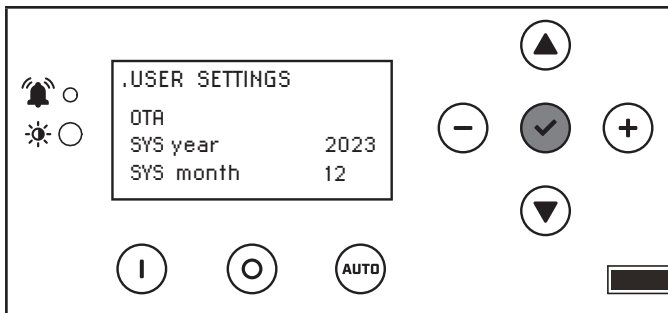

4. Scroll down until you reach date settings. Press OK, on the next setting to adjust date, hour, and minutes – SYS date, hour, minutes. Then use a combination of up/down to adjust each digit on the date, hour, minutes. Then - /+ to move to the right or left and adjust each digit. Press OK to return and scroll down to adjust second, week and DST the same way.

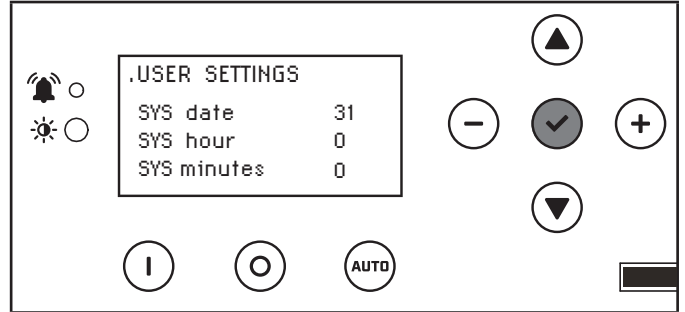

5. Scroll down until you reach date settings. Press OK, on the next setting to adjust second, week, and daylight saving time – SYS second, SYS week, DSI. Then use a combination of up/down to adjust each digit on the adjust second, week, and daylight saving time. Then - /+ to move to the right or left and adjust each digit. DST is just ON or OFF. Press OK to return and scroll down to adjust exercise information.

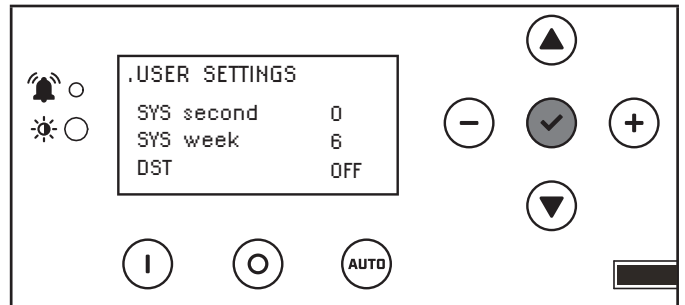

Setting Exercise Time

1. Scroll down until you reach exercise settings. Press OK, on the next setting to adjust exercise frequency, day and start time. Then use a combination of up/down to adjust each digit, then - /+ to move to the right or left and adjust each digit. Press OK to return and scroll down to adjust hour, minutes the same way.

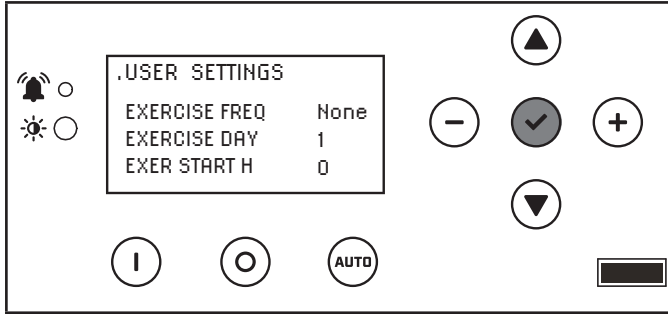

2. Scroll down until you reach exercise settings. Press OK, on the next setting to adjust exercise start time (the minutes portion of the time) and length of exercise (how long the exercise should run in minutes). Then use a combination of up/down to adjust each digit on the adjust each digit. Then - /+ to move to the right or left and adjust each digit. Press OK to return.

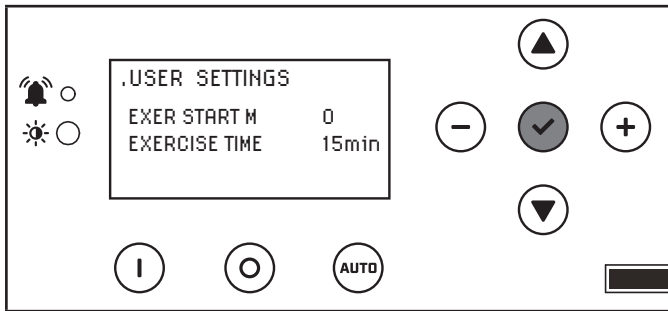

Setting Brownout Delay

Brownout allows you to adjust the settings of the flex Controller™ to delay start up of the HSB during a brownout or partial, temporary reduction in system voltage or total system capacity from your utility. Default is 30 seconds. Choose in second increments (0-600 seconds).

1. To begin programming, disable AUTO by pressing OFF. Then press and hold OK for 3 seconds.

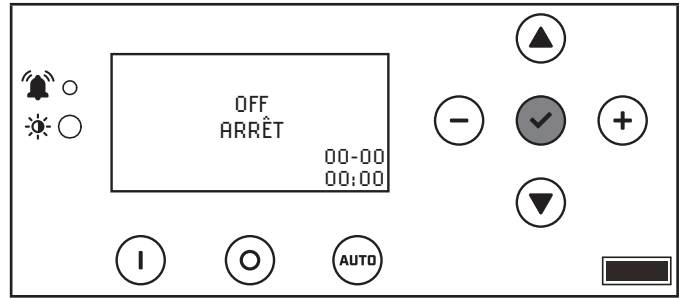

2. Click + until you reach USER SETTINGS. Click down once until the first menu item is highlighted.

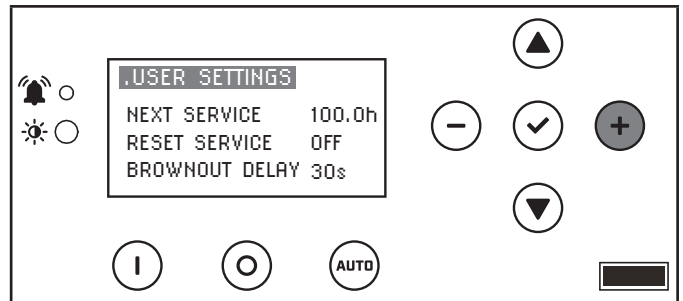

3. Scroll down until you reach BROWNOUT DELAY, and press OK.

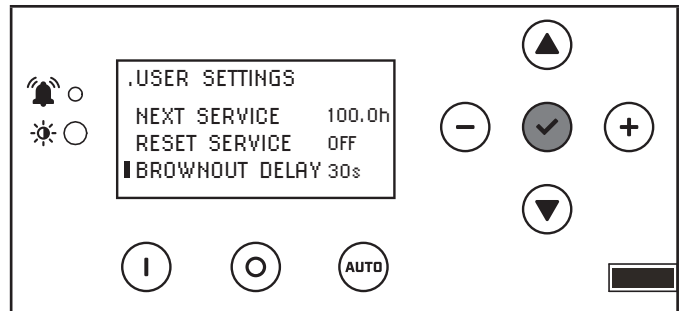

4. Use a combination of up/down to adjust. Then -/+ to move to right or left each digit brown out delay. Default is 30 seconds. Choose in second increments (0-600 seconds). Press OK to return.

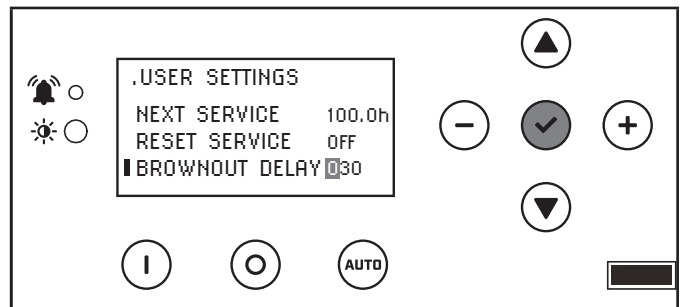

Setting Power Line Carrier (PLC)

PLC Communication (PLC COMM) allows you to adjust the settings of the flex Controller™ to turn off communication if you setup two-wire start or do not have utility. Default is ON.

1. To begin programming, disable AUTO by pressing OFF. The screen should show OFF. Then press and hold OK for 3 seconds.

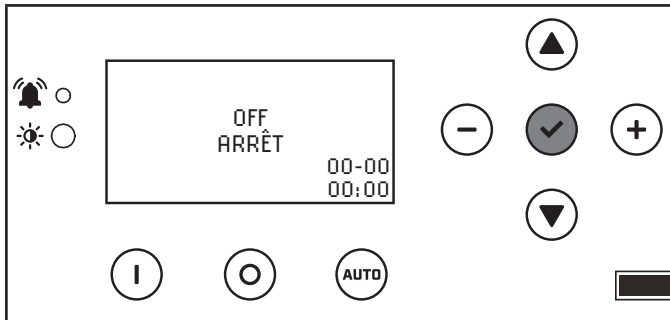

2. Click + until you reach USER SETTINGS. Click down once until the first menu item is highlighted.

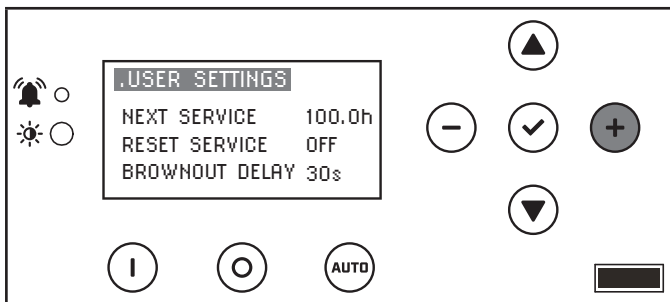

3. Scroll down until you reach PLC COMM, and press OK.

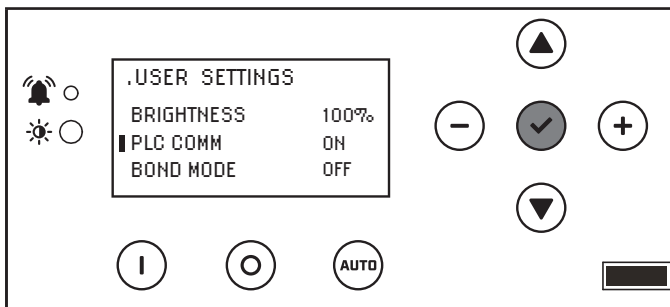

4. Use a combination of up/down to adjust. Default is ON. Press OK to return.

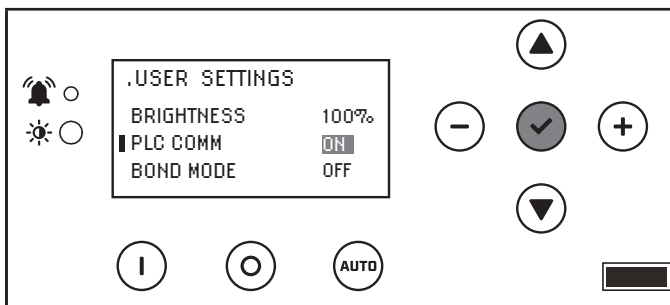

Battery Charger

The LEDs on the battery charger indicate whether the charger has 120VAC power, if there is a battery fault and the charger state. Battery charger rating 24 VDC 7 A.

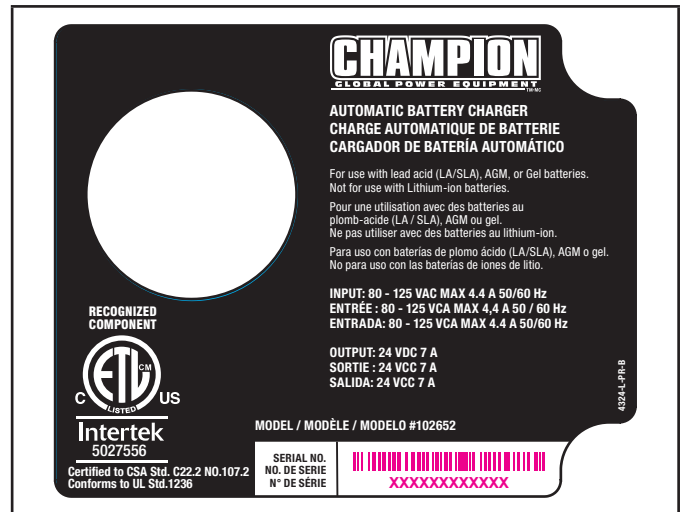

LED	SYMBOL	DESCRIPTION
		DC Voltage Adjustment - Preset from the factory for proper DC charger output. No adjustments necessary.
	E. O.	Enforced Output - Press to charge battery at maximum amperage for a short period.
	Green	Power - Lit to indicate the charger is receiving 120 VAC and is ready to charge.
	Red	Fault or No Charge - Lit to indicate a battery charging problem. If this LED is lit, the LED on the flex Controller™, "LOW BATTERY" will also be lit.
	Yellow	High Charge - Lit to indicate the charger is operating above 50% capacity. Trickle charge and mid charge LED will also be lit.
	Yellow	Mid Charge - Lit to indicate the charger is near 50% capacity. Trickle charge LED will also be lit.
	Yellow	Trickle Charge - Lit to indicate the battery is receiving a trickle charge.
No Yellow		Low Trickle Charge - When no yellow LEDs are lit, the charger is in low trickle charge state.

Emission Requirements

This engine-powered generator meets all United States Environmental Protection Agency (EPA) Phase 3 requirements and is approved for use in both the USA and Canada.

This generator is certified to operate on pipeline NG and LPG (vapor) fuel for use as a stationary engine for standby power generation. Federal and/or local laws may be violated if it is used for any other purpose.

The maintenance schedule must be followed to ensure that the engine complies with the applicable emission standards for the duration of the engine's life.

NOTICE

For Emission control devices and systems, read and understand your responsibilities for service as stated in the Emission Control Warranty Statement of this manual.

Specifications

Home Standby Generator	
Maximum continuous power, LPG	22 kW
Maximum continuous power, NG	19.8 kW
Rated voltage	120/240
Amps	183.4/91.7 LPG (propane), 165/82.5 NG (natural gas)
Harmonic distortion	Less than 5%
Main line circuit breaker	100 amp
Phase	Single
Frequency	60 Hz
Unit weight	557.9 lbs. (253 kg) (no battery)
Size (L x W x H)	56.3 x 28 x 28.5 in. (143 x 71 x 72.5 cm)
Engine	
Type	OHV Commercial V-Twin
No. of cylinders	2
Displacement	999 cc
Cylinder block	Aluminum with cast iron sleeves
Ignition system	TCI (Transistorised Coil Ignition)
Spark plug	Champion RC12YC(NGK-BKR7ES-11)
Governor	Electronic
Starter	Electric 24V DC
Oil capacity- Dry	3.4 US qt (3.2 L)
Oil capacity- With oil filter change	2.5 US qt (2.4 L)
Oil Type	0W-40 Full Synthetic*
RPM	3600
Controls	
Mode switch auto	Auto start on utility failure
Mode switch manual	Starts on demand
Mode switch off	Stops unit/control and charger active
Ready to run/maintenance messages	Standard
Programmable start delay	Standard
Engine start sequence	Standard
Starter lockout	Standard
Battery charger/low battery indicator	Standard
Charger fault	Standard
AVR over voltage protection	Standard
Low oil protection	Standard
Safety fused	Standard
Overcrank/overspeed/underspeed protection	Standard

*After 25 hours, change oil per maintenance schedule. The recommended oil type for typical use is 0W-40 full synthetic oil. However, using the listed conventional oils shown in the "Recommended Engine Oil Type" chart may be used for typical use. If running generator in extreme temperatures, refer to the "Recommended Engine Oil Type" chart.

Fuel System

The engine is fitted with a dual master mixer assembly carburation system, which allows it to run on either NG or LPG. It has been configured at the factory to run on NG. If your installation requires the engine to run on LPG, orifices in the master mixer assembly carburetor must be changed.

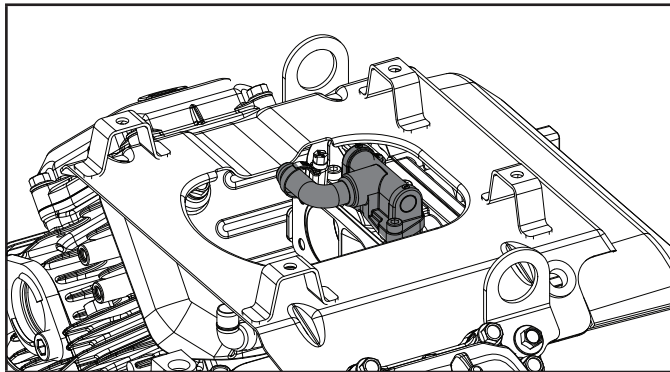

Battery Requirements

Install two (2) 12 volt Group 51 batteries with maximum overall dimension of 9 3/8 x 5 1/16 x 8 3/4 in. (238 x 129 x 223 mm) L x W x H with an Automotive (A) post or terminal configuration. Purchase batteries locally.

The required battery type for typical use is 500 CCA (Cold Cranking Amps). However, a 435 CCA battery shown in the *Recommended Battery Type* chart may be used for typical use, if in a regularly warmer climates.

Alternatively, you may also use two (2) 12 volt Group 51R, but both batteries must be 51R.

Recommended Battery Type					
	← 500 CCA min →				
	← 435 CCA min →				
°F	-40	-4	32	68	104+
°C	-40	-20	0	20	40+
Ambient temperature					

Install positive cable first. Install a battery series cable from the positive (+) terminal of one battery to the negative (-) terminal of the other battery. Always connect the positive (+) battery cable to the generator first.

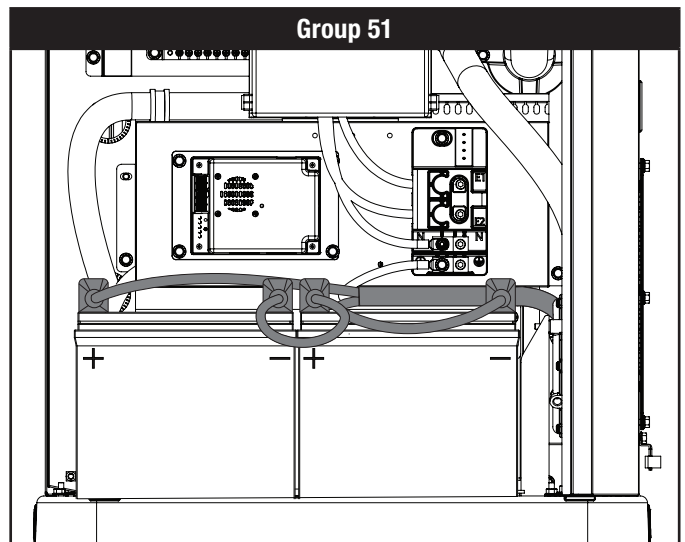
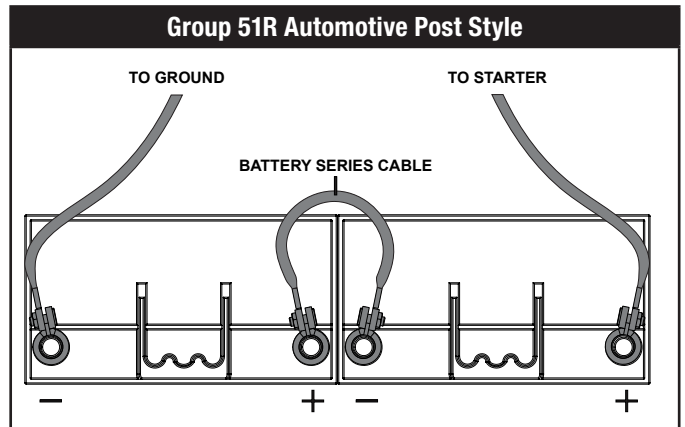
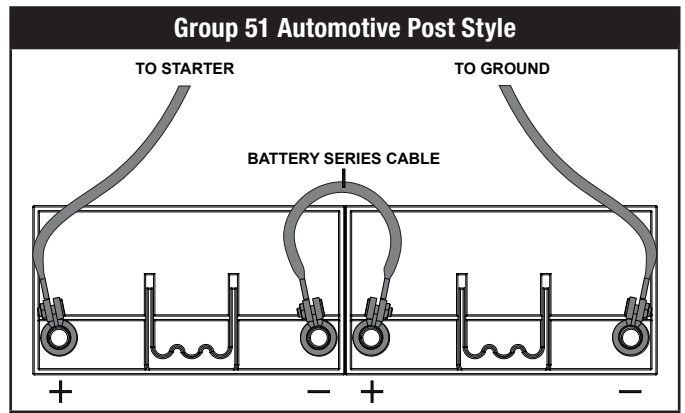

Group 51R

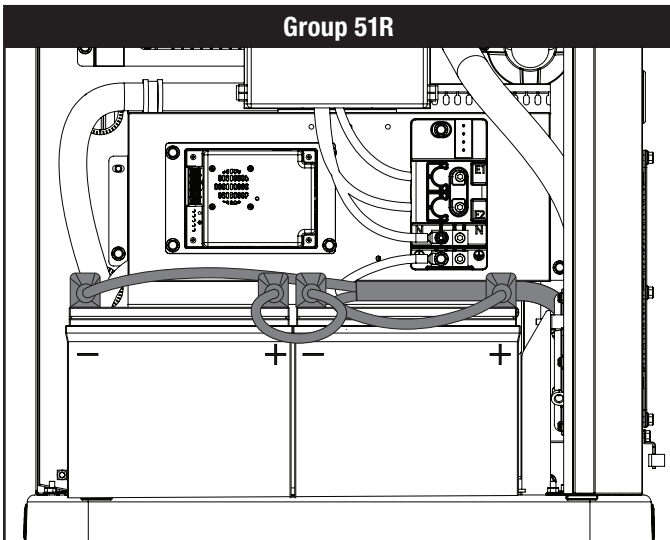

⚠ CAUTION

For battery installation, maintenance, and safety requirements refer to battery manufacturer’s battery installation and safety manual.

Battery Charging

The generator is equipped with an automatic battery charger. The charger will sense the battery’s state of charge and automatically charge the battery when required. LED lights on the charger display the battery state of charge.

Group 51

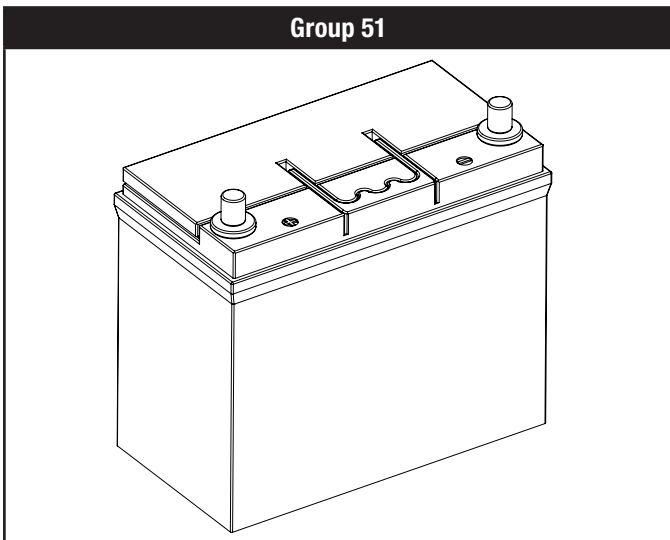

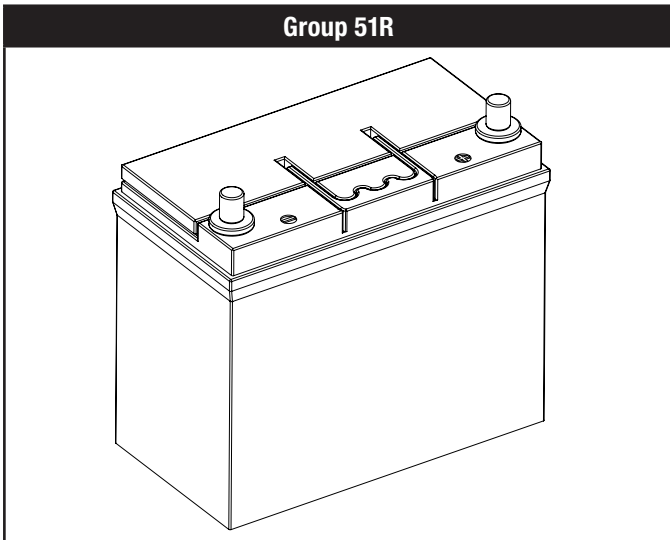

Group 51R



Model and Serial Number

The model and serial number plate is affixed to the generator above the control panel. Have this information if calling for service or ordering parts.

MODEL	201202
RATED VOLTAGE - single phase	TENSION NOMINALE - monophasées
RATED FREQUENCY	FREQUENCE NOMINALE
RATED CURRENT	COURANT NOMINALE
POWER FACTOR	FACTEUR DE PUISSANCE
MAX LOAD UNBALANCE	MAX DÉSÉQUILIBRE DE CHARGE
RATED ENGINE SPEED	RÉGIME MOTEUR NOMINAL
RATED AMBIENT TEMPERATURE	TEMPÉRATURE AMBIANTE NOMINALE
INSULATION CLASS	ISOLATION DE CLASSE
NEUTRAL	NEUTRE
SUBTRANSIENT IMPEDANCE	IMPÉDANCE SUBTRANSITOIRE
TRANSIENT IMPEDANCE	IMPÉDANCE TRANSITOIRE
SYNCHRONOUS IMPEDANCE	IMPÉDANCE SYNCHRONE
FOR STANDBY SERVICE	POUR LE SERVICE DE SECOURS
RAINPROOF ENCLOSURE FITTED	BOTIER ÉTANCHE À LA PLUIE ÉQUIPÉ

Intertek
CONFORME TO
ANSI / CAN / UL / IULC 2200

6370 S PIONEER WAY, UNIT 101, LAS VEGAS, NV 89113 USA / E.U.
1-877-338-0999 • WWW.CHAMPIONPOWEREQUIPMENT.COM

CHAMPION POWER EQUIPMENT, INC.

4423-L-PR-A

OPERATION

Before operating the generator, review **SAFETY** section on page 5 in the operator's manual.

High Altitude

The density of air at high altitudes is lower than at sea level. Power derates at an elevation over sea level and ambient temperatures over 77 °F (25 °C) are:

General power derate is 1% for every 10 °F above 77 °F. (1% for every 5.6 °C above 25 °C).

Elevation derate is 3.5% for every 1,000 feet (304.8 m) above sea level.

No jet change is required for LPG and NG at high elevations. The zero-pressure regulator is self-compensating since it is balanced to atmospheric pressure.

Enclosure and Access

Top Cover

Open the enclosure to gain access to the generator and its components.

- **Top Cover Unlock:** There is a lock under the top cover front to gain access. Insert the provided key, unlock the cover and lift upwards.

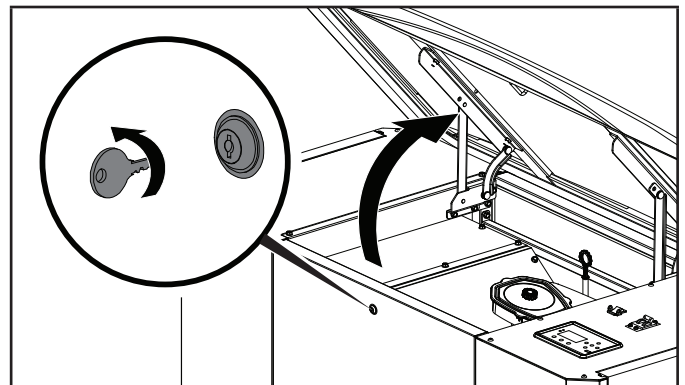

- **Top Cover Lock:** Close the top cover, insert the provided key, turn until the cover locks.

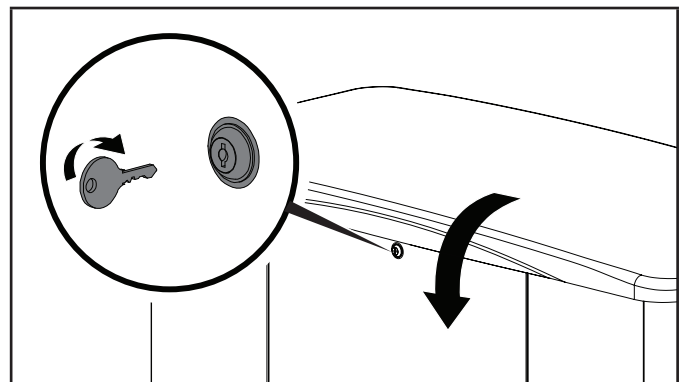

Front Panel

Open the enclosure to gain access to the generator and its components. There is a lock under the top cover front to gain access shown earlier.

- **Front Panel Removal:** Open the top cover and remove the front panel. This front panel is held position with 2 spring loaded pins on the inside. Press inward on each side. Tilt back from the top and lift from the base.

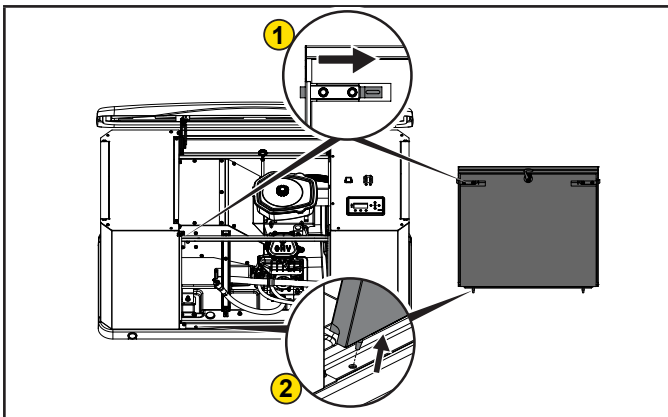

- **Front Panel Replacement:** Replace the front panel by locating the panel pins into the base, tilt the cover forward, then press inward on each side pin. The pins are located on the top, backside of the front panel. Lower top cover and lock.

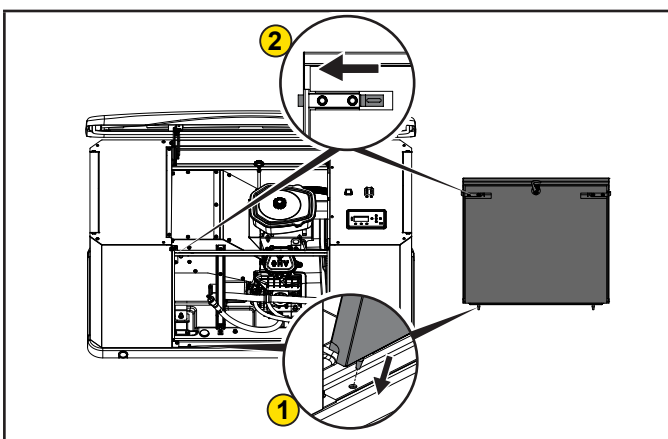

⚠ CAUTION

Do not close panel before moving pins inward, enclosure damage could occur.

Side Panels

Open the enclosure to gain access to the generator and its components. There is a lock under the top cover front to gain access shown earlier. Left panel access muffler side, Right panel access battery, charger, and other connections.

- **Left Panel Removal:** With top cover open, lift up and out each side panel.

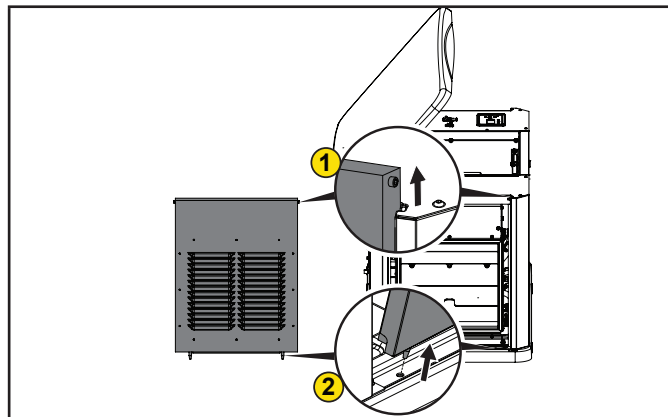

- **Left Panel Replacement:** With top cover open, replace the side panel by locating the panel pins into the base, tilt the cover forward, then slide down with top pins in place. Lower top cover and lock.

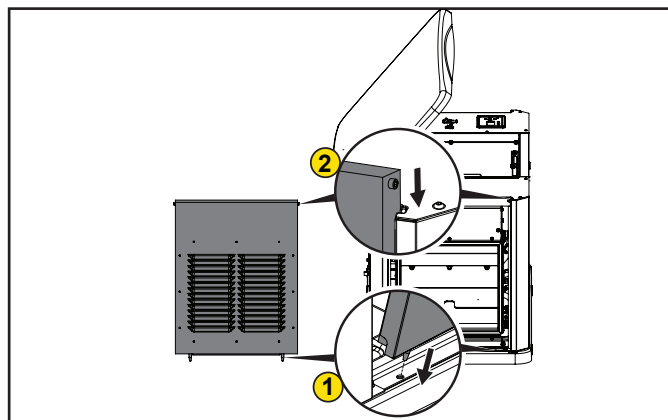

- **Right Panel Removal:** With top cover open, lift up and out each side panel.

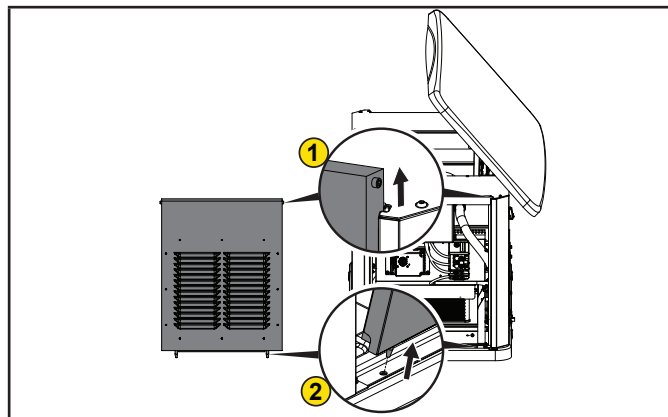

– **Right Panel Replacement:** With top cover open, replace the side panel by locating the panel pins into the base, tilt the cover forward, then slide down with top pins in place. Lower top cover and lock.

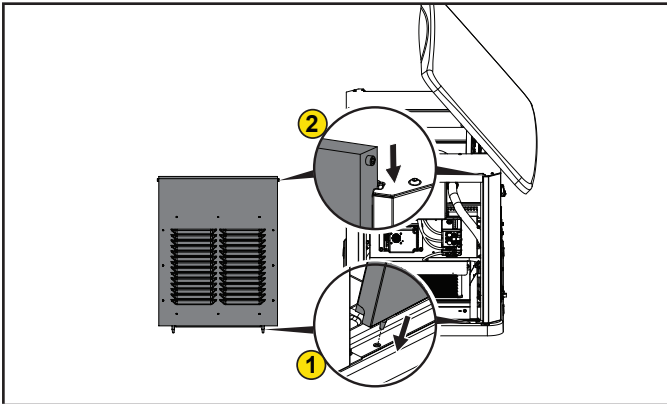

Back Panel

Open the enclosure to gain access to the generator and its components. There is a lock under the top cover front to gain access. Unlock and lift upwards.

– **Back Panel Removal:** With top cover open, from the front, lift up on the back panel, then kick out the bottom edge towards the back once the panel pins clear. From the back, pull the panel down and out from under the top cover.

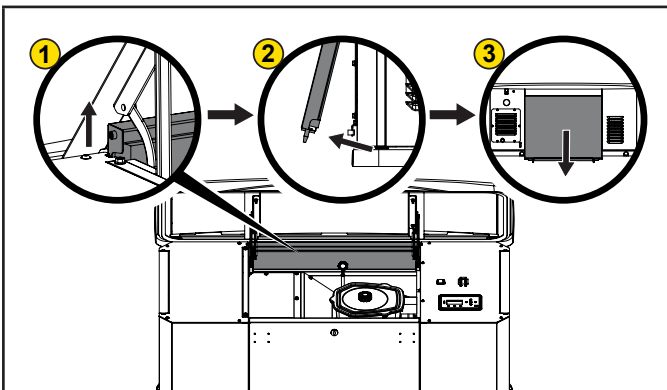

– **Back Panel Replacement:** With top cover open, from the back, lift the back panel under the cover lip, and insert the panels pins in the base. From the front, pull the panel up, then slide the panel down with top pins in place.

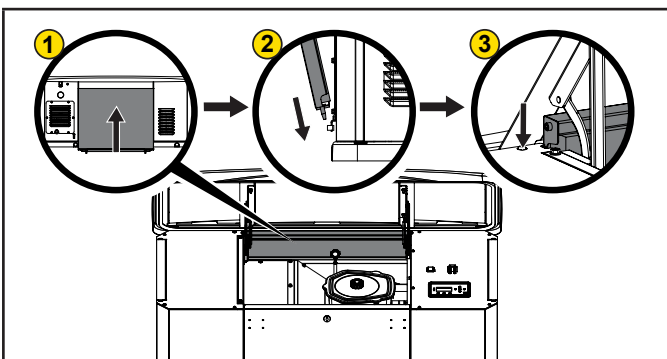

Pre-Start Checklist

To make sure the generator is ready for proper operation, the following items should be checked:

- Both generator ON/OFF switches in the ON position (inside and on the back of the enclosure).
- Fuel Selector Dial is in the correct fuel position
- No fault LED is lit
- Battery is at full charge
- fleX Controller™ is in AUTO mode
- Transfer switch is in the Utility Power position

Turning OFF the Generator

If you need to shut off the generator when it is running, put the fleX Controller™ in the OFF position. This will shut off the engine. With the fleX Controller™ in the OFF position, the generator will not start, even if there is loss of utility power.

MAINTENANCE

Before performing maintenance procedures, review SAFETY section starting on page 8.

Ensure that the ATS and generator ON/OFF switches are in the OFF position before performing any maintenance or cleaning.

Scheduled Maintenance Chart

First 25 Hours of Operation	
Change engine oil and filter - Every 100 hours oil and oil filter change are required	√

Weekly	
Check exterior warning LED	√
Inspect and clean enclosure louvers	√

Monthly	
Check engine oil level	√*
Inspect fuel lines and connections	√
Inspect and clean battery terminals	√

Every 2 Years or 100 Hours of Operation	
Change engine oil and filter when maintenance light comes on	√/***
Inspect and clean engine air cleaner	√/***
Inspect engine spark plug	√
Reset maintenance hour meter every 100 hours	√
Complete inspection of generator, engine tune-up, and valve lash check/adjustment	√/***

* Monthly or 24 hours of continuous operation

** Service sooner if operating in high ambient temperatures or a dusty and dirty environment.

*** Maintenance should be performed by your service dealer.

Spark Plug Specifications

OEM Type Champion RC12YC
 Replacement Type BKR7ES-11 or equivalent
 Gap 0.024-0.031 in. (0.6-0.8 mm)

Oil Filter Specifications

OEM Type 101766
 Replacement Type Fram PH3600 or equivalent

Engine Oil

ENGINE OIL REQUIREMENTS

Use American Petroleum Institute (API) Service Class SN or better. Do not use special additives.

NOTICE

The recommended oil type for typical use is **0W-40 full synthetic oil**. However, using the listed conventional oils shown in the “Recommended Engine Oil Type” chart may be used for typical use.

If running generator in extreme temperatures, refer to the “Recommended Engine Oil Type” chart.

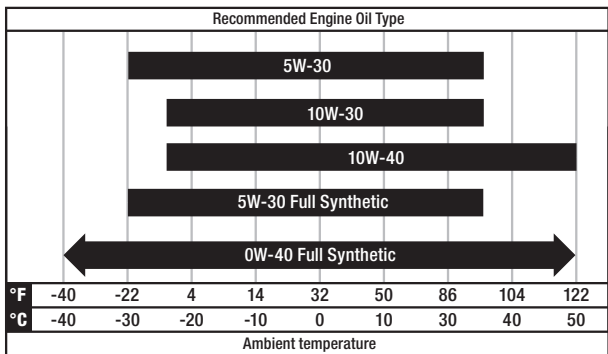

CHECKING THE ENGINE OIL LEVEL

Check the oil level daily when the generator is running for an extended period of time.

1. If the generator is running during a utility outage, turn off all household loads.
2. Put the fleX Controller™ in the OFF position.
3. Remove the dipstick. Wipe it dry with a clean cloth and completely reinsert it into the dipstick tube.

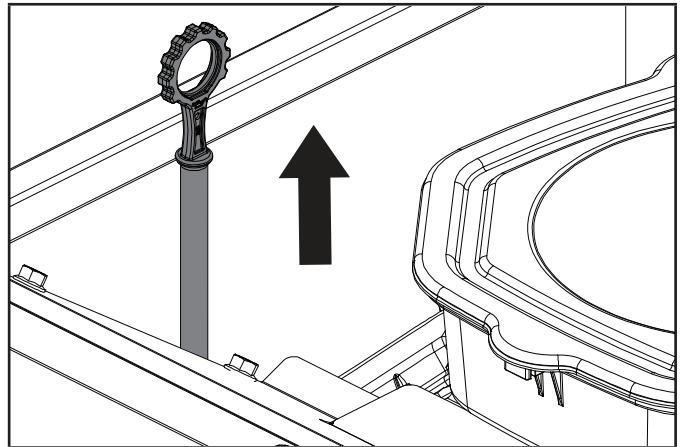

WARNING

DO NOT overfill the engine with engine oil. Damage to the engine may occur.

4. Install the dipstick.
5. Remove the dipstick. The oil level should be at the FULL mark. If necessary, add oil. DO NOT overfill.

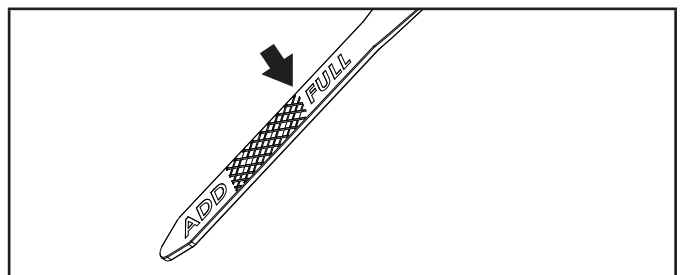

6. Put the fleX Controller™ to the previous position (either Manual/ON, OFF or AUTO for example).

Changing the Engine Oil

WARNING

Always wear protective glasses or goggles and protective clothing when changing hot engine oil.

NOTICE

Always be environmentally responsible. Consult local authorities or reclamations facility for proper disposal of engine oil waste.

1. Press the Manual/ON button on the fleX Controller™ to start and run the HSB.
2. Allow the engine to run until it reaches operating temperature.
3. Put the fleX Controller™ in the OFF position.
4. Remove the fuse from the front of the fleX Controller™. This will disable automatic starting in the event of a power outage.

5. Put the generator ON/OFF switch to the OFF position.
6. Open the top cover and remove the front panel. This front panel is held position with 2 spring loaded pins on the inside. Press inward on each side. Tilt outward from the top and lift up from the base.

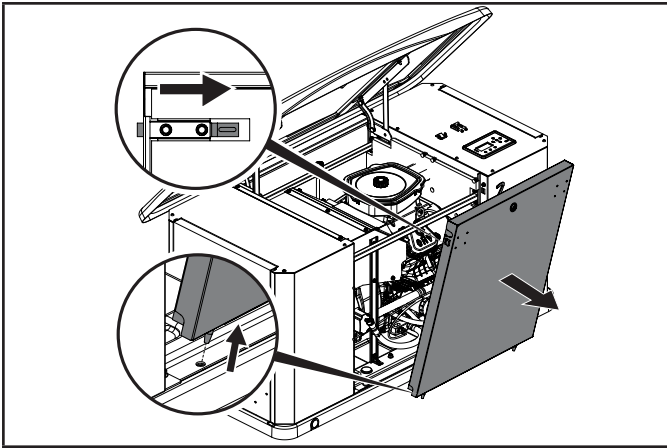

7. Remove oil drain hose (A) from oil hose clamp (B).

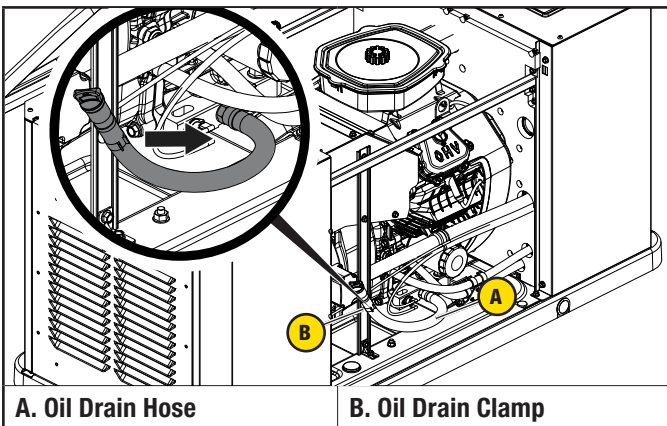

8. Position hose over a suitable drain pan (A). Unscrew oil drain hose cap (B) from oil drain hose (C).

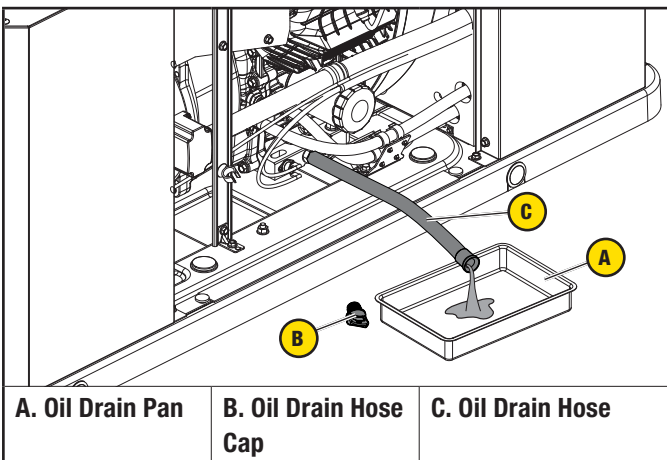

9. Allow crankcase to empty.

10. After the oil is drained, reinstall the oil drain hose cap by screwing it back on snugly, making sure o-ring is in place. Reclip the oil drain hose back on the oil hose clamp that was holding it.

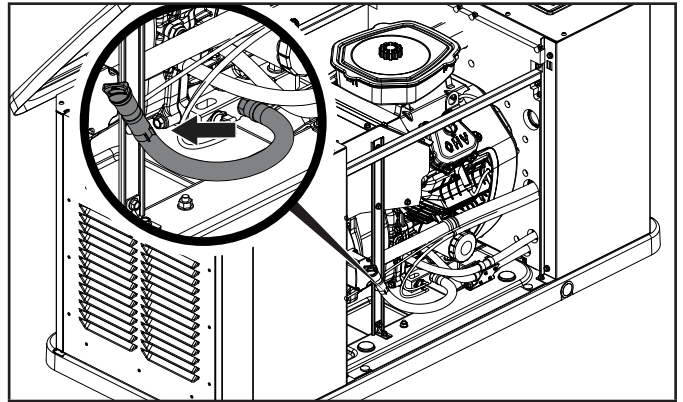

11. Using a funnel, fill the engine with the proper amount of engine oil. DO NOT OVERFILL.

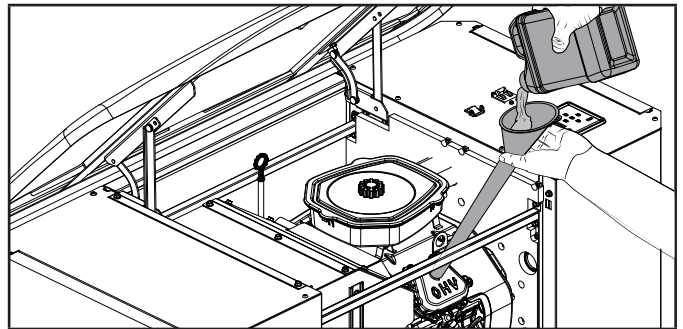

12. Replace the front panel by locating the panel pins into the base, tilt the cover forward, then press inward on each side pin. The pins are located on the top, backside of the front panel.

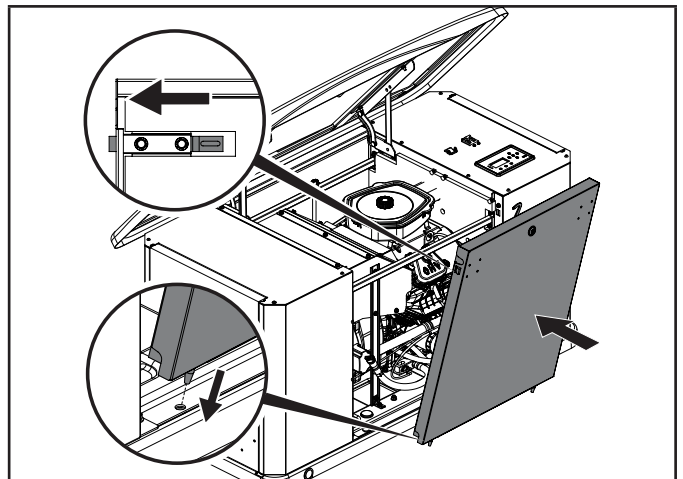

13. Reinstall fuse removed in the earlier step.
14. Turn the generator ON/OFF switch to the ON position.
15. Put the flex Controller™ to the previous position (either MANUAL or AUTO for example).

Inspect and Clean Engine Air Cleaner

1. Press the OFF button on the fleX Controller™.
2. Put the generator ON/OFF switch in the OFF position.
3. Remove the fuse from the front of the fleX Controller™. This will disable automatic starting in the event of a power outage.
4. Open the top cover to gain access to the air filter.
5. Unscrew the air filter screw cap holding the air cleaner cover in place and remove the air cleaner cover. Check the air cleaner gasket is in good shape, if not replace the gasket.
6. Remove the air cleaner paper element to inspect.

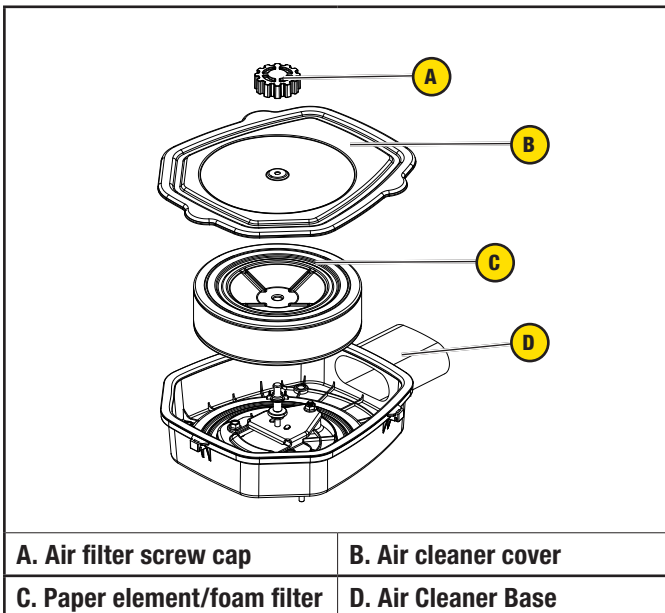

7. Remove the paper element/foam filter (C) and inspect the paper element for any rips or tears. Replace it if damaged.
8. Hold the paper element up to a light. You should be able to see light through the paper element, if not replace the element. Inspect the air cleaner foam element, air cleaner cover and base, remove any dirt or debris.
9. Install paper element plus air cleaner foam element as one piece back in the air cleaner base.
10. Reinstall the air paper element/foam filter.
11. Replace air filter cover and screw the air filter screw cap holding the air cleaner cover on.
12. Put the fleX Controller™ to the previous position (either Manual/ON, OFF or AUTO for example).

Spark Plug

1. Press the OFF button on the fleX Controller™.
2. Remove the fuse from the front of the fleX Controller™. This will disable automatic starting in the event of a power outage.
3. Put the generator ON/OFF switches in the OFF position.
4. Remove the spark plug cable from the spark plug.
5. Clean the area around the spark plug to keep dirt out of the engine and remove the spark plug.
6. Inspect the spark plug electrode and replace the plug if the electrode shows signs of deterioration.
7. Check the gap before installing the spark plug. The spark plug gap should be 0.024 – 0.031 in. (0.6 – 0.8 mm).

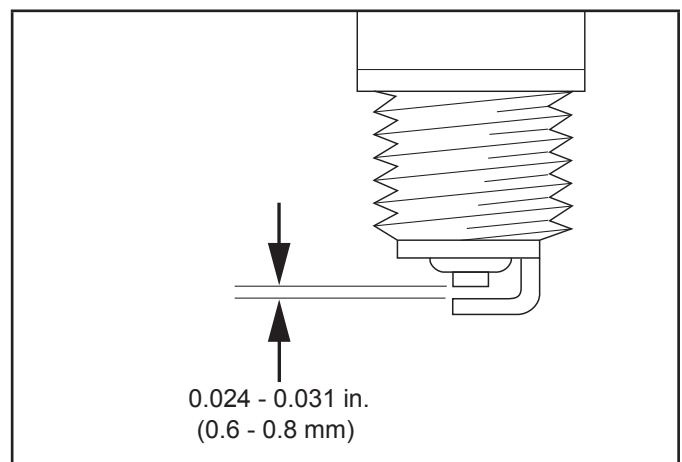

8. Carefully thread the spark plug into the engine and tighten to 20-30 N-m (14.8-22.1 lbf-ft).
9. Re-connect the spark plug cable.
10. Reinstall fuse removed in the earlier step.
11. Put the generator ON/OFF switch to the ON position.
12. Put the fleX Controller™ to the previous position (either Manual/ON, OFF or AUTO for example).

Battery Maintenance

1. Press the OFF button on the fleX Controller™
2. Remove the fuse from the front of the fleX Controller™. This will disable automatic starting in the event of a power outage.
3. Put the generator ON/OFF switches in the OFF position.
4. Inspect the battery cables and terminals for corrosion.
5. Check that the cables are securely fastened to the terminals.
6. Check the ground lug and make sure the connections are tight.
7. Check the fluid level of the battery, unless sealed. If low, top off the level using distilled water only.

Follow all battery instructions provided by the battery manufacturer.

Resetting the Maintenance Hour Meter

The maintenance hour meter counts down 100 hours. Once completed the 100-hour maintenance, refer to below to reset the hour meter.

Refer to the scheduled maintenance chart for specific maintenance.

1. Press up to change reset service to ON.

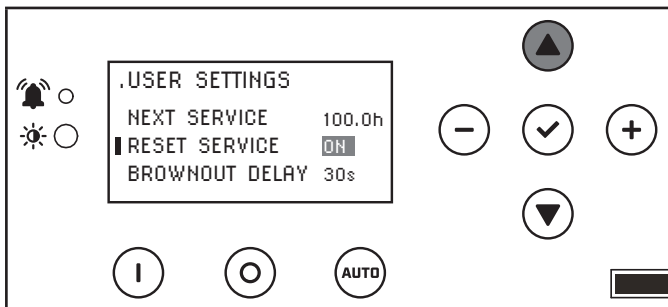

2. Press ok to save the Settings.

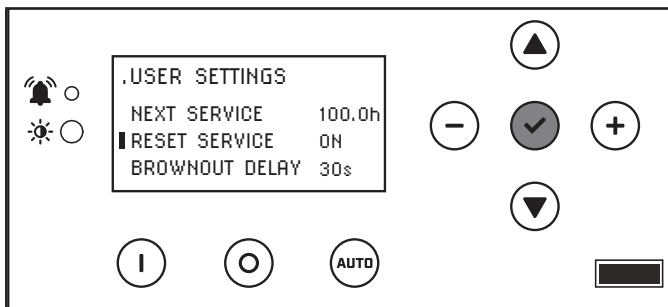

Corrosion Protection

NOTICE

Never use a pressure washer to wash the interior of the generator with water.

Wash the outside of the enclosure using a mild soap and water. Use an automotive-type wax and wax the outside of the enclosure to protect it from the elements. If used in a salt water/coastal area, the enclosure should be washed more frequently to prevent corrosion. Spray light oil on the hinges for the enclosure doors.

Maintenance After Submersion

WARNING

Never try to start or operate the generator if it has been submerged underwater or exposed to a flood.

If the generator has been in conditions where it became submerged underwater, the generator must be inspected and maintenance must be performed before returning the generator to service.

Put the fleX Controller™ in the OFF position. Remove the fuse from the front of the fleX Controller™. This will disable automatic starting in the event of a power outage. Put the generator ON/OFF switches and ATS in the OFF position. Have a authorized Champion Dealer inspect the generator and perform any necessary maintenance.

If the house or building has been exposed to a flood, it should be inspected by a certified electrician for any electrical problems that may occur if the generator is put back into service or if utility power is restored.

TROUBLESHOOTING HSB

Engine will not crank/turn over		
1	HSB set in OFF mode.	Place the flex Controller™ in the AUTO position.
2	Battery not connected or loose, corroded posts or wires	Connect the batteries according to operator's manual, clean and tighten the battery connections
3	Battery(s) not charged or low charge.	Recharge or replace battery(s).
4	Check for active fault code.	Identify fault code, correct and reset.
5	Defective starter solenoid *	
6	Defective starter *	
7	Either generator ON/OFF switch is in the OFF position.	Check both switches are in the ON position (inside and on the back of the enclosure).

Generator will crank/turn over but will not start		
1	Check for active fault code.	Identify fault code, correct and reset.
2	Fuel valve(s) turned off.	Turn on fuel supply.
3	Fuel pressure insufficient*.	Manometer check, confirm fuel pressure to fuel regulator*.
4	Weak battery(s).	Recharge or replace battery(s)
5	Low oil level.	Check for oil leaks. Check the oil level and add oil if necessary.
6	Spark plug wire is disconnected.	Connect spark plug wire.
7	Defective fuel solenoid/regulator. *	

Engine starts, runs rough		
1	Fuel pressure insufficient*.	Manometer check, confirm fuel pressure to fuel regulator*.
2	Wrong fuel.	Check Fuel Selector Dial is in the correct position.
3	Incorrect Fuel Selector Dial position.	Incorrect fuel selected, rotate Fuel Selector Dial to correct fuel.
4	Plugged air cleaner	Clean or replace air cleaner.
5	Generator overloaded*.	Remove one or more loads*.
6	Shorted circuit *	

HSB starts, then suddenly stops		
1	Check for active fault code.	Identify fault code, correct and reset.
2	Fuel supply insufficient*	Manometer check, confirm fuel pressure to fuel regulator*.
3	Low oil pressure shut down.	Check for oil leaks. Check the oil level and add oil if necessary.
4	Generator over loaded.	Turn off standby circuits for house, reset fault, place unit back into AUTO mode. Turn on standby circuits for house. If problem returns contact Champion or Champion service dealer*.
5	Engine high/over temperature shut down.	Check all intake and exhaust ventilation around the HSB, remove all debris. Let HSB sit for 30 minutes to cool down.

No AC output		
1	Circuit breaker in "OFF" position	Turn on breaker.
2	Main circuit breaker in "OFF" position.	Turn on breaker.
3	Transfer switch breaker in "OFF" position.	Turn on breaker.
4	Standby breakers set in "OFF" position.	Turn on breaker.
5	Line circuit tripping breaker because of short circuit *	
6	Line circuit tripping breaker because of overload *	
7	Poor wiring connections*	
8	ATS problems*	

Reset fault code(s)

There is an exterior warning LED located on the back of the enclosure. This should be checked weekly to make sure there are no active fault codes.

Maintenance		
1	The maintenance hour meter counts from 100 hours to 0. You need to reset when the hour meter reaches 0.	Refer to "Resetting the maintenance hour meter" for instructions after performing maintenance.

BATTERY(S) NO OR LOW LEVEL CHARGED, BATTERY(S) DEAD, NEEDS REPLACEMENT, THE EXERCISE TIME MUST BE RESET ONCE THE BATTERY(S) HAVE BEEN DISCONNECTED.

***Contact Champion Power Equipment, Technical Service toll free 1-877-338-0999, tech@championpowerequipment.com or your nearest Champion dealer.*

www.championpowerequipment.com

ADDITIONAL INFORMATION

Surge Protection

⚠ CAUTION

Voltage fluctuation may impair the proper functioning of sensitive electronic equipment.

Electronic devices, including computers and many programmable appliances use components that are designed to operate within a narrow voltage range and may be affected by momentary voltage fluctuations. While there is no way to prevent voltage fluctuations, you can take steps to protect sensitive electronic equipment.

1. Install UL1449, CSA-listed, plug-in surge suppressors on the outlets feeding your sensitive equipment. Surge suppressors come in single or multi-outlet styles. They're designed to protect against virtually all short-duration voltage fluctuations.

Customer Familiarization Summary

It's important to educate the home owner on proper maintenance, operation and service call procedures. A properly educated home owner can reduce unnecessary service trips and phone calls. Ensure that the installation of the HSB and ATS has been correctly performed as outlined by the manufacturer and that it meets all applicable codes.

Test and confirm proper operation of the HSB and ATS system as outlined in the appropriate installation and operator's manuals.

Educate the home owner on the location and operation of;

- Full flow shutoff valve
- Automatic operation of the HSB system
- Battery Charger and LED indicators
- Exterior warning LED on the backside of the HSB
- ATS operation
- Exercise scheduled time of operation
- Scheduled Maintenance
- Fill out and provide the customer a copy of the HSB, ATS model & serial number reference. This information is extremely important for part purchases and service information, these numbers are specific to each HSB and ATS.
- Fill out and provide the customer a copy of the ATS back-up circuits.
- Fill out the Circuit Label inside the ATS.

It's always a good business practice to place business cards in the Operator's and Installation manuals and place dealer stickers on the HSB and ATS for the customer's reference.

HSB, ATS Model & Serial Reference ATS Back-up Circuits

HSB Model Number _____

HSB Serial Number _____

Fuel Type LPG _____ NG _____

ATS Model Number _____

ATS Serial Number _____

ATS circuits powered _____

Date Installed _____

Dealer/Installer _____

Address _____

Phone _____

Cell _____

Purchased from _____

Maintenance and Service Record

Keeping accurate records when any service is performed is important. Records replace guessing when a repair was done or when it should be scheduled. Hour Meter notation as well as the date provides better time period records. To maintain the overall performance throughout the life of the product follow the scheduled maintenance chart contained in your operator's manual or refer to www.championpowerequipment.com. Genuine Champion parts must be used to ensure warranty coverage.

Date _____

Hour Meter _____

Service Performed _____

Record the name, address and phone number of your authorized Champion dealer

10 YEAR LIMITED WARRANTY*

Basic Warranty Provisions

Air-Cooled Home Standby Generators

For a period of 10 years or 2000 hours (whichever occurs first) from successful activation by an Authorized Champion Home Standby Dealer, Champion Power Equipment will, at its option, repair or replace any part(s) which upon examination, inspection and testing by Champion Power Equipment or an Authorized Champion Home Standby Dealer is found to be defective under normal use and service, in accordance with the Warranty Schedule set forth below.

Any equipment that the purchaser/owner claims to be defective must be examined by the nearest Authorized/Certified Champion Home Standby Service Dealer. This warranty applies only to Champion Power Equipment automatic standby generators used in "Standby" applications as Champion has defined Standby. Scheduled Maintenance, as outlined by the generator owner's manual is required. This Scheduled Maintenance should be performed by a knowledgeable, experience operator or an Authorized/Certified Champion Home Standby Service Dealer.

WARRANTY SCHEDULE

Years 1 and 2 – Limited comprehensive coverage on mileage, labor and parts

Years 3 through 10 – Limited comprehensive coverage on parts only

GUIDELINES:

- Warranty begins upon the successful activation of the unit.
- Unit should be Registered and Proof of Purchase and Maintenance must be available.
- Warranty is transferable between ownership of original installation site.
- Warranty only applies to permanently wired and mounted units.
- Any and all warranty repairs and/or concerns must be performed and/or addressed by an Authorized/Certified Champion Home Standby Service Dealer. Repairs or diagnostics performed by individuals other than Authorized/Certified Champion Home Standby Service Dealers not authorized in writing by Champion Power Equipment will not be covered.
- A Champion approved Transfer Switch is highly recommended to be used in conjunction with the generator set. The Champion Transfer Switch is covered under its own, separate warranty listed in the Transfer Switch Instruction Manual and is not covered under this warranty schedule.
- If a Non-Champion approved Transfer Switch is substituted for use and directly causes damage to the generator set, no warranty coverage shall apply.

- Steel enclosures are warranted against rusting for the first year of ownership only. Damage caused after receipt of generator is the responsibility of the owner and is not covered by this warranty. Nicks, scrapes, dents or scratches to the painted enclosure should be repaired promptly by the owner.
- All warranty expense allowances are subject to the conditions defined in Champion Power Equipment "Home Standby" Warranty Policy and Procedures Manual.

THIS WARRANTY SHALL NOT APPLY TO THE FOLLOWING:

- Original installation or start-up costs
- Champion Home Standby generators that utilize non-Champion Power Equipment replacement parts
- Costs of normal maintenance (i.e. tune-ups, associated part(s), adjustments, loose/leaking clamps, installation and start-up)
- Units sold, rated or used for "Prime Power", "Trailer Mounted" or "Rental Unit" applications
- Damage to generator system (including transfer switch) caused by improper installation or costs necessary to correct installation
- Units used for Prime Power in place of existing utility power (where utility power is present) or in place of utility power where utility power service does not normally exist. Prime power includes any application that does not use the utility grid for electric power (example: Solar power)
- Fuel connections other than conventional utility company supplied natural gas systems or conventional LP vapor withdrawal systems
- Any failure caused by contaminated fuels, oils or lack of proper fuels, oils or failure to perform scheduled maintenance and service the air filter
- Steel enclosures that are rusting due to the improper installation, location in a harsh or saltwater environment or scratched where integrity of paint applied is compromised
- Failures due, but not limited, to normal wear and tear, accident, misuse, abuse, negligence or improper installation. As with all mechanical devices, the Champion engines need periodic part(s) service and fluid replacement to perform as designed.
- Failures caused by any external cause or act of God, such as collision, theft, vandalism, riot or wars, nuclear holocaust, fire, freezing, lightning, earthquake, windstorm, hail, volcanic eruption, water or flood, tornado or hurricane
- Damage related to rodent and/or insect infestation
- Covered warranty labor rates are based on normal working hours. Overtime, holiday, or emergency labor costs for repairs outside of normal business hours will be the responsibility of the customer

- Any incidental, consequential or indirect damages caused by defects in materials or workmanship, or any delay in repair or replacement of the defective part(s)
- Failure due to misapplication to provide sufficient cooling air and to regularly exercise the generator under load
- Telephone, cellular phone, facsimile, internet access or other communication expenses
- Living or travel expenses of person(s) performing service, except as specifically included within the terms of a specific unit warranty period
- Expenses related to “customer instruction” or troubleshooting where no manufacturing defect is found
- Rental equipment used while warranty repairs are being performed and/or overnight freight costs for replacement part(s)
- Costs incurred for equipment used for removal and/or reinstallation of generator, (i.e.: cranes, hoists, lifts, etc.)
- Planes, ferries, railroad, buses, helicopters, snowmobiles, snow-cats, off-road vehicles or any other mode of transport deemed abnormal
- Starting batteries, fuses, light bulbs, engine fluids, and spark plugs

Contact Information

Address

Champion Power Equipment, Inc.
 Customer Service
 6370 S Pioneer Way, Unit 101
 Las Vegas, NV 89113 USA
www.championpowerequipment.com

Customer Service and Technical Support

Toll Free: 1-877-338-0999
hsb@cpeauto.com
 Fax no.: 1-562-236-9429

THIS WARRANTY AND THE ATTACHED U.S. EPA WARRANTY ARE IN LIEU OF ALL OTHER WARRANTIES, EXPRESS OR IMPLIED, INCLUDING WARRANTIES OF MERCHANTABILITY OR FITNESS FOR A PARTICULAR PURPOSE.

Any implied warranties which are allowed by law, shall be limited in duration to the terms of the express warranty provided herein. Some states do not allow limitations on how long an implied warranty lasts, so the above limitation may not apply to purchaser/owner.

CHAMPION POWER EQUIPMENT’S ONLY LIABILITY SHALL BE THE REPAIR OR REPLACEMENT OF PART(S) AS STATED ABOVE. IN NO EVENT SHALL CHAMPION POWER EQUIPMENT BE LIABLE FOR ANY INCIDENTAL, OR CONSEQUENTIAL DAMAGES, EVEN IF SUCH DAMAGES ARE A DIRECT RESULT OF CHAMPION POWER EQUIPMENT’S NEGLIGENCE.

Some states do not allow the exclusion or limitation of incidental or consequential damages, so the above limitations may not apply to purchaser/owner. Purchaser/owner agrees to make no claims against Champion Power Equipment based on negligence. This warranty gives purchaser/owner specific legal rights. Purchaser/owner also may have other rights that vary from state to state.

To obtain warranty service or your nearest Champion Home Standby Dealer call Champion Power Equipment Customer Service toll free 1-877-338-0999.

**CHAMPION POWER EQUIPMENT, INC. (CPE)
AND THE UNITED STATES ENVIRONMENTAL PROTECTION AGENCY (U.S. EPA)
EMISSION CONTROL SYSTEM WARRANTY**

Your Champion Power Equipment (CPE) engine complies with U.S. EPA emissions regulations.

YOUR WARRANTY RIGHTS AND OBLIGATIONS:

The US EPA and CPE are pleased to explain the Federal Emission Control Systems Warranty on your 2025 small off-road engine and engine powered equipment. New engines and equipment must be designed, built and equipped, at the time of sale, to meet U.S. EPA regulations for small off-road engines. CPE warrants the emission control system on your small off-road engine and equipment for the period of time listed below, provided there has been no abuse, neglect, unapproved modification, or improper maintenance of your equipment.

Your emission control system may include parts such as the carburetor, fuel-injection system, the ignition system, catalytic converter and fuel lines. Also included may be hoses, belts, connectors and other emission related assemblies. Where a warrantable condition exists, CPE will repair your small off-road engine at no cost to you including diagnosis, parts and labor.

MANUFACTURER'S EMISSION CONTROL SYSTEM WARRANTY COVERAGE:

This emission control system is warranted for two years, subject to provisions set forth below. If, during the warranty period, an emission related part on your engine is defective in materials or workmanship, the part will be repaired or replaced by CPE.

OWNER'S WARRANTY RESPONSIBILITIES:

As the small off-road engine owner, you are responsible for the performance of the required maintenance listed in your Owner's Manual. CPE recommends that you retain all your receipts covering maintenance on your small off-road engine, but CPE cannot deny warranty solely for the lack of receipts or for your failure to ensure the performance of all scheduled maintenance.

As the small off-road engine owner, you should however be aware that CPE may deny you warranty coverage if your small, off-road engine or a part has failed due to abuse, neglect, improper maintenance or unapproved modifications.

You are responsible for presenting your small off-road engine to an Authorized CPE service outlet or alternate service outlet as described in (3)(f.) below, CPE dealer or CPE, Las Vegas, NV. as soon as a problem exists. The warranty repairs should be completed in a reasonable amount of time, not to exceed 30 days.

If you have any questions regarding your warranty rights and responsibilities, you should contact:

Champion Power Equipment, Inc.
Customer Service
6370 S Pioneer Way, Unit 101
Las Vegas, NV 89113
1-877-338-0999
tech@championpowerequipment.com

EMISSION CONTROL SYSTEM WARRANTY

The following are specific provisions relative to your Emission Control System (ECS) Warranty Coverage.

- 1. APPLICABILITY:** This warranty shall apply to 1997 and later model year small off-road engines. The ECS Warranty Period shall begin on the date the new engine or equipment is delivered to its original, end-use purchaser, and shall continue for 24 consecutive months thereafter.
- 2. GENERAL EMISSIONS WARRANTY COVERAGE**

CPE warrants to the original, end-use purchaser of the new engine or equipment and to each subsequent purchaser that the ECS when installed is:

 - 2a. Designed, built and equipped so as to conform to U.S. EPA emissions standards for spark-ignited engines at or below 19 kilowatts.
 - 2b. Free from defects in materials and workmanship that cause the failure of a warranted part to be identical in all material respects to the part as described in the engine manufacturer's application for certification for a period of two years.
- 3. THE WARRANTY ON EMISSION-RELATED PARTS WILL BE INTERPRETED AS FOLLOWS:**
 - 3a. Any warranted part that is not scheduled for replacement as required maintenance in the Operator's Manual shall be warranted for the ECS Warranty Period. If any such part fails during the ECS Warranty Period, it shall be repaired or replaced by CPE according to Subsection "d" below. Any such part repaired or replaced under the ECS Warranty shall be warranted for any remainder of the ECS Warranty Period.
 - 3b. Any warranted, emissions-related part which is scheduled only for regular inspection as specified in the Operator's Manual shall be warranted for the ECS Warranty Period. A statement in such written instructions to the effect of "repair or replace as necessary", shall not reduce the ECS Warranty Period. Any such part repaired or replaced under the ECS Warranty shall be warranted for the remainder of the ECS Warranty Period.
 - 3c. Any warranted, emissions-related part which is scheduled for replacement as required maintenance in the Operator's Manual shall be warranted for the period of time prior to the first scheduled replacement point for that part. If the part fails prior to the first scheduled replacement, the part shall be repaired or replaced by CPE according to Subsection "d" below. Any such emissions-related part repaired or replaced under the ECS Warranty, shall be warranted for the remainder of the ECS Warranty Period prior to the first scheduled replacement point for such emissions-related part.
 - 3d. Repair or replacement of any warranted, emissions-related part under this ECS Warranty shall be performed at no charge to the owner at a CPE Authorized Service Outlet.
 - 3e. The owner shall not be charged for diagnostic labor which leads to the determination that a part covered by the ECS Warranty is in fact defective, provided that such diagnostic work is performed at a CPE Authorized Service Outlet.
 - 3f. CPE shall pay for covered emissions warranty repairs at non-authorized service outlets under the following circumstances:
 - i. The service is required in a population center with a population over 100,000 according to U.S. Census 2000 without a CPE Authorized Service Outlet AND
 - ii. The service is required more than 100 miles from a CPE Authorized Service Outlet. The 100 mile limitation does not apply in the following states: Alaska, Arizona, Colorado, Hawaii, Idaho, Montana, Nebraska, Nevada, New Mexico, Oregon, Texas, Utah and Wyoming.
 - 3g. CPE shall be liable for damages to other original engine components or approved modifications proximately caused by a failure under warranty of an emission-related part covered by the ECS Warranty.
 - 3h. Throughout the ECS Warranty Period, CPE shall maintain a supply of warranted emission-related parts sufficient to meet the expected demand for such emission-related parts.
 - 3i. Any CPE Authorized and approved emission-related replacement part may be used in the performance of any ECS Warranty maintenance or repair and will be provided without charge to the owner. Such use shall not reduce CPE's warranty obligation.
 - 3j. Unapproved add-on or modified parts may not be used to modify or repair a CPE engine. Such use voids this ECS Warranty and shall be sufficient grounds for disallowing an ECS Warranty claim. CPE shall not be liable hereunder for failures of any warranted parts of a CPE engine caused by the use of such an unapproved add-on or modified part.

EMISSION-RELATED PARTS INCLUDE THE FOLLOWING: (using those portions of the list applicable to the engine)

Systems covered by this warranty	Parts Description
Fuel Metering System	Fuel regulator, Carburetor and internal parts
Air Induction System	Air cleaner, Intake manifold
Ignition System	Spark plug and parts, Magneto ignition system
Exhaust System	Exhaust manifold, catalytic converter
Miscellaneous Parts	Tubing, Fittings, Seals, Gaskets, and Clamps associated with these listed systems.
Evaporative Emissions	Fuel Tank, Fuel Cap, Fuel Lines (for liquid fuel and fuel vapors), Fuel Line Fittings, Clamps, Pressure Relief Valves, Control Valves, Control Solenoids, Electronic Controls, Vacuum Control Diaphragms, Control Cables, Control Linkages, Purge Valves, Gaskets, Liquid/Vapor Separator, Carbon Canister, Canister Mounting Brackets, Carburetor Purge Port Connector

TO OBTAIN WARRANTY SERVICE:

You must take your CPE engine or the product on which it is installed, along with your warranty registration card or other proof of original purchase date, at your expense, to any Champion Power Equipment dealer who is authorized by Champion Power Equipment, Inc. to sell and service that CPE product during his normal business hours. Alternate service locations defined in Section (3)(f.) above must be approved by CPE prior to service. Claims for repair or adjustment found to be caused solely by defects in material or workmanship will not be denied because the engine was not properly maintained and used.

If you have any questions regarding your warranty rights and responsibilities, or to obtain warranty service, please write or call Customer Service at Champion Power Equipment, Inc.

Champion Power Equipment, Inc.
6370 S Pioneer Way, Unit 101
Las Vegas, NV 89113
1-877-338-0999
Attn.: Customer Service
tech@championpowerequipment.com