

FUEL TANK OVERVIEW

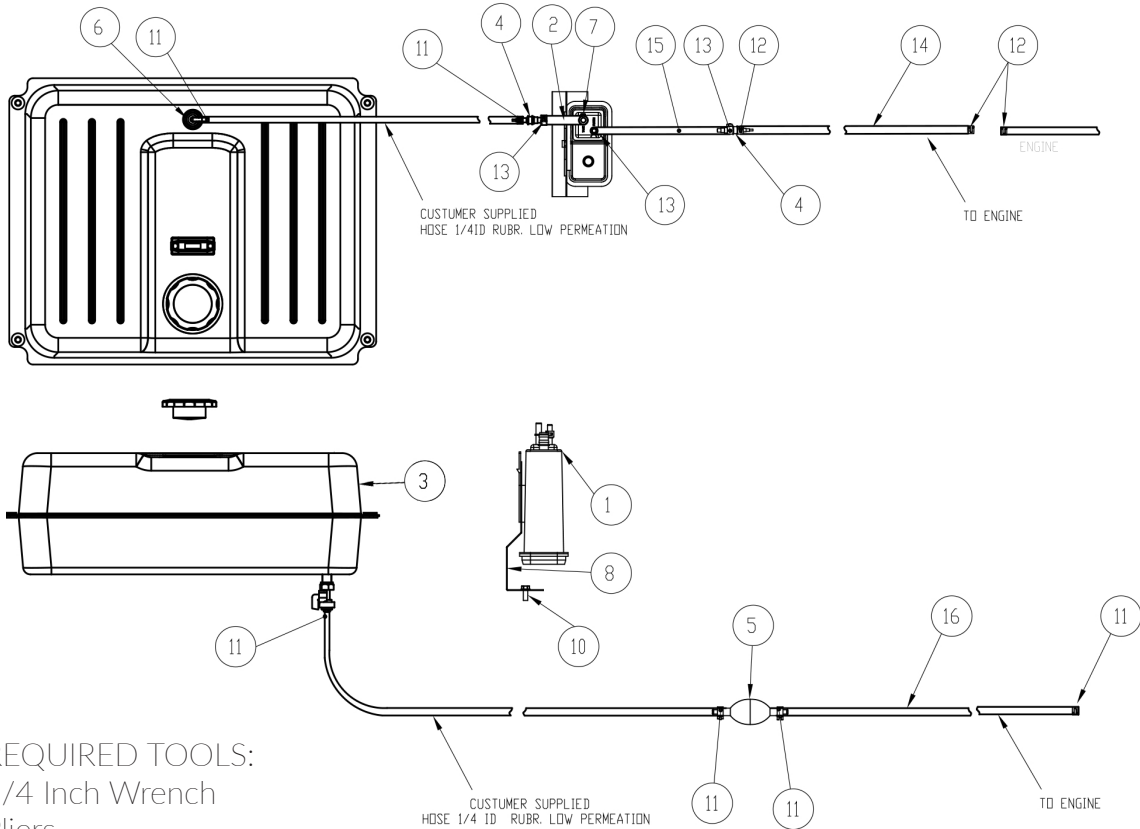

REQUIRED TOOLS:
 3/4 Inch Wrench
 Pliers

COMPONENT LIST

REF. #	PART #	DESCRIPTION	QTY.
1	80900-000	15 Gal Carbon Canister	1
2*	55505-026	Hose .375 ID Rubber 3 In	1
3	64024-014	15 Gal Fuel Tank W/ Fuel Cap	1
4*	98590-003	Hose Reducer 1/8-5/16 x 1/4-7/16	2
5	62391-000	Fuel Primer Bulb	1
6*	80903-002	Slosh Valve With Grommet	1
7*	81018-008	Hose Clamp .875-.25	1
8	81900-001	Carbon Canister Bracket	1
10*	62173-001	Self Tap Screws 5/16-18 x .75	2
11*	62999-001	Hose Clamp .5 OD Red	6
12*	62999-005	Hose Clamp .41 OD Green	3
13*	62999-004	Hose Clamp .69 OD Black	3
14	40077-001	3/16" Fuel Line Cut 34.00"	1
15	40079-001	5/16" Fuel line Cut 8.00"	1
16	40078-031	Hose 1/4" Diam Rubber 36" Long	1

*Located in parts bag 19022-411

STEP 1

- Open hardware bag and separate components.

FASTENERS & MISC. COMPONENTS (not shown in actual size)

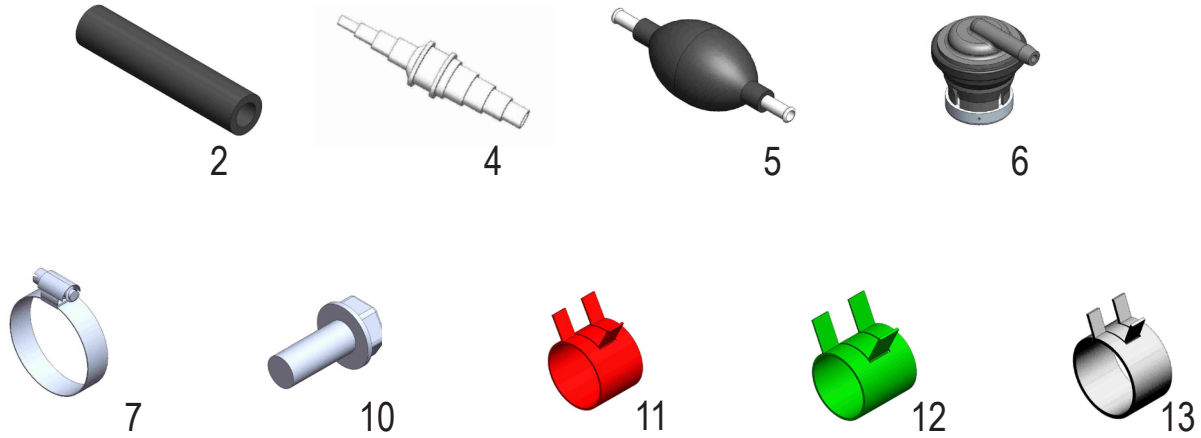

HARDWARE & FASTENER LIST			
REF #	PART #	DESCRIPTION	QTY
2*	55505-026	Hose .375 ID Rubber 3 In	1
4*	98590-003	Hose Reducer 1/8-5/16 x 1/4-7/16	2
5**	62391-000	Fuel Primer Bulb	1
6*	80903-002	Slosh Valve With Grommet	1
7*	81018-008	Hose Clamp .875-.25	1
10*	62173-001	Self Tap Screw 5/16-18 x .75	2
11*	62999-001	Hose Clamp .5 OD Red	6
12*	62999-005	Hose Clamp .41 OD Green	3
13*	62999-004	Hose Clamp .69 OD Black	3

**Fuel primer bulb ships loose

STEP 2

- Attach the carbon canister bracket (ref. 8) using the two self tapping screws (ref. 10)
- Slide the carbon canister (ref. 1) up into the carbon canister bracket and then slide it down until it is locked in place.

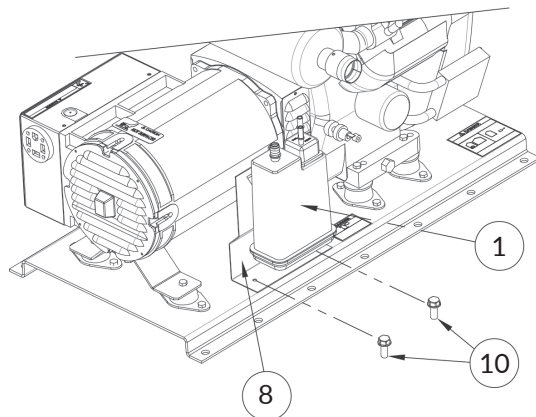

STEP 3

- Mount fuel tank (ref. 3) in a suitable location to ensure proper flow of fuel. The fuel tank must be mounted to a bracket to allow access to the shut-off valve. Bolt holes are located on the flanges on the side. Use 3/8-16 x any length bolts. The length will vary depending on the mounting structure.

Note: When mounting the fuel tank below the level of the engine, an additional fuel pump may be required for a lift of 3 feet or more from the bottom of the fuel tank to pump on the engine. Hose lengths may have to be adjusted for your application.

- Install sash valve (ref. 6) into the top of the fuel tank.
- Install fuel cap on top of the fuel tank.

WARNING: FIRE DANGER

When selecting a location for mounting the fuel tank, ensure it is not located closely to hot engine or generator components. Gasoline and its fumes are VERY explosive when proper precautions are not taken.

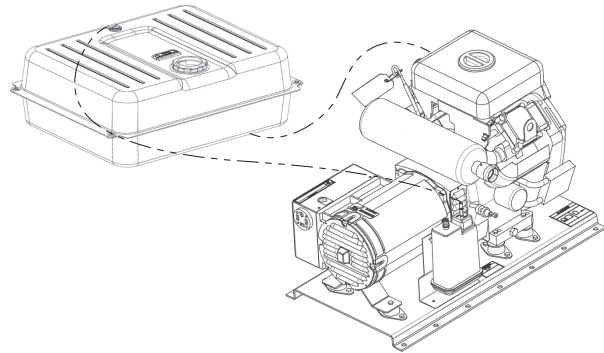

STEP 4

- Route customer supplied 1/4" fuel line from fuel tank to engine and attach the fuel line to the primer bulb (ref. 5) with red hose clamps (ref. 11). Attach 1/4" fuel hose (ref. 16) to the other side of the primer bulb with a red hose clamp and route to the fuel filter on the engine (see ref. A in step 5).
- Attach 1/4" hose (ref. 16) to the fuel filter on the engine using red hose clamp (ref. 11).

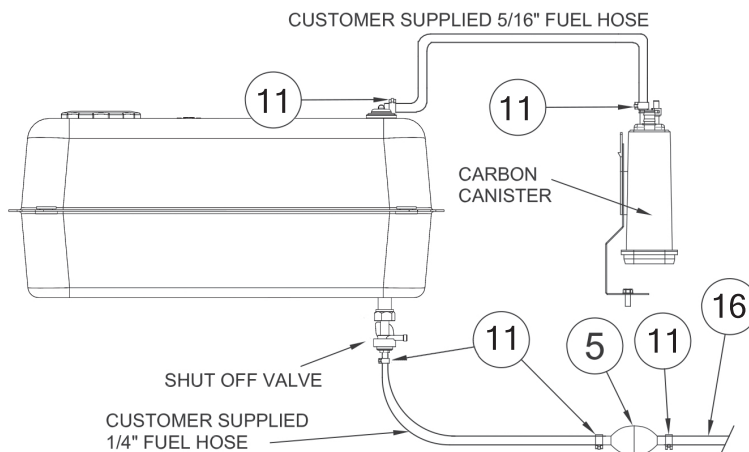

STEP 5

- Fuel filter (ref. A) is where you connect the fuel line (ref. 16 from step 4).

NOTE: Each installation may vary. Your fuel line length depends on your installation requirements.

DANGER

Do not allow fuel lines to lay directly on or near 'HOT' surfaces. This may cause a fire.

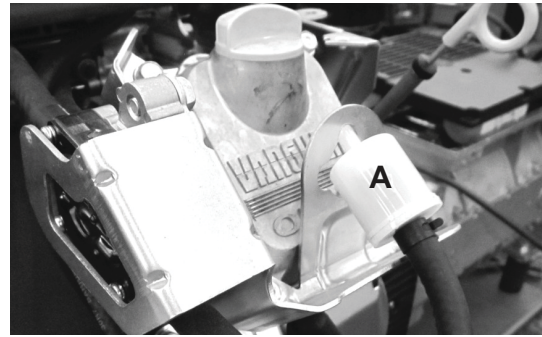

STEP 6

- Locate the small plastic bag that came with the Briggs & Stratton engine operator's manual. You will use the connector (ref. B) in step 7. You can discard the other part as it is not needed for this application.

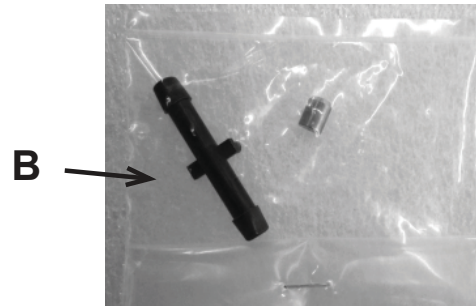

STEP 7

- Slide black hose clamps (ref. 13) onto 5/16" fuel hose (ref. 15) by compressing them with a pliers. Push hose (ref. 15) onto carbon canister nipple marked PURGE and move the clamp into position at the end of the hose.
- Twist and push hose reducer (ref. 4) onto the hose (ref. 15) and move the clamp into position at the end of the hose. NOTE: You can use a small amount of vegetable oil on the hoses to ease their connection.
- Twist and push hose reducer (ref. 4) onto the 3/16" hose (ref. 14) and secure with green clamp (ref. 12). Insert the connector (ref. B from step 6) to the end of the 3/16" hose (ref. 14) and secure with a green hose clamp (ref. 12). This will connect to the engine.

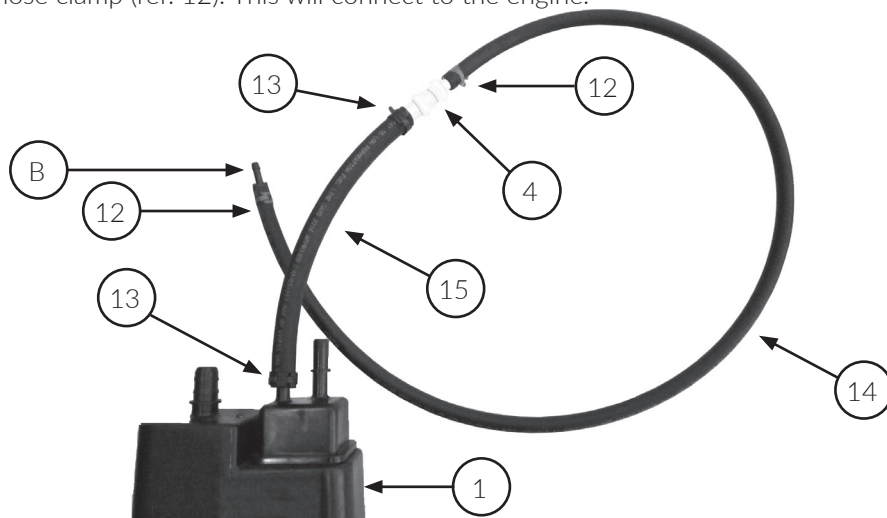

STEP 8

- Locate the hose (ref. C) on the left side of the engine that has a plastic ball inserted in the end of it. Use a small screw driver to remove the ball.
- Slide green hose clamp (ref. 12) over the hose (ref. C) using a plier.
- Using hose assembly from step 7, insert connector (ref. B) into hose (ref. C).
- Slide green hose clamp down to the end of the hose clamping it to the connector (ref. B).

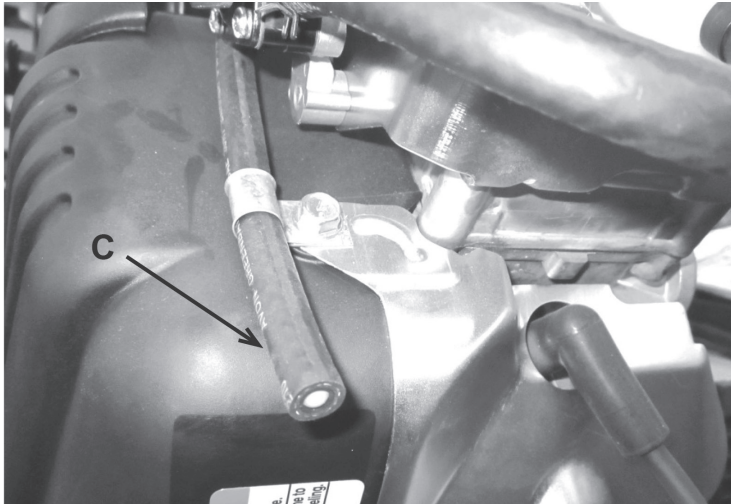

STEP 9

- Attach customer supplied 5/16" fuel hose to the slosh valve (ref. 6). See step 4 for illustration.
- Route customer supplied 5/16" fuel hose (ref. D) to the carbon canister (ref. 1) and connect to the nipple marked TANK using black hose clamp (ref. 13).

Note: The Mechanical Fuel Pump on Carbureted Engines can manage up to 12" of lift. The Supply Pump on EFI Engines can manage up to 36" of Lift. (Wet) For fuel supply runs of greater distance, a 12V electric fuel pump can be added. Electric fuel pump pressure not to exceed 1.5 PSI and recommend wiring 12V+ supply to the accessory wire on the key switch so that the fuel pump will only power with the key on. Electric Fuel Pump should be plumbed after the primer bulb.

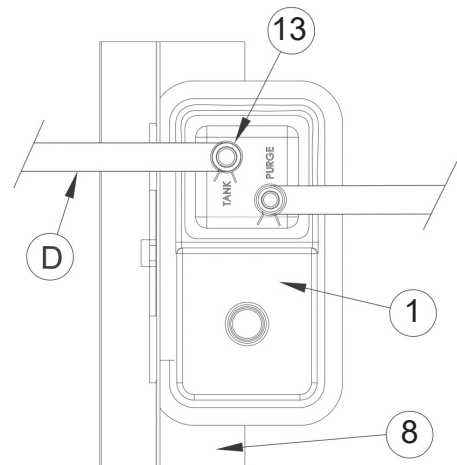

CALIFORNIA PROPOSITION 65

WARNING:



This product contains crude oil, gasoline, diesel fuel and other petroleum products, Antifreeze to which can expose you to chemicals including toluene and benzene, Ethylene glycol (ingested) which are known to the State of California to cause cancer, birth defects or other reproductive harm and developmental issues. For more information go to www.P65Warning.ca.gov.

Service
507-357-6831
service@wincogen.com